

## PROLINE® XE POWER DIRECT VENT COMMERCIAL-GRADE RESIDENTIAL

The ProLine® XE Power Direct Vent water heaters have been engineered to maximize efficiency and deliver a greater energy factor (EF).

### POWER DIRECT VENT DESIGN

- Combined horizontal and vertical vent runs up to 180 equivalent feet with 4" diameter venting (ABS, PVC, CPVC and polypropylene)
- Two-pipe sealed combustion system uses outside air, eliminating problems caused by insufficient indoor ventilation
- Reduced NOx emissions comply with air quality management district regulations

### ENERGY STAR® QUALIFIED

- All models (except GPDx 75L) meet the ENERGY STAR® EF requirement and may also qualify for local utility and rebate programs
- 2-inch thick, "Environmentally-Friendly" foam insulation reduces the amount of heat loss and contributes to overall energy efficiency
- Built-in heat traps on the water inlet and outlet reduce the amount of heat lost through piping

### DYNACLEAN™ DIFFUSER DIP TUBE

- Helps reduce lime and sediment buildup and maximizes hot water output. Made from long-lasting PEX cross-linked polymer.

### HOT-SURFACE IGNITOR

- More robust and reliable than standing pilot, and reduces energy consumption.

### BLUE DIAMOND® GLASS COATING

- Provides superior corrosion resistance compared to the industry-standard glasslining.

### USER-FRIENDLY

- State-of-the-art electronic gas control provides more precise temperature control
- LED control light displays operation status and diagnostics information

### ENHANCED-FLOW BRASS DRAIN VALVE

- Our residential water heaters have a solid brass, tamper resistant, enhanced-flow, ball type, drain valve.
- Uses a standard female hose fitting that allows for fast and easy draining during maintenance.
- Designed for easy operation, this valve includes an integral screwdriver slot that features a ¼ turn (open/close) radius, which not only permits full straight-through water flow but also a quick and positive shut off.

### CSA CERTIFIED AND ASME RATED T&P RELIEF VALVE

### DESIGN-CERTIFIED BY CSA INTERNATIONAL

- Certified at 150 psi working pressure.
- Certified to ANSI Z21.10.1-CSA 4.1 or ANSI Z21.10.3-CSA 4.3 standards governing storage tank-type water heaters

### AVAILABLE IN NATURAL GAS AND PROPANE

### 6-YEAR LIMITED TANK AND PARTS WARRANTY



(EXCEPT GPDx 75L)



Model Number	Series	Gallon Capacity	Input BTU/h	Energy Factor	First Hour Rating Gallon	Recovery @ 90°F Rise Gallon Per Hour	Dimensions in Inches								Approx. Shipping Weight (lb)
							A	B	C	D	E	F	G	H	
GPDL 40	200	40	40,000	0.71	71	45.2	58-1/4	49-5/8	22	29-7/8	11	13-1/4	42-1/2	15-1/4	174
GPDT 50	200	50	45,000	0.70	93	50.3	67-1/2	58-3/4	22	29-7/8	11	13-1/4	51-3/4	15-1/4	192
GPDX 50L	200	50	62,000**	0.71	115	72.6	69	60-1/4	22	29-7/8	11	13-1/4	52-3/4	15-1/4	200
† GPDX 75L	210	75	76,000	N/A	N/A	82.4	70-5/8	61-1/2	26	33-7/8	11	13-1/4	53	15-1/4	277

\*\*Propane (LP) model has input of 58,000 BTU/hr.

For side connect models, add 'L' to model number, e.g. GPDT 50L. Side connections available on GPDL and GPDT models.

Side connections are standard on GPDX models.

Natural gas models cited are series 200/210. Propane models are series 201/211

All models rated for installation at altitudes up to 10,100 ft.

† GPDX 75L is not ENERGY STAR® Qualified.

Vent Length			
Model Number	Maximum Vent Length Eq. Ft.		
	Ø2"	Ø3"	Ø4"
GPDL 40	50'	125'	180'
GPDT50	50'	125'	180'
GPDX 50L	N/A	50'	125'
GPDX 75L	N/A	50'	125'

Optional Vent Kits	
Description	Part Number
2" Vent Kit- Coupling, sound suppressor	330828-000
3" Vent Kit- Coupling, sound suppressor	330851-000
2" Concentric Vent Kit	9008586005
3" Concentric Vent Kit	9006328005
Hi Ambient Kit	9009024015

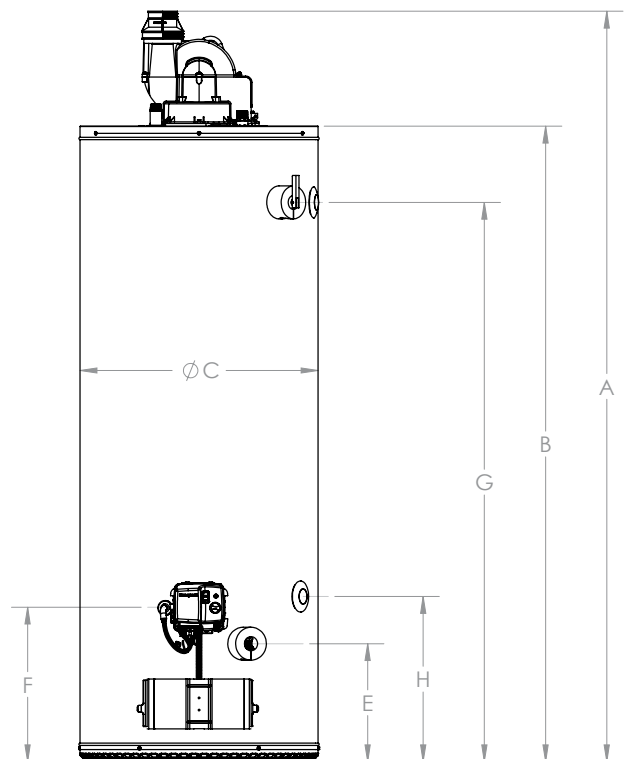
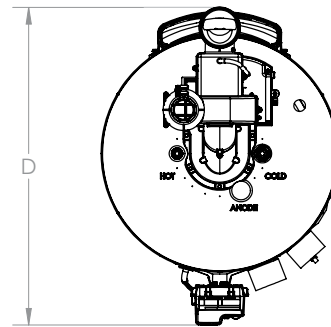

For technical information call 800-527-1953. A. O. Smith Corporation reserves the right to make product changes or improvements without prior notice.