

MASTER-FIT® ULTRA-LOW NOx COMMERCIAL GAS WATER HEATERS

FAN ASSISTED COMBUSTION

- The blower is built into the low NOx burner assembly
- Complies with California SCAQMD Rule 1146.2 and other air quality management districts with similar NOx emission requirements of 14 ng/l or 20 ppm

AIR-FLAPPER

- A stainless steel air flapper is used inside the premix system to replace externally mounted flue damper to minimize the standby heat loss and to minimize the overall heater height

METAL VENTING

- Rated Category I Appliance. Uses standard double wall type "B" vent
- Can be commonly vented with other Category I appliances
- Vent connects directly to the vent connector outlet
- An excellent choice for retrofit and upgrade installations
- When common venting multiple BTL water heaters into a common vent system, follow the common vent tables in the current edition of the National Fuel Gas Code book for Category 1, Fan assisted heaters.

WATER CONNECTIONS

- For ease of installation, all BTL's feature water connections on the top, front, and back
- "The Eliminator" inlet water connection eliminates harmful scale buildup, extending the life of the product
- The front inlet connection must be used for the Eliminator benefits

GLASSLINED TANK

- Permaglas® Ultracoat is the proprietary ceramic coating developed by A. O. Smith's ceramic engineers specifically for the heater
- Glassing is applied after the complete tank has been assembled to give a seamless barrier against hot water corrosion

INSTALLED COST SAVINGS

- The BTL uses a smaller vent diameter than a natural draft water heater which saves on installation cost

FULLY AUTOMATIC DIGITAL CONTROLS WITH SAFETY SHUTOFF

- Accurate, dependable control system
- Manual reset gas shutoff device for added safety

FOAM INSULATION

- Saves fuel, helps reduce standby heat loss

JACKET

- Heavy gauge steel finished with a baked enamel finish over a bonderized undercoat

EASY CLEANING

- Handhole cleanout allows access for easy cleaning

FULLY TESTED FOR SAFETY AND PERFORMANCE

- Design certified by the Underwriters Laboratory for 180°F hot water service
- Meets rigid requirements of the National Sanitation Foundation when equipped with optional leg kit
- Certified for use on combustible flooring

INTERMITTENT IGNITION DEVICE

- Eliminates standing pilot
- Provides flame failure response in less than one second
- Spark ignitor and power ON/OFF switch

EASY TO INSTALL

- Completely factory-assembled
- Only gas, water, vent and electric connections need to be made. Provided with drain valve

ANODES

- CoreGuard™ long-life, stainless steel core anode rods

PLUG KITS

- Pipe nipples and caps are included to plug unused water connections

LP MODEL

- Liquid Propane version now available with BTL-199

APPROVAL RATINGS AND CERTIFICATION

- All models meet ANSI Z21.10.3 - CSA 4.3 standards and the thermal efficiency and standby loss requirements of the U.S. Department of Energy and current edition of ASHRAE/IES 90.1

3-YEAR LIMITED TANK / 1-YEAR LIMITED PARTS WARRANTY

- For complete warranty information, consult written warranty or go to howater.com



**MODELS
BTL-120 THRU BTL-400(A)
SERIES 200**



ON SELECT MODELS



ROUGH IN DIMENSIONS: MASTER-FIT BTL-120 through BTL-400(A)

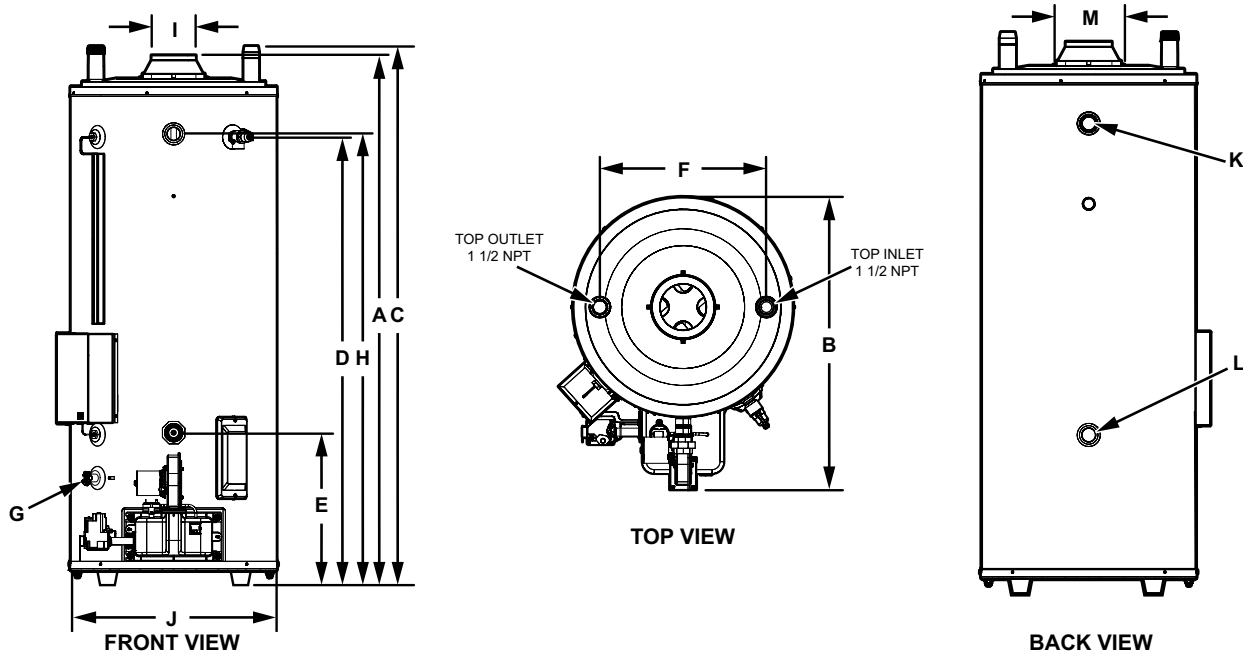

DIMENSIONS

Model Dimension	BTL-120, 154, 180, 198		BTL-199, 250(A), 275(A)		BTL-310(A), 366(A), 400(A)	
	Inches	cm	Inches	cm	Inches	cm
A	63-3/4	161.93	71-3/4	182.25	71-3/4	182.25
B	37	93.98	37	93.98	37	93.98
C	65	165.1	73	185.42	73	185.42
D	52-3/4	133.99	60-3/4	154.31	60-3/4	154.31
E	20-3/4	52.71	20-1/2	52.07	20-1/2	52.07
F	21	53.34	21	53.34	21	53.34
G	3/4 NPT					
H	53	134.62	61	154.94	61	154.94
I	6	15.24	6	15.24	6	15.24
J	27-3/4	70.49	27-3/4	70.49	27-3/4	70.49
K	1-1/2 NPT					
L	1-1/2 NPT					
M	N/A	N/A	8	20.3	8	20.3
Approx. Shipping Weight	BTL-120, 154, 180, 198		BTL-199, 250(A), 275(A)		BTL-310(A), 366(A), 400(A)	
	lbs.	kg	lbs.	kg	lbs.	kg
Standard	605	174	665	301	740	335
ASME	N/A	N/A	715	324	790	358

Dimensions and specifications subject to change without notice in accordance with our policy of continuous product improvement
 All models rated at 80% thermal efficiency
 "A" after the model number designates ASME construction.



Ultra-Low NOx Commercial Gas Water Heaters

OTHER MASTER-FIT® FEATURES

- Integral automatic gas shutoff system prevents excessive water temperature
- CSA Certified and ASME Rated T&P Relief valve are factory-installed
- Maximum working pressure is 160 PSI standard
- Adjustable thermostat with a 120-180°F range

NSF LEG KIT

- Meets NSF Standard 5 with optional leg kit -Part #100211940
- Leg kit increases height by 4"

Model Number	Capacity		Input Btuh	Input kW
BTL-120	Gallon	81	120,000	35
	Litres	307		
BTL-154	Gallon	81	154,000	45
	Litres	307		
BTL-180	Gallon	81	180,000	53
	Litres	307		
BTL-198	Gallon	81	199,000	58
	Litres	307		
BTL-199*	Gallon	100	199,000	58
	Litres	378		
BTL-250(A)	Gallon	100	250,000	73
	Litres	378		
BTL-275(A)	Gallon	100	275,000	81
	Litres	378		
BTL-310(A)	Gallon	86	310,000	91
	Litres	325		
BTL-366(A)	Gallon	86	366,000	107
	Litres	325		
BTL-400(A)	Gallon	86	390,000	114
	Litres	325		

"A" after the model number designates ASME construction

* 199 model now available in LP version.

GAS AND ELECTRICAL CHARACTERISTICS

Model	Gas Type	Gas Supply Pressure		Voltz/Hz	Amperes
		Minimum	Maximum		
120 Thru 275(A)	Natural	3.5" W.C. (0.87 kPA)	14" W.C. (3.48 kPA)	120/60	<5
310 (A) Thru 400 (A)	Natural	4.5" W.C. (1.12 kPA)	14" W.C. (3.48 kPA)	120/60	<5

Model	Clearance to Combustibles			
	"A" Right Side	"B" Left Side	"C" Back	"D" Ceiling
ALL	0"	0"	0"	12"
	0 cm	0 cm	0 cm	30.5 cm



Ultra-Low NOx Commercial Gas Water Heaters

RECOVERY CAPACITIES

Model Number	U.S. Gallons/ Hr. and Litres/ Hr. at Temperature Rise Indicated																
	F°	36	40	50	54	60	70	72	80	90	100	108	110	120	126	130	140
	C°	20	22	28	30	33	39	40	44	50	56	60	61	67	70	72	78
BTL-120	GPH	320	288	230	213	192	165	160	144	128	115	107	105	96	91	89	82
	LPH	1212	1091	872	808	727	623	606	545	485	436	404	397	364	346	336	312
BTL-154	GPH	411	370	296	274	246	211	205	185	164	148	137	134	123	117	114	106
	LPH	1555	1399	1120	1037	933	800	777	700	622	560	518	509	466	444	431	400
BTL-180	GPH	480	432	346	320	288	247	240	216	192	173	160	157	144	137	133	123
	LPH	1818	1636	1309	1212	1091	935	909	818	727	654	606	595	545	519	503	467
BTL-198	GPH	531	478	382	354	319	273	265	239	212	191	177	174	159	152	147	137
	LPH	2009	1808	1447	1340	1206	1033	1005	904	804	723	670	658	603	574	556	517
BTL-199	GPH	531	478	382	354	319	273	265	239	212	191	177	174	159	152	147	137
	LPH	2009	1808	1447	1340	1206	1033	1005	904	804	723	670	658	603	574	556	517
BTL-250(A)	GPH	667	600	480	445	400	343	333	300	267	240	222	218	200	191	185	171
	LPH	2524	2272	1818	1683	1515	1298	1262	1136	1010	909	841	826	757	721	699	649
BTL-275(A)	GPH	734	660	528	489	440	377	367	330	293	264	245	240	220	210	203	189
	LPH	2777	2499	1999	1851	1666	1428	1388	1250	1111	1000	926	909	833	793	769	714
BTL-310(A)	GPH	827	744	595	551	496	425	413	372	331	298	276	271	248	236	229	213
	LPH	3130	2817	2254	2087	1878	1610	1565	1409	1252	1127	1043	1024	939	894	867	805
BTL-366(A)	GPH	976	879	703	651	586	502	488	439	391	352	325	320	293	279	270	251
	LPH	3696	3326	2661	2464	2217	1901	1848	1663	1478	1330	1232	1209	1109	1056	1023	950
BTL-400(A)	GPH	1040	936	749	694	624	535	520	468	416	375	347	340	312	297	288	268
	LPH	3938	3544	2835	2625	2363	2025	1969	1772	1575	1418	1313	1289	1181	1125	1091	1013

For ASME models add (A) to the end of the model number example BTL-400A
Recoveries based on 80% thermal efficiency

SPECIFICATION

Water Heater(s) shall be Model BTL_____ as manufactured by A. O. Smith, or equal. Water heater(s) shall be of glasslined design, gas fired, equipped to burn natural gas and design certified by the Underwriters Laboratory under Volume III tests for commercial heaters for delivery of 180°F water and meets the thermal efficiency and standby loss requirements of the U.S. Department of Energy and Current Edition of ASHRAE/IES 90.1. Heaters shall have an input rating of _____ BTU and a recovery rating of _____ (GPH) at a temperature rise of 100°F with a storage capacity of _____ gallons. Heaters shall be equipped with 1-1/2" water inlet and outlet openings, a 2-3/4" x 3-3/4" boiler-type handhole cleanout and shall have a maximum working pressure of 160 PSI. Water heater(s) shall be equipped with an integrated control system consisting of a 180°F adjustable thermostat with upper and lower sensing bulbs, which average the water temperatures at the top and bottom of the tank for maximum water temperature control. Heater(s) shall be provided with a manual reset gas shutoff device, anodes for cathodic protection and IID system. CSA Certified and ASME Rated T&P Relief Valve shall be furnished and installed by the factory. The heater shall be insulated with foam insulation or equal. The outer jacket shall have a baked enamel finish over a bonderized undercoating. All internal surfaces of the heater(s) exposed to water shall be glasslined with an alkaline borosilicate composition that has been fused-to-steel by firing at a temperature range of 1400° to 1600°F. Heater tank shall have a 3 year limited warranty against corrosion or sediment buildup as outlined in the written warranty. Fully illustrated instruction manual to be included.

For Technical Information call 800-527-1953. A.O.Smith Corporation reserves the right to make product changes or improvements without prior notice.