

# 77W SERIES

## Bronze APOLLOXPRESS® Ball Valve

Press x Press, Maximum operating pressure, 250 psi.  
 Temperature range, 0°F-250°F,  
 MSS SP-110 compliant.  
 Directive 2002/95/CE (RoHS) compliant.



### FEATURES

- Full-port
- Adjustable stem packing
- Fast, easy, economical installation
- Leak Before Press® feature
- Blow-out proof stem
- Corrosion resistant materials
- 100% factory tested

- Silicon free
- Ridgid® Press tool compatible

### VARIATIONS AVAILABLE:

77W-140 Series (316 SS Ball & Stem)

### OPTIONS AVAILABLE: (More information in Section J)

(SUFFIX)	OPTION	SIZES
-01	Standard Configuration	All
-04-	2.25" Stem Extension	1/2" to 2"
-07-	Tee Handle	1/2" to 2"
-10-	S.S. Handle and Nut	1/2" to 2"
-11-	Therma-Seal™ Insulating Tee Handle	3/8" to 2.5"
-18-	Plain Grip	1/2" to 2"
-92-	Balancing Stop	1/2" to 2"
-94-	2.25" Stem Ext. & Balancing Stop	1/2" to 2"
-HC-	Hose Cap & Chain	1/2" to 1"

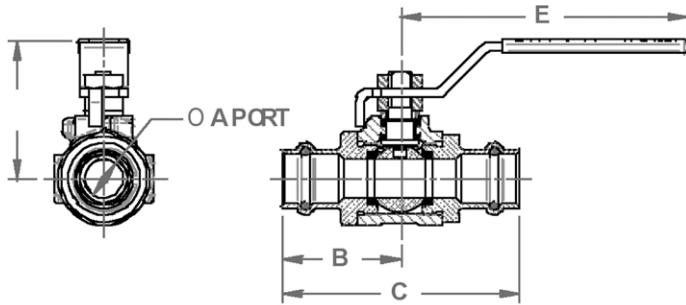

### STANDARD MATERIAL LIST

	PART	MATERIAL
1	Body	B584-C84400
2	Seat	Multifill PTFE
3	Ball	ASTM B16
4	Stem packing	Multifill PTFE
5	Nut	Zinc plated steel
6	Stem	ASTM B16
7	Retainer	ASTM B16
8	Handle	Plated steel/insulated polyvinyl
9	Gland	Brass, ASTM B16, UNS# C36000
10	O-ring	EPDM

PRODUCT NUMBER	SIZE	A	B	C	D	E	WT.
77W-103-01	1/2"	0.50	1.54	3.08	1.50	3.74	0.61
77W-104-01	3/4"	0.75	1.78	3.55	2.01	4.78	1.09
77W-105-01	1"	1.00	1.93	3.86	2.20	4.78	1.77
77W-106-01	1.25"	1.25	2.44	4.87	3.13	7.04	4.27
77W-107-01	1.5"	1.50	2.91	5.81	3.10	7.04	4.63
77W-108-01	2"	2.00	3.74	7.47	3.48	7.04	8.21

FOR PRESSURE/TEMPERATURE RATINGS, REFER TO PAGE M-10, GRAPH NO. 4



# FLOW DATA

## For Apollo® Ball Valves

The listed Cv "factors" are derived from actual flow testing, in the Apollo® Ball Valve Division, Conbraco Industries, Inc., Pageland, South Carolina. These tests were completed using standard "off the shelf" valves with no special preparation and utilizing standard schedule 40 pipe. It should be understood that these factors are for the valve only and also include the connection configuration. The flow testing is done utilizing water as a fluid media and is a direct statement of the gallons of water flowed per minute with a 1 psig pressure differential across the valve/connection unit. Line pressure is not a factor. Because the Cv is a factor, the formula can be used to estimate flow of most media for valve sizing.

### FLOW OF LIQUID

$$Q = C_v \sqrt{\frac{\Delta P}{SpGr}}$$

$$\text{or } \Delta P = \frac{(Q)^2 (SpGr)}{(C_v)^2}$$

#### Where:

Q = flow in US gpm  
 ΔP = pressure drop (psig)  
 SpGr = specific gravity at flowing temperature  
 Cv = valve constant

### FLOW OF GAS

$$Q = 1360 C_v \sqrt{\frac{(\Delta P) (P_2)}{(SpGr) (T)}}$$

$$\text{or } \Delta P = \frac{5.4 \times 10^{-7} (SpGr) (T) (Q)^2}{(C_v)^2 (P_2)}$$

#### Where:

Q = flow in SCFH  
 ΔP = pressure drop (psig)  
 SpGr = specific gravity (based on air = 1.0)  
 P<sub>2</sub> = outlet pressure-psia (psig + 14.7)  
 T = (temp. °F + 460)  
 Cv = valve constant

### Cv FACTORS FOR APOLLO VALVES

SIZE (IN.)	1/4	3/8	1/2	3/4	1	1.25	1.5	2	2.5	3	4	6	8	10	12
<b>VALVE</b>															
32-100/200 Series	5.1	6.6	8	24	30	45	55	95	--	--	--	--	--	--	--
64-100/200 Series	6	7	19	34	50	104	268	309	629	1018	1622	--	--	--	--
64W Series	--	--	--	--	--	--	--	--	629	1018	1622	--	--	--	--
70B-140 Series	8.4	7.2	15	30	43	48	84	108	190	370	670	--	--	--	--
70-100/200 Series	8.4	7.2	15	30	43	48	84	108	190	370	670	--	--	--	--
70-300/400 Series	--	--	15	30	43	48	84	108	--	--	--	--	--	--	--
70-600 Series	2.3	4.5	5.4	12	14	21	34	47	--	--	--	--	--	--	--
70-800 Series	8.4	7.2	15	30	43	48	84	--	--	--	--	--	--	--	--
71AR Series	--	--	--	30	43	48	84	108	190	370	--	--	--	--	--
71-100/200 Series	--	--	--	30	43	48	84	108	190	370	--	--	--	--	--
72-100/900 Series	--	--	26	48	65	125	170	216	--	--	--	--	--	--	--
73A-100 Series	8.4	7.2	15	30	43	48	84	108	--	--	--	--	--	--	--
73-300/400 Series	--	--	26	48	65	125	170	216	--	--	--	--	--	--	--
74-100 Series	8.4	7.2	15	30	43	48	84	108	190	370	670	--	--	--	--
75-100 Series	8.4	7.2	15	30	43	48	84	108	190	370	670	--	--	--	--
76AR Series	8.4	7.2	15	30	43	48	84	108	190	370	670	--	--	--	--
76F-100 Series	8.1	15	15	51	68	125	177	389	--	--	--	--	--	--	--
76-100 Series	8.4	7.2	15	30	43	48	84	108	190	370	--	--	--	--	--
76-300/400 Series	--	--	26	48	65	125	170	216	--	--	--	--	--	--	--
76-600 Series	2.3	4.5	5.4	12	14	21	34	47	--	--	--	--	--	--	--
7K-100 Series	--	--	15	51	68	125	177	389	503	--	--	--	--	--	--
77AR Series	8.1	15	15	51	68	125	177	389	--	--	--	--	--	--	--
77C-100/200 Series	4.5	7.2	16	36	68	125	177	389	503	--	--	--	--	--	--
77D-140 Series	4.5	7.2	16	36	68	125	177	389	--	--	--	--	--	--	--
77D-640 Series	--	--	--	11	24	35	--	--	--	--	--	--	--	--	--
77G-UL Series	4.5	7.2	16	36	68	125	177	389	503	--	--	--	--	--	--
77W Series	--	--	16	36	68	125	177	389	--	--	--	--	--	--	--
77X Series	--	--	16	36	68	--	--	--	--	--	--	--	--	--	--
77-100/200 Series	8.1	15	15	51	68	125	177	389	503	--	--	--	--	--	--
79 Series	8.5	8.5	9.8	32	44	66	148	218	440	390	--	--	--	--	--

continued on next page



# FLOW DATA

## For Apollo® Ball Valves

### Cv FACTORS FOR APOLLO VALVES (continued from page M-3)

SIZE (IN.)	1/4	3/8	1/2	3/4	1	1.25	1.5	2	2.5	3	4	6	8	10	12
<b>VALVE</b>															
80/81 Series	8.4	7.2	15	30	43	48	84	108	190	370	--	--	--	--	--
82-100/200 Series	8.1	14	26	51	68	120	170	376	510	996	1893	--	--	--	--
83A/83B Series	8.1	14	26	51	68	120	170	376	--	--	--	--	--	--	--
83R-100/200 Series	--	--	--	--	--	--	170	376	--	996	1893	--	--	--	--
86A/86B Series	8.1	14	26	51	68	120	170	376	--	--	--	--	--	--	--
86R-100/200 Series	--	--	--	--	--	--	170	376	--	996	1893	--	--	--	--
87A-100 Series	--	--	--	--	--	--	86	104	234	375	673	1099	1902	3890	--
87A-200 Series	--	--	15	19	75	--	195	410	545	1021	2016	4837	9250	15170	22390
87A-700 Series	--	--	--	--	--	--	86	104	234	375	673	1099	1902	3890	--
87A-900 Series	--	--	15	19	75	--	195	410	545	1021	2016	4837	9250	15170	22390
87B-100 Series	--	--	--	--	--	--	--	--	--	375	673	1099	1902	3890	--
88A-100 Series	--	--	--	--	--	--	86	104	234	375	673	1099	1902	3890	--
88A-200 Series	--	--	15	19	75	--	195	410	545	1021	2016	4837	9250	15170	22390
88A-700 Series	--	--	--	--	--	--	86	104	234	375	673	1099	1902	3890	--
88A-900 Series	--	--	15	19	75	--	195	410	545	1021	2016	4837	9250	15170	22390
88B-100 Series	--	--	--	--	--	--	--	--	--	375	673	1099	1902	3890	--
89-100 Series	8.4	7.2	15	30	43	48	84	108	190	370	--	--	--	--	--
9A-100 Series	8.3	6.7	5.7	10	16	25	40	62	--	--	--	--	--	--	--
91-100 Series	8.3	6.7	5.7	10	16	25	40	62	--	--	--	--	--	--	--
92-100 Series	8.3	6.7	5.7	10	16	25	40	62	--	--	--	--	--	--	--
93-100 Series	8.3	6.7	5.7	10	16	25	40	62	--	--	--	--	--	--	--
94A-100/200 Series	6	7	19	34	50	104	268	309	629	1018	1622	--	--	--	--
95-100/200 Series	--	--	15	51	68	--	--	--	--	--	--	--	--	--	--
95A-300/400 Series	--	--	19	34	50	--	--	--	--	--	--	--	--	--	--
96-100 Series	8.3	6.7	5.7	10	16	25	40	62	--	--	--	--	--	--	--
399-100 Series	8.4	7.2	15	30	43	48	84	108	190	370	--	--	--	--	--
489-100 Series	8.4	7.2	15	30	43	48	84	108	190	370	--	--	--	--	--

# PRESSURE TEMPERATURE RATINGS

## 400# Bronze (GRAPH 3)

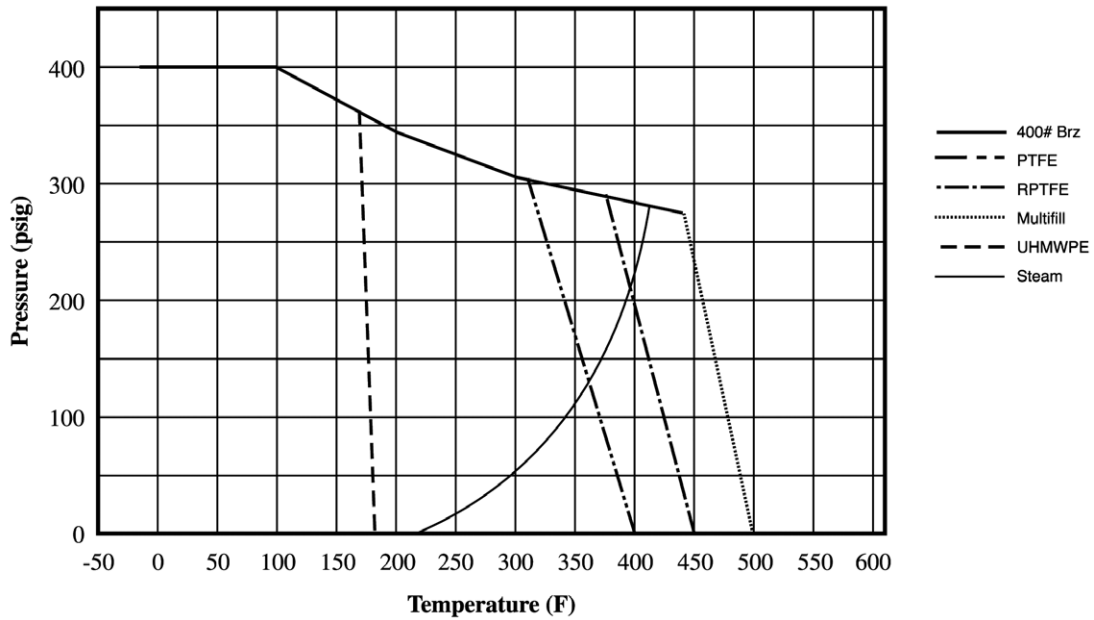

## 600# Bronze (GRAPH 4)

