

# 70-200 SERIES

## Solder End Bronze Ball Valve

Solder End, 600 CWP (psig), Cold Non-Shock. 150 psig Saturated Steam. (See referenced P/T charts)  
 Vacuum Service to 29 inches Hg.  
 MSS SP-110 compliant.



### FEATURES

- Two-piece body
- Blow-out-proof stem design
- Reinforced seats
- Adjustable packing gland

### VARIATIONS AVAILABLE:

70-240 Series (316 SS Ball & Stem)

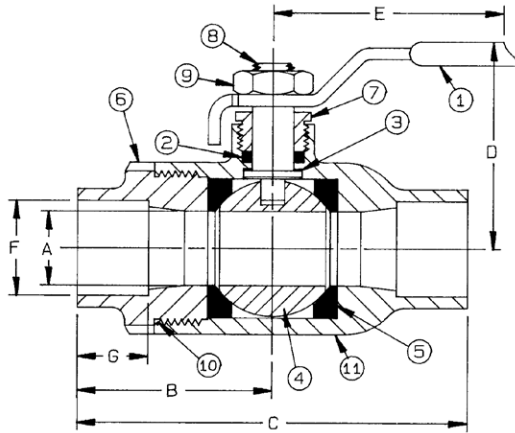

### STANDARD MATERIAL LIST

PART	MATERIAL
1	Steel, zinc plated w/vinyl
2	MPTFE
3	RPTFE
4	B16, chrome plated
5	RPTFE (3/8" to 3"); TFM (4")
6	B16 (3/8" to 1") B584-C84400 (1.25" to 4")
7	B16
8	B16
9	Steel, zinc plated
10	PTFE
11	B584-C84400

### OPTIONS AVAILABLE: (More information in Section J)

(SUFFIX)	OPTION	SIZES
-01	Standard Configuration	All
-02-	Stem Grounded	3/8" to 4"
-04-	2.25" CS Stem Extension	3/8" to 3"
-05-	Plain Ball	3/8" to 3"
-07-	Steel Tee Handle	3/8" to 2"
-08-	90° Reversed Stem	3/8" to 3"
-10-	SS Lever & Nut	3/8" to 3"
-11-	Therma-Seal™ Insulating Tee Handle	3/8" to 2"
-14-	Side Vented Ball (Uni-Directional)	3/8" to 4"
-15-	Wheel Handle, Steel	3/8" to 2"
-16-	Chain Lever - Vertical	3/4" to 2"
-24-	Graphite Packing	3/8" to 3"
-27-	SS Latch-Lock Lever & Nut	3/8" to 3"
-32-	SS Tee Handle & Nut	3/8" to 2"
-35-	PTFE Trim	3/8" to 3"
-39-	SS Hi-Rise Locking Wheel Handle, SS Nut	3/8" to 2"
-45-	Less Lever & Nut	3/8" to 3"
-46-	Latch Lock Lever - Lock in Closed Position Only	3/8" to 3"
-47-	SS Oval Latch-Lock Handle & Nut	3/8" to 2"
-48-	SS Oval Handle (No Latch) & Nut	3/8" to 2"
-49-	Assembled Dry	3/8" to 4"
-50-	2.25" CS Locking Stem Extension	3/8" to 3"
-56-	Multifill Seats & Packing	3/8" to 3"
-57-	Oxygen Cleaned	3/8" to 4"
-58-	Chain Lever - Horizontal	3/4" to 2"
-60-	Static Grounded Ball & Stem	3/8" to 3"
-63-	NPT x Solder/Socket Weld	3/8" to 4"
-92-	Balancing Stop	3/8" to 3"
-94	2.25" Stem Extension, Balancing Stop	3/8" to 3"
-HC-	Hose Cap & Drain	1/2" to 1"

PRODUCT NUMBER	SIZE	A	B	C	D	E	F	G	WT.
70-202-01	3/8"	0.37	1.28	2.56	1.75	3.87	.505	0.37	0.63
70-203-01	1/2"	0.50	1.43	2.87	1.75	3.87	.630	0.50	0.71
70-204-01	3/4"	0.68	1.93	3.87	2.12	4.87	.880	0.75	1.44
70-205-01	1"	0.87	2.25	4.50	2.25	4.87	1.130	0.90	1.91
70-206-01	1.25"	1.00	2.31	4.62	2.62	5.50	1.380	0.96	2.95
70-207-01	1.5"	1.25	2.62	5.25	3.06	8.00	1.630	1.09	3.99
70-208-01	2"	1.50	3.18	6.37	3.25	8.00	2.130	1.34	5.71
70-209-01A	2.5"	2.00	3.74	7.51	3.72	8.00	2.630	1.48	15.53
70-200-01	3"	2.50	4.12	8.25	4.12	8.00	3.130	1.67	16.74
70-20A-01	4"	3.12	5.65	10.26	5.22	9.94	4.130	2.16	27.93

The 70-200 is designed to be soft soldered into lines without disassembly. This allows a tested valve to be installed without disturbing the seats and seals in any way. Soldering temperature not to exceed 500°F.

**FOR PRESSURE/TEMPERATURE RATINGS,  
REFER TO PAGE M-10, GRAPH NO. 4**

# FLOW DATA

## For Apollo® Ball Valves

The listed Cv "factors" are derived from actual flow testing, in the Apollo® Ball Valve Division, Conbraco Industries, Inc., Pageland, South Carolina. These tests were completed using standard "off the shelf" valves with no special preparation and utilizing standard schedule 40 pipe. It should be understood that these factors are for the valve only and also include the connection configuration. The flow testing is done utilizing water as a fluid media and is a direct statement of the gallons of water flowed per minute with a 1 psig pressure differential across the valve/connection unit. Line pressure is not a factor. Because the Cv is a factor, the formula can be used to estimate flow of most media for valve sizing.

### FLOW OF LIQUID

$$Q = C_v \sqrt{\frac{\Delta P}{\text{SpGr}}}$$

$$\text{or } \Delta P = \frac{(Q)^2 (\text{SpGr})}{(C_v)^2}$$

**Where:**

Q = flow in US gpm  
 ΔP = pressure drop (psig)  
 SpGr = specific gravity at flowing temperature  
 Cv = valve constant

### FLOW OF GAS

$$Q = 1360 C_v \sqrt{\frac{(\Delta P) (P_2)}{(\text{SpGr}) (T)}}$$

$$\text{or } \Delta P = \frac{5.4 \times 10^{-7} (\text{SpGr}) (T) (Q)^2}{(C_v)^2 (P_2)}$$

**Where:**

Q = flow in SCFH  
 ΔP = pressure drop (psig)  
 SpGr = specific gravity (based on air = 1.0)  
 P<sub>2</sub> = outlet pressure-psia (psig + 14.7)  
 T = (temp. °F + 460)  
 Cv = valve constant

### Cv FACTORS FOR APOLLO VALVES

SIZE (IN.)	1/4	3/8	1/2	3/4	1	1.25	1.5	2	2.5	3	4	6	8	10	12
<b>VALVE</b>															
32-100/200 Series	5.1	6.6	8	24	30	45	55	95	--	--	--	--	--	--	--
64-100/200 Series	6	7	19	34	50	104	268	309	629	1018	1622	--	--	--	--
64W Series	--	--	--	--	--	--	--	--	629	1018	1622	--	--	--	--
70B-140 Series	8.4	7.2	15	30	43	48	84	108	190	370	670	--	--	--	--
70-100/200 Series	8.4	7.2	15	30	43	48	84	108	190	370	670	--	--	--	--
70-300/400 Series	--	--	15	30	43	48	84	108	--	--	--	--	--	--	--
70-600 Series	2.3	4.5	5.4	12	14	21	34	47	--	--	--	--	--	--	--
70-800 Series	8.4	7.2	15	30	43	48	84	--	--	--	--	--	--	--	--
71AR Series	--	--	--	30	43	48	84	108	190	370	--	--	--	--	--
71-100/200 Series	--	--	--	30	43	48	84	108	190	370	--	--	--	--	--
72-100/900 Series	--	--	26	48	65	125	170	216	--	--	--	--	--	--	--
73A-100 Series	8.4	7.2	15	30	43	48	84	108	--	--	--	--	--	--	--
73-300/400 Series	--	--	26	48	65	125	170	216	--	--	--	--	--	--	--
74-100 Series	8.4	7.2	15	30	43	48	84	108	190	370	670	--	--	--	--
75-100 Series	8.4	7.2	15	30	43	48	84	108	190	370	670	--	--	--	--
76AR Series	8.4	7.2	15	30	43	48	84	108	190	370	670	--	--	--	--
76F-100 Series	8.1	15	15	51	68	125	177	389	--	--	--	--	--	--	--
76-100 Series	8.4	7.2	15	30	43	48	84	108	190	370	--	--	--	--	--
76-300/400 Series	--	--	26	48	65	125	170	216	--	--	--	--	--	--	--
76-600 Series	2.3	4.5	5.4	12	14	21	34	47	--	--	--	--	--	--	--
7K-100 Series	--	--	15	51	68	125	177	389	503	--	--	--	--	--	--
77AR Series	8.1	15	15	51	68	125	177	389	--	--	--	--	--	--	--
77C-100/200 Series	4.5	7.2	16	36	68	125	177	389	503	--	--	--	--	--	--
77D-140 Series	4.5	7.2	16	36	68	125	177	389	--	--	--	--	--	--	--
77D-640 Series	--	--	--	11	24	35	--	--	--	--	--	--	--	--	--
77G-UL Series	4.5	7.2	16	36	68	125	177	389	503	--	--	--	--	--	--
77W Series	--	--	16	36	68	125	177	389	--	--	--	--	--	--	--
77X Series	--	--	16	36	68	--	--	--	--	--	--	--	--	--	--
77-100/200 Series	8.1	15	15	51	68	125	177	389	503	--	--	--	--	--	--
79 Series	8.5	8.5	9.8	32	44	66	148	218	440	390	--	--	--	--	--

continued on next page



# FLOW DATA

## For Apollo® Ball Valves

### Cv FACTORS FOR APOLLO VALVES (continued from page M-3)

SIZE (IN.)	1/4	3/8	1/2	3/4	1	1.25	1.5	2	2.5	3	4	6	8	10	12
<b>VALVE</b>															
80/81 Series	8.4	7.2	15	30	43	48	84	108	190	370	--	--	--	--	--
82-100/200 Series	8.1	14	26	51	68	120	170	376	510	996	1893	--	--	--	--
83A/83B Series	8.1	14	26	51	68	120	170	376	--	--	--	--	--	--	--
83R-100/200 Series	--	--	--	--	--	--	170	376	--	996	1893	--	--	--	--
86A/86B Series	8.1	14	26	51	68	120	170	376	--	--	--	--	--	--	--
86R-100/200 Series	--	--	--	--	--	--	170	376	--	996	1893	--	--	--	--
87A-100 Series	--	--	--	--	--	--	86	104	234	375	673	1099	1902	3890	--
87A-200 Series	--	--	15	19	75	--	195	410	545	1021	2016	4837	9250	15170	22390
87A-700 Series	--	--	--	--	--	--	86	104	234	375	673	1099	1902	3890	--
87A-900 Series	--	--	15	19	75	--	195	410	545	1021	2016	4837	9250	15170	22390
87B-100 Series	--	--	--	--	--	--	--	--	--	375	673	1099	1902	3890	--
88A-100 Series	--	--	--	--	--	--	86	104	234	375	673	1099	1902	3890	--
88A-200 Series	--	--	15	19	75	--	195	410	545	1021	2016	4837	9250	15170	22390
88A-700 Series	--	--	--	--	--	--	86	104	234	375	673	1099	1902	3890	--
88A-900 Series	--	--	15	19	75	--	195	410	545	1021	2016	4837	9250	15170	22390
88B-100 Series	--	--	--	--	--	--	--	--	--	375	673	1099	1902	3890	--
89-100 Series	8.4	7.2	15	30	43	48	84	108	190	370	--	--	--	--	--
9A-100 Series	8.3	6.7	5.7	10	16	25	40	62	--	--	--	--	--	--	--
91-100 Series	8.3	6.7	5.7	10	16	25	40	62	--	--	--	--	--	--	--
92-100 Series	8.3	6.7	5.7	10	16	25	40	62	--	--	--	--	--	--	--
93-100 Series	8.3	6.7	5.7	10	16	25	40	62	--	--	--	--	--	--	--
94A-100/200 Series	6	7	19	34	50	104	268	309	629	1018	1622	--	--	--	--
95-100/200 Series	--	--	15	51	68	--	--	--	--	--	--	--	--	--	--
95A-300/400 Series	--	--	19	34	50	--	--	--	--	--	--	--	--	--	--
96-100 Series	8.3	6.7	5.7	10	16	25	40	62	--	--	--	--	--	--	--
399-100 Series	8.4	7.2	15	30	43	48	84	108	190	370	--	--	--	--	--
489-100 Series	8.4	7.2	15	30	43	48	84	108	190	370	--	--	--	--	--

# PRESSURE TEMPERATURE RATINGS

## 400# Bronze (GRAPH 3)

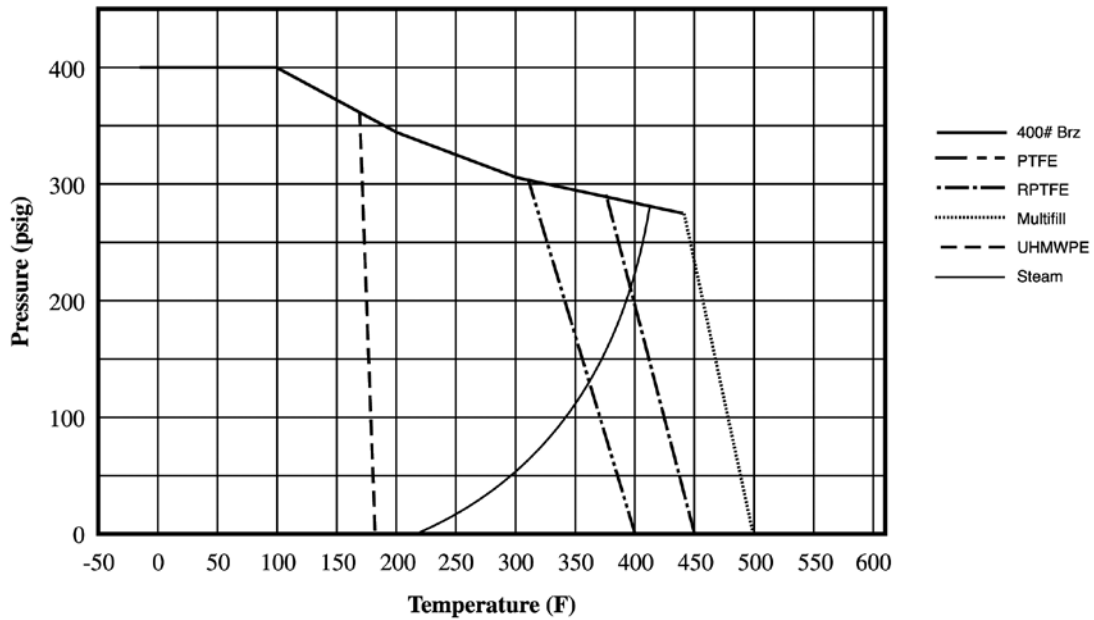

## 600# Bronze (GRAPH 4)

