

DIRTCAL® – DIRTMAG® dirt separator



01137/13 NA

5462–5463–5465–NA5469–NA5465 series



PCT
INTERNATIONAL
APPLICATION
PENDING

Function

In heating and air conditioning control systems, the circulation of water containing impurities may result in rapid wear and damage to components such as pumps and control valves. It also causes blockages in heat exchangers, heating elements and pipes, resulting in lower thermal efficiency within the system.

The dirt separator separates off these dirt particles which are mainly made up of particles of sand and rust, collecting them in a large collection chamber, from which they can be removed even while the system is in operation. This device is capable of efficiently removing even the smallest particles, with very low head loss.

The DIRTMAG® magnetic dirt separator removes both magnetic and non-magnetic particles continuously, featuring a powerful removable external magnet around the body that removes up to 95% of the ferrous oxide particles that can form in a hydronic system.

The sweat connection product is available in versions for horizontal and vertical pipe installations. The magnetic dirt separator is available with NPT threaded or sweat connections in versions for horizontal pipes only. Insulation shells are available separately for field installation for horizontal

Product range

5462 series	DIRTCAL® dirt separator for horizontal pipes, in brass	connections 3/4" to 2" NPT female and 1" to 2" sweat
5463 series	DIRTMAG® magnetic dirt separator for horizontal pipes, in brass.....	connections 1" to 2" sweat
5465 series	DIRTCAL® dirt separator for horizontal pipes, in steel.....	connections 2" to 4" ANSI flanged
NA5465 series	DIRTCAL® dirt separator for horizontal pipes, in steel, ASME & CRN	connections 2" to 6" ANSI flanged
NA5469 series	DIRTCAL® dirt separator for vertical pipes, in brass.....	connections 3/4" and 1" sweat

Technical specifications

Brass body dirt separators and magnetic dirt separators

Materials	- body, dirt collection chamber and top plug:	brass
	- internal element:	glass reinforced nylon PA66G30 (stainless steel, NA5469 series)
	- seal:	EPDM
	- drain valve:	brass
	- magnet (5463 series):	neodymium rare-earth

Performance

Suitable fluids:	water, glycol solution
Max. percentage of glycol:	50%
Max. working pressure:	150 psi (10 bar)
Temperature range:	32–250°F (0–120°C)
Particle separation efficiency:	to 5 µm (0.2 mil)
Magnetic particle separation efficiency:	for 5463 up to 95% removal

Connections	- main:	3/4", 1", 1-1/4", 1-1/2" and 2" NPT female 1", 1-1/4", 1-1/2" and 2" sweat
	- vertical:	3/4" and 1" sweat
	- top:	1/2" F (with plug)
	- drain:	3/4" garden hose connection
	- vertical:	hose connection

Steel body dirt separators

Materials	- body:	epoxy resin painted steel
	- internal element:	stainless steel
	- hydraulic seal:	fiber
	- drain valve:	brass

Performance

Suitable fluids:	water, glycol solution
Max. percentage of glycol:	50%
Max. working pressure:	150 psi (10 bar)
Temperature range without insulation:	32–250°F (0–120°C)
Particle separation capacity:	to 5 µm (0.2 mil)

Connections	- flanged:	2"–6" ANSI B16.5 150 CLASS RF
	- top:	3/4" M (with plug)
	- drain:	1" NPT

Agency approval - series NA5465 designed and built in accordance with Section VIII, Division 1 of the AMSE Boiler and Pressure Vessel Code and tagged and registered with the National Board of Boiler and Pressure Vessel Inspectors, CRN Registered.

Dimensions

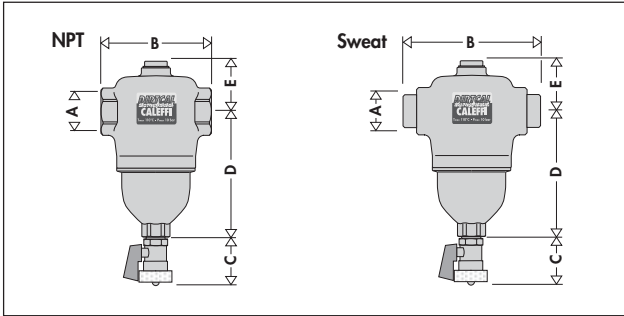

Code	A	B	C	D	E	Wt. lb (kg)
546205A	3/4" NPT	4 7/16"	1 1/4"	5"	2"	4.2 (1.9)
546206A	1" NPT	4 7/16"	1 1/4"	5"	2"	4.2 (1.9)
546207A	1 1/4" NPT	4 7/8"	1 1/4"	6"	2"	5.3 (2.4)
546208A	1 1/2" NPT	4 7/8"	1 1/4"	6"	2"	6.2 (2.8)
546209A	2" NPT	5 1/8"	1 1/4"	6"	2"	6.2 (2.8)
546228A	1" SWT	5 1/16"	1 1/4"	5"	2"	4.2 (1.9)
546235A	1 1/4" SWT	5 3/16"	1 1/4"	6"	2"	4.2 (1.9)
546241A	1 1/2" SWT	5 3/4"	1 1/4"	6"	2"	4.9 (2.2)
546254A	2" SWT	6 1/8"	1 1/4"	6"	2"	5.5 (2.5)

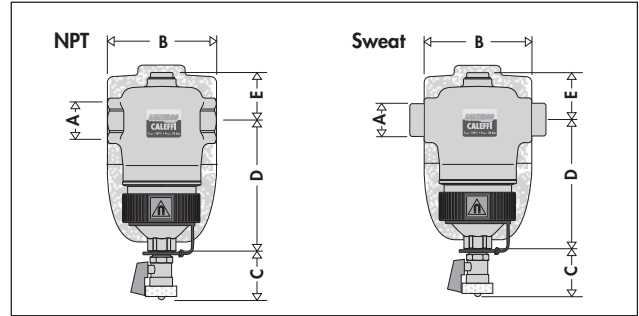

Code	A	B	C	D	E	Wt. lb (kg)
546306A	1" NPT	4 7/16"	1 1/4"	5"	2"	4.2 (1.9)
546328A	1" SWT	5 1/16"	1 1/4"	5"	2"	4.2 (1.9)
546307A	1 1/4" NPT	4 7/8"	1 1/4"	6"	2"	5.3 (2.8)
546335A	1 1/4" SWT	5 3/16"	1 1/4"	6"	2"	4.2 (1.9)
546308A	1 1/2" NPT	4 7/8"	1 1/4"	6"	2"	6.2 (2.8)
546341A	1 1/2" SWT	5 3/4"	1 1/4"	6"	2"	4.9 (2.2)
546309A	2" NPT	5 1/8"	1 1/4"	6"	2"	6.2 (2.8)
546354A	2" SWT	6 1/8"	1 1/4"	6"	2"	5.5 (2.5)

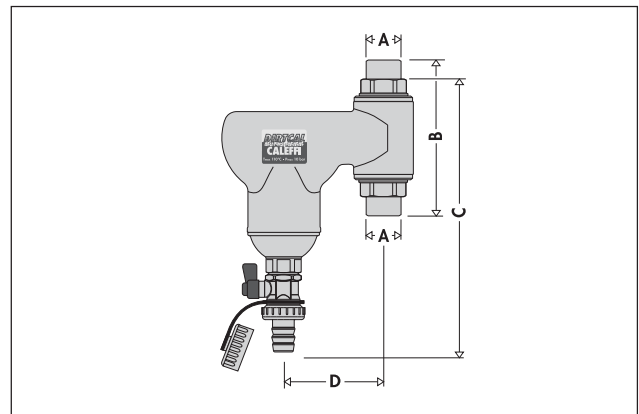
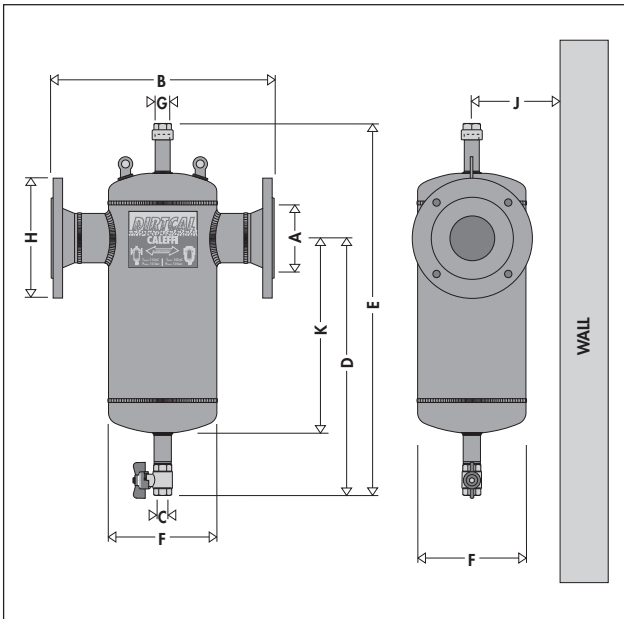

Code	A	B	C	D	Wt. lb (kg)
NA546995	3/4" SWT	5 7/8"	9 3/16"	3 3/16"	4.3 (1.95)
NA546996	1" SWT	6 1/4"	9 7/8"	3 3/16"	4.3 (1.95)

Code	A	B	C	D	E	F	G	H	J*	K	Capacity (gal)	Wt. lb (kg)
546550A	2"	13 3/4"	1"	14 3/4"	24 7/16"	6 5/8"	3/4"	6"	6 5/16"	12"	1.8	29 (13.0)
546560A	2 1/2"	13 3/4"	1"	14 3/4"	24 7/16"	6 5/8"	3/4"	7"	6 5/16"	12"	1.8	32 (14.5)
546580A	3"	18 5/8"	1"	17 1/8"	29 1/8"	8 5/8"	3/4"	7 1/2"	7 1/16"	13 3/8"	4.8	51 (23.0)
546510A	4"	18 1/2"	1"	17 1/8"	29 1/8"	8 5/8"	3/4"	9"	7 1/16"	13 3/8"	4.8	54 (24.0)
NA546550A	2"	13 3/4"	1"	16 1/16"	23 3/8"	6 5/8"	3/4"	6"	6 5/16"	12"	1.8	38 (17.0)
NA546560A	2 1/2"	13 3/4"	1"	16 1/16"	23 3/8"	6 5/8"	3/4"	7"	6 5/16"	12"	1.8	38 (17.0)
NA546580A	3"	18 5/8"	1"	20 1/16"	30 5/8"	8 5/8"	3/4"	7 1/2"	7 1/16"	13 3/8"	4.8	55 (25.0)
NA546510A	4"	18 5/8"	1"	20 1/16"	30 5/8"	8 5/8"	3/4"	9"	7 1/16"	13 3/8"	4.8	55 (25.0)
NA546512A	5"	25"	1"	23 3/16"	34 15/16"	12 3/4"	3/4"	10"	9 3/8"	17 3/16"	13.7	138 (63.0)
NA546515A	6"	25"	1"	23 3/16"	34 15/16"	12 3/4"	3/4"	10"	9 3/8"	17 3/16"	13.7	148 (67.0)

*This dimension allows for a minimum of 3" wall clearance to accommodate insulation if used.

Operating principle

The dirt separator operating principle is based on the combined action of a number of physical phenomena. The internal element (1) is composed of a set of concentric diamond pattern mesh surfaces. The dirt in the water strikes these surfaces, separates and drops into the bottom of the body (2) where they collect. In addition, the large internal volume of DIRTICAL® slows down the velocity of the medium and with the help of gravity, separates the contained particles.

The collected dirt can then be discharged, even with the system running, by opening the drain valve (3) with the handle (4).

Construction details

Low head losses and performance maintained over time

The dirt separating action performed by the dirt separator is based on using the internal element (1) with concentric diamond pattern mesh surfaces instead of an ordinary filter. The element offers little resistance to the medium flow while ensuring dirt separation. This occurs due to the particles colliding with the concentric diamond pattern mesh surfaces and then settling to the bottom, and not by filtration; which, over time, gets progressively clogged. By contrast, the DIRTICAL® low velocity- zone dirt separator efficiently removes the particles to as small as 5 µm (0.2 mil) with very low head loss. The dirt collection chamber (2) at the bottom of the DIRTICAL® is at the right distance from the inlet and outlet connections that the collected dirt particles are not affected by the swirling flow through the bottom drain port, even with the system running, by opening the drain valve (3) with the handle (4).

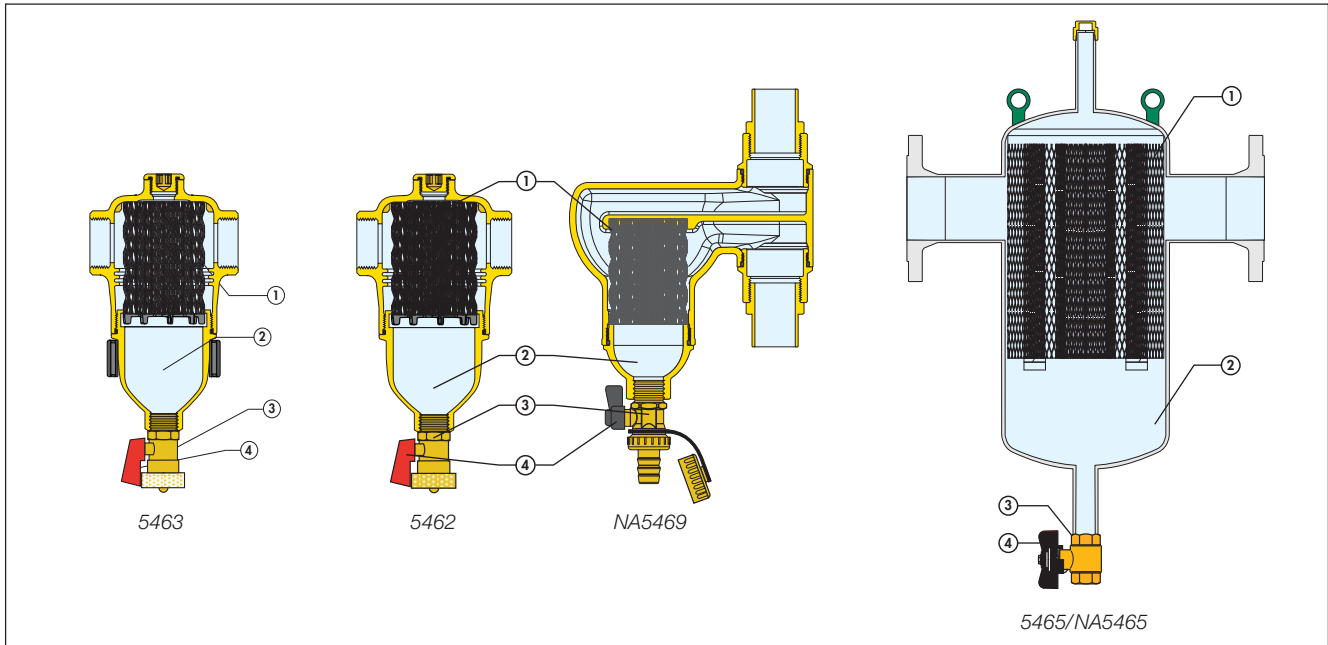

Geometric structure and large dirt collection chamber

The geometrical structure of DIRTICAL® reduces the flow media velocity to help separate dirt particles. The dirt collection chamber has the following features:

- It is located at the bottom of the device at such a distance from the connections that the collected dirt is not affected by the swirl of the flow through the mesh element.
- It has enough capacity to increase the amount of dirt stored and therefore decreases the frequency of emptying it compared to filters that need to be cleaned frequently.
- It is easily inspected, by unscrewing it from the dirt separator body for servicing the internal mesh element when large debris are trapped in it.



Vertical DIRTICAL®

The vertical DIRTICAL® dirt separator efficiently removes dirt particles with significantly less clogging of the internal mesh element compared to normal Y-strainers. Additionally, the large dirt collection chamber requires less frequent cleaning, which can be done by simply opening the drain valve to discharge the accumulated dirt particles, even with the system running. The special internal shape of the separator body is designed to maximize fluid flow rate with low head loss. Flow direction of the DIRTICAL® dirt separator is bi-directional; flow in either direction is permitted.



DIRTMAG®

The versatile DIRTMAG® magnetic dirt separator removes both magnetic and non-magnetic particles continuously. In addition to removing sand and rust impurities with a glass-reinforced nylon internal element in a low-velocity-zone chamber, the DIRTMAG® features a powerful removable external magnet around the body below the flow line for fast and effective capture of ferrous particles. The DIRTMAG® has the magnet positioned externally to maintain low pressure loss, and removes up to 95% of the ferrous oxide particles that can form in a hydronic system. Captured impurities are easily flushed by unclamping the collar and purging- even with the system still in operation.

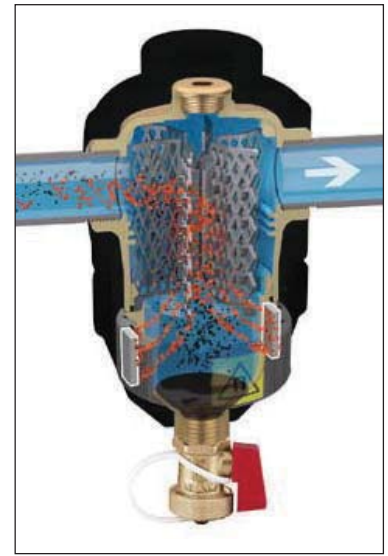

Draining off dirt

The dirt separator collection chamber has a drain valve. Using the handle provided it is possible to drain off the accumulated dirt particles even with the system in operation.

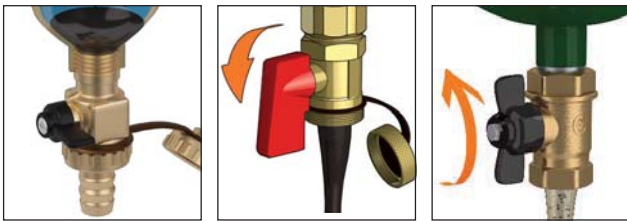

Maintenance

To perform maintenance, simply use a 26 mm hexagon wrench (1) to unscrew the dirt collection chamber, to which the inner mesh element is connected for removal and for cleaning.

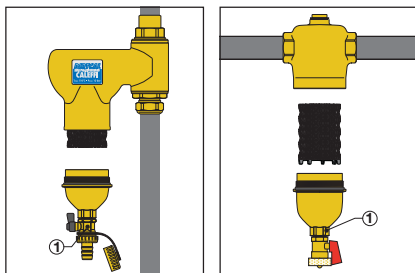

Use of top connector

The connector on top of the dirt separator can be used for optional installation of an automatic air vent valve, Caleffi code 502243A for the threaded or sweat versions, 5462 Series (A), replacing the standard 1/2" NPT Male plug (code NA10044). Use Caleffi code 501502A for the flanged version 5465 and NA5465 Series (C) — replacing the standard 3/4" NPT End Cap (code 41525).

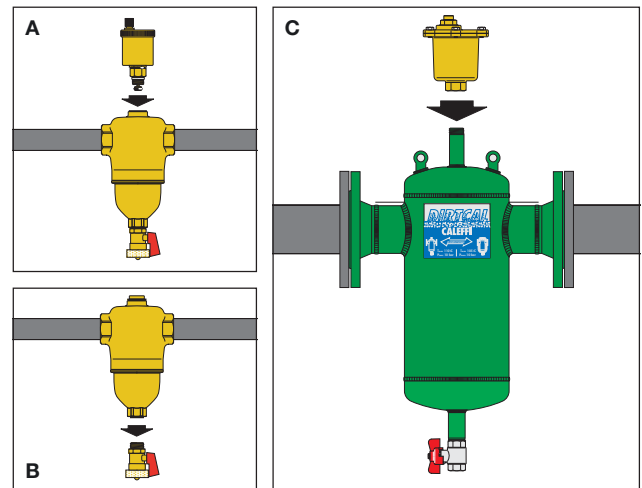

Use of bottom connector

The dirt separators come complete with drain valves installed on the bottom port: Caleffi code 538402 FD for horizontal threaded or sweat versions, 5462 series (B); code 538400 for vertical versions, NA5469 series and code NA39753 for flanges version, 5465 and NA5465 series (C).

Insulation shells

The brass DIRTAL® series 5462 for horizontal pipes and the DIRTMAG® series 5463 can be supplied with optional insulated covers, code CBN5462xx series purchased separately, to minimize heat loss.

Code	Size
CBN546205	For ¾" & 1" DIRTAL®, DIRTMAG®
CBN546207	For 1" & 1½" DIRTAL®, DIRTMAG®
CBN546209	For 2" DIRTAL®, DIRTMAG®

Technical specifications

Material:	closed cell expanded PE-X
Thickness:	25/64" (10 mm)
Density - inner part:	1.9 lb/ft³ (30 kg/m³)
- outer part:	3.1 lb/ft³ (50 kg/m³)
Thermal conductivity (DIN 52612):	
- at 32°F (0°C):	0.263 BTU·in/hr·ft²·°F (0.038 W/(m·K))
- at 104°F (40°C):	0.312 BTU·in/hr·ft²·°F (0.045 W/(m·K))
Coefficient of resistance to water vapor (DIN 52615):	>1,300
Working temperature range:	32–212°F (0–100°C)
Reaction to fire (DIN 4102):	class B2

Removing insulation and draining impurities (D)

1. Remove the insulation by taking off the bottom casing of the collection chamber first, and if necessary, the top insulation casing later.
2. Remove the magnetic ring containing the two magnets, that during operation attracted the ferrous particles.
3. Flush out the ferrous and nonferrous debris by turning the handle to open the drain valve.
4. When finished, replace the insulation shells.



Hydraulic characteristics

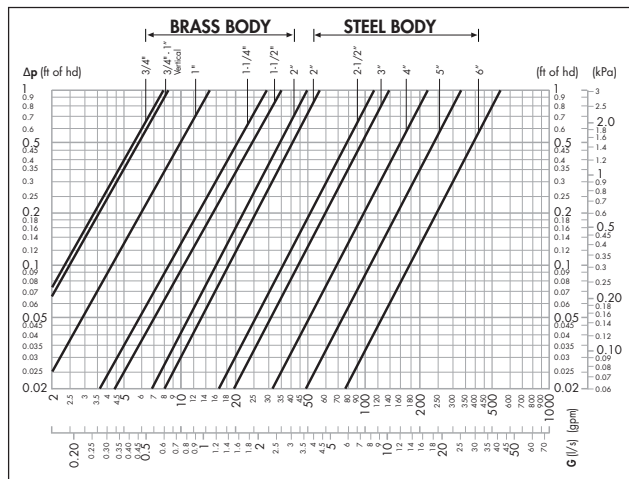

	Brass body						Steel body					
Size	¾"	¾"-1"	1"	1¼"	1½"	2"	2"	2½"	3"	4"	5"	6"
CV	18.8	19.9	32.6	56.6	73.3	81	88	176	211	328	520	842

*Vertical versions

The maximum fluid velocity recommended at the unit connections is ~ 4 f/s. The following table shows the maximum flow rates to comply with this condition.

	Brass body						Steel body					
Size	¾"	¾"-1"	1"	1¼"	1½"	2"	2"	2½"	3"	4"	5"	6"
GPM	6	9.0	9.3	15.3	23.9	36	37.3	63	95.5	149	259	380
l/s	0.4	0.57	0.6	1.0	1.5	2.28	2.35	3.9	6.0	9.4	16.3	24.0

*Vertical versions

Particle separation capacity – dirt separator efficiency

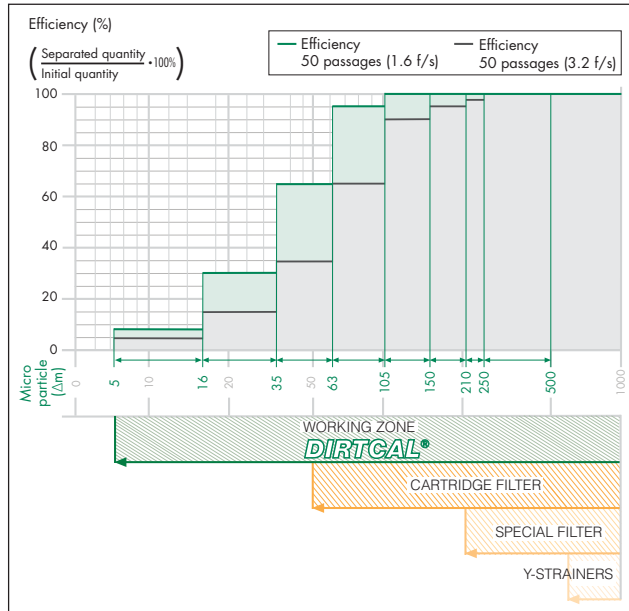

Reduced head losses

A normal Y strainer performs its function via a metal mesh selected for the size of the largest particle. The medium therefore has a consequent initial loss of head that increases as the degree of clogging increases.

Separation efficiency

The capacity for separating the dirt in the medium circulating in the closed circuits of the hydronic systems depends on three factors:

1. It increases as the size and mass of the dirt particle increases. The larger and heavier dirt particles drop before the lighter ones.
2. It increases as the fluid velocity decreases. If the velocity decreases, there is a low-velocity-zone inside the dirt separator and the dirt particles separate more easily.
3. It increases as the number of recirculations increases. The medium in the circuit, flowing through the dirt separator a number of times during operation, is subjected to a continuous separation, until the dirt particles are completely removed.

The special design of the internal mesh element in the Caleffi DIRTICAL® dirt separator, is able to completely separate the dirt particles in the circuit down to a minimum particle size of 5 µm (0.2 mil). The adjacent graph illustrates how DIRTICAL® quickly separates nearly all the dirt particles. After only 50 recirculations, approximately one day of operation, up to 100% is effectively removed from the circuit for particles of diameter greater than 100 µm (3.9 mil) and on average up to 80% taking account of the smallest particles. The continual passing of the medium during normal operation of the system gradually leads to complete dirt removal.

The DIRTICAL® dirt separator, however, removes the particles striking the internal mesh element and subsequently drop into the collection chamber. The consequent head losses are greatly reduced and are not affected by the amount of dirt collected.

Installation

The dirt separator must always be installed in a vertical position, preferably on the return circuit upstream of the boiler (or chiller). This enables it to intercept dirt particles already present in the circuit, particularly when it is first started, before they reach the boiler (or chiller). Flow direction for the DIRTICAL® and DIRTMAG® dirt separators is bidirectional, flowing in either direction is permitted.

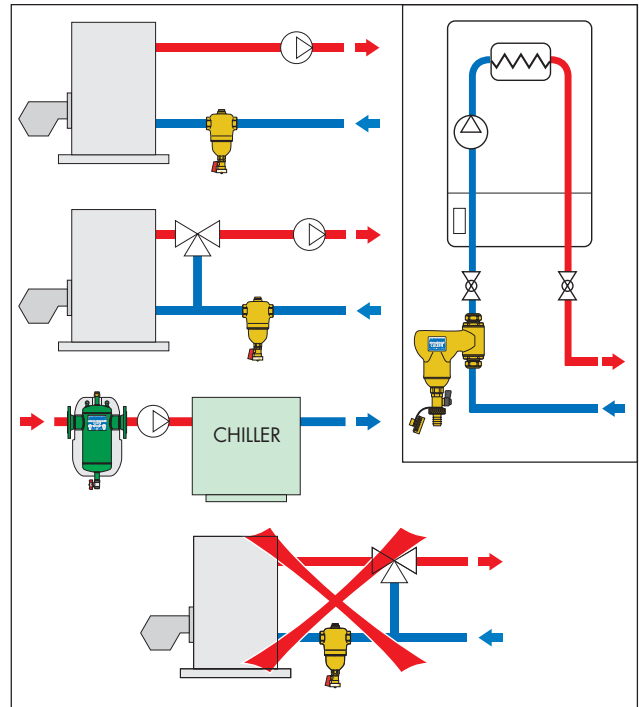
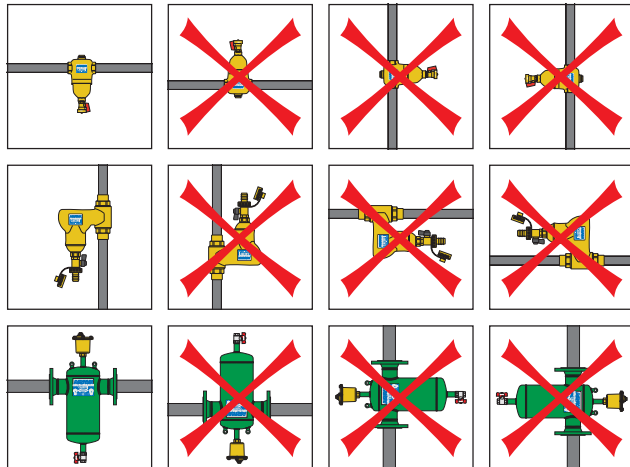

Application diagram

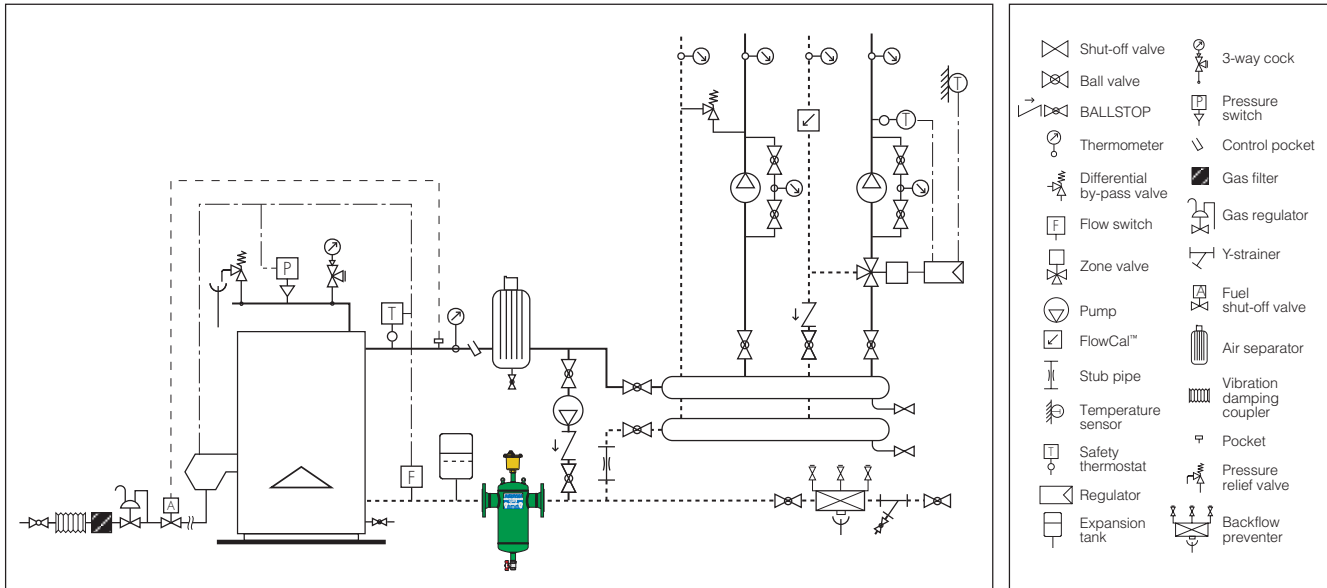

SPECIFICATION SUMMARIES

5462 Series DIRTCAL® — Brass with Sweat and NPT connections

Dirt separator in brass. NPT threaded connections from 3/4" to 2" and sweat connections 1" to 2". Top connection 1/2" F (with plug). Drain valve with 3/4" garden hose connection. Internal mesh element of glass reinforced nylon PA66G30, removable for cleaning. Brass body. EPDM hydraulic seals. Suitable fluids: water or 50% maximum glycol solution. Maximum working pressure 150 psi (10 bar), Temperature range 32 to 250°F (0 to 120°C). Particle separating capacity 5 µm (0.2 mil). Pre-formed insulation shells available separately for field installation.

5463 Series DIRTMAG® — Brass with Sweat and NPT connections

Dirt separator with magnet in brass. NPT threaded and sweat connections 1" to 2". Top connection 1/2" F (with plug). Drain valve with 3/4" garden hose connection. Internal mesh element of glass reinforced nylon PA66G30, removable for cleaning. Brass body with an external removable magnet belt, neodymium rare-earth. EPDM hydraulic seals. Suitable fluids: water or 50% maximum glycol solution. Maximum working pressure 150 psi (10 bar), Temperature range 32 to 250°F (0 to 120°C). Particle separating efficiency 5 µm (0.2 mil). Magnetic particle separation efficiency: Up to 95% removal. Pre-formed insulation shells available separately for field installation.

5465 Series DIRTCAL® — Flanged Steel

Dirt separator in steel. Flanged 150 CLASS ANSI connections from 2" to 4". Top connection 3/4" F (with plug). Bottom male 1" NPT for drain. Internal mesh element of stainless steel. Fiber hydraulic seals. Suitable fluids: water or 50% maximum glycol solution. Maximum working pressure 150 psi (10 bar). Temperature range 32 to 250°F (0 to 120°C). Particle separating efficiency 5 µm (0.2 mil).

NA5465 Series DIRTCAL® — Flanged Steel*

Dirt separator in steel. Flanged 150 CLASS ANSI connections from 2" to 6". Top connection 3/4" F (with plug). Bottom male 1" NPT for drain. Internal mesh element of stainless steel. Fiber hydraulic seals. Suitable fluids: water or 50% maximum glycol solution. Maximum working pressure 150 psi (10 bar). Temperature range 32 to 250°F (0 to 120°C). Particle separating efficiency 5 µm (0.2 mil).

*Flanged series NA5465 are designed and built in accordance with Section VIII, Division 1 of the **AMSE Boiler and Pressure Vessel Code** and **tagged and registered with the National Board of Boiler and Pressure Vessel Inspectors, CRN Registered.**

NA5469 Series DIRTCAL® — Brass with Sweat connections

Dirt separator in brass. For vertical pipe installations sweat connections 3/4" to 1". Drain valve with hose connection. Internal mesh element of stainless steel, removable for cleaning. Brass body. EPDM hydraulic seals. Suitable fluids: water or 50% maximum glycol solution. Maximum working pressure 150 psi (10 bar). Temperature range 32 to 250°F (0 to 120°C).

We reserve the right to change our products and their relevant technical data, contained in this publication, at any time and without prior notice.



Caleffi North America, Inc.
3883 W. Milwaukee Road
Milwaukee, WI 53208
Tel: 414-238-2360 · Fax: 414-238-2366
sales@caleffi.com · www.caleffi.us
© Copyright 2012 Caleffi North America, Inc.