

Installation & Maintenance Instructions

HYDRAMOTOR® PUSH-TYPE LINEAR ACTUATOR WITH WATERTIGHT ENCLOSURE

**AH2D
SERIES**

I&M No.V8714R1 – Sec. 1
(Section 1 of 2)

⚠ WARNING

To prevent the possibility of death, serious injury or property damage, the Hydramotor® Actuator must be installed and serviced only by a qualified service technician avoiding the following hazards:

- **Electrical hazard.** Turn off all electrical power to Hydramotor® Actuator. More than one circuit may exist.
- **Pressure hazard.** Depressurize valve and vent hazardous or combustible fluid to a safe area before inspection or removing the actuator or valve from service.
- **Explosion, fire or toxic gas hazards.** Extinguish all open flames and avoid any type of sparking or ignition during leakage testing.

Service Notices

These instructions are divided into two sections. Be sure to read, understand and follow all instructions on I&M No. V8714R1 – Section 1 and 2.

See separate V710 Gas Valve Installation and Maintenance Instructions for information on: Operation, Positioning, Mounting, Piping, Strainer or Filter Requirements, Flow Controls, Preventive Maintenance, and Cause of Improper Operation.

DESCRIPTION

AH2D Hydramotors® are self-contained linear, push-type actuators which extend when powered and retract by spring force upon power interruption.

The AH actuator is typically used for control of gas-fired heating equipment, commonly to open and close a valve or both a valve and damper. AH2D actuators position V710 Series gas valve assemblies.

OPERATION

Application of electrical power simultaneously drives an electric pump and closes a normally-open dump valve, resulting in up to 250 pounds of force on the actuator stem. This extends the actuator stem and attached valve poppet, to open the valve and/or damper.

Upon reaching the fully extended position, a travel limit switch interrupts power to the electric motor while maintaining power to the dump valve, thus stabilizing hydraulic pressure to hold shaft position. Position indicators on both sides of the actuator show the actual position of the valve stem.

Upon power interruption, the dump valve opens releasing hydraulic pressure, allowing the return spring to retract the stem and close the valve fully. Closing time is one second or less.

OPTIONAL FEATURES

- **Damper Shaft Arm** All components to mount damper arm on right side of actuator. Available with or without return spring.
- **Auxiliary Switch** One or two integral SPDT switches, field adjustable to actuate at any position of stroke.
- **Overtravel Proof-of-Closure Switch** A single factory set non-field adjustable SPDT switch to be used in conjunction with V710 Series Gas Valves with overtravel seal (V22 or V25 suffix in catalog number).

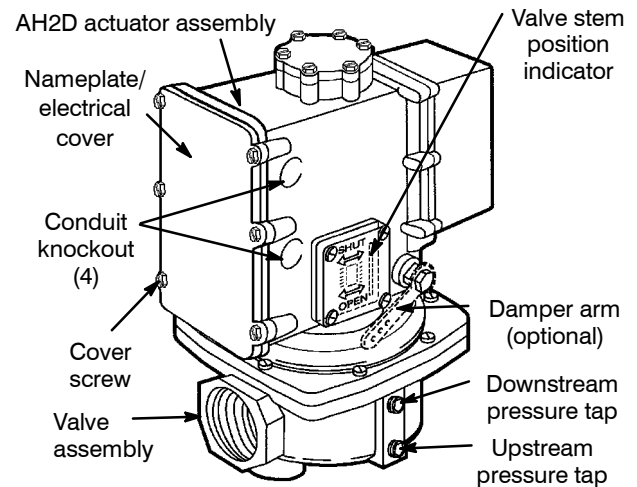

Figure 1. AH2D Actuator (shown mounted on V710 Series Gas Valve)

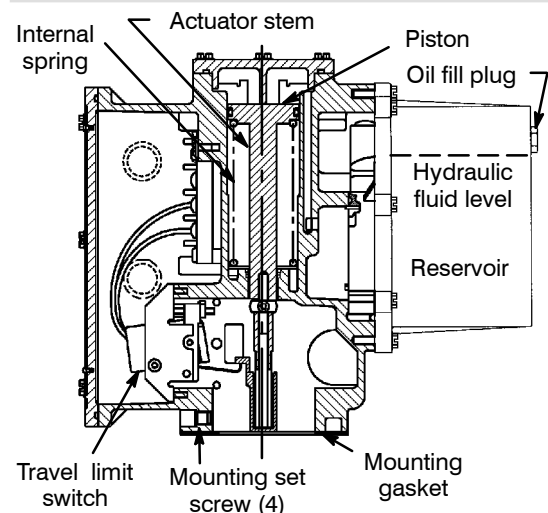

Figure 2. Cutaway View (de-energized)

SPECIFICATIONS

Force Output: 250 lbs

Stroke: 1 1/8" maximum

Electrical Characteristics:

Operating Voltage *	Amperes (nominal)		
	Inrush	Running	Holding
24V/50–60Hz	28.00	8.00	0.73
120V/50–60Hz	5.60	1.85	0.11
240V/50–60Hz	2.80	0.92	0.05

*50 Hz construction increases opening time 20%.

Opening Time: Fast Opening: 6 to 14 seconds
Slow Opening: 14 to 26 seconds

Note: Opening time doubles between -30°F to -40°F (-34°C to -40°C). Timing not field adjustable.

Maximum Closing Time: One second

Temperature Limitations: Ambient -40°F to 150°F (-40°C to 66°C)

Damper Arm Rating: Drives damper in one direction only. 20 lb maximum at 2.85 in. radius at 20°F to 150°F (-7°C to 65°C) and 10 lb maximum at -40°F to 20°F (-40°C to -7°C).

Damper Arm Travel: 2" maximum

INSTALLATION

Before installation, check nameplates to verify actuator and valve selected are appropriate for the application. **IMPORTANT: After actuator installation, test all functions and check out complete system before putting actuator/valve into service.**

Positioning/Mounting

Follow the V710 Series Gas valve and/or damper manufacturer's instructions when installing the Hydramotor®.

1. AH2D actuators can be installed to operate in any position.
2. Install mounting gasket and position the actuator to operate the valve (and damper if appropriate). Secure actuator with the four mounting set screws. Torque set screws to 80 ± 5 in-lbs [$9,0 \pm 0,5$ Nm] using a 5/32" hex key wrench.
3. For damper applications requiring the damper arm to return upon power failure, the optional return spring and spring plug (kit 440018) must be installed on the damper arm. Connect linkage so that damper returns to the desired position.

Wiring (Refer to Figure 3)

⚠ WARNING: Electrical hazard. To prevent the possibility of death, serious injury or property damage, open all circuits before inspection, service or disassembly. Reassemble before operating.

Wiring must comply with local codes and the National Electrical Code. Limit controls must conform to actuator rating (voltage, amperage, hertz). Wiring to meet NEC Class I, suitable for 75°C . Wire limit controls to the hot side of power supply.

1. Route wiring through one of the conduit knockout openings. Install appropriate electrical fittings.
2. For 120 VAC, connect the power wiring to terminals N (neutral) and L1 (hot). For 240 VAC, connect the power wiring to terminals L2 and L1 (hot). A green grounding screw with a cup washer is provided beside the terminal strip for grounding.
3. Torque terminal screws to 8 to 12 in-lbs [0,9 to 1,3 Nm].
4. Connect auxiliary or valve overtravel proof-of-closure switch wiring to the common and normally open or normally closed switch terminals.
5. Install nameplate/electrical cover with gasket and screws (6) on actuator housing. Hand thread screws as far as possible, then torque screws evenly in a crisscross manner to 30 to 35 in-lbs [3,4 to 4,0 Nm].
6. Operate actuator (complete system) through five cycles to verify proper operation.

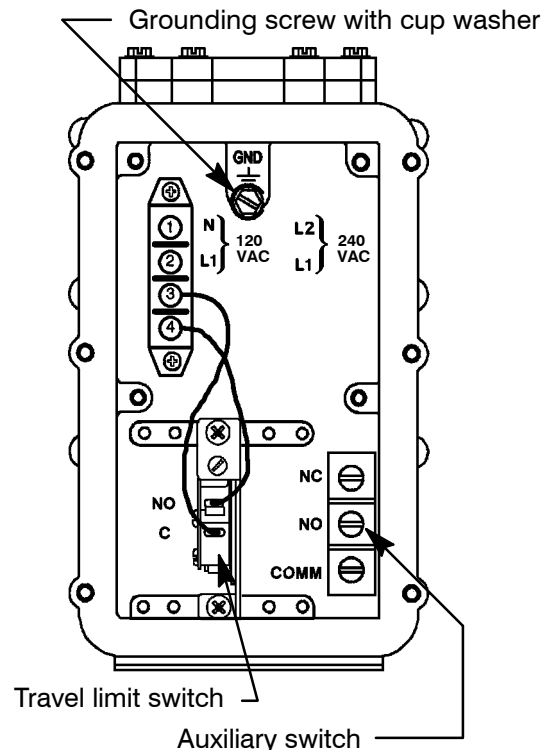

Figure 3. Typical AH2D Actuator Wiring.

Auxiliary and Overtravel Proof-of-Closure Switch Ratings

15 Amps 120 Vac
7.5 Amps 240 Vac

Total connected load of auxiliary and overtravel proof-of-closure switches not to exceed 1800 VA.

⚠ CAUTION: Overtravel Proof-of-closure switch must only be used with V710 Series Gas Valves having an overtravel seal (V22 or V25 Suffix in catalog number).

Overtravel Proof-of-Closure Switch

The optional valve overtravel proof-of-closure switch is set at the factory to provide both a mechanical and electrical means of proving valve closed position interlock to the primary control. This switch is not to be field adjusted.

Optional Auxiliary and Overtravel Proof-of-Closure Switch Combinations (Partial Views)

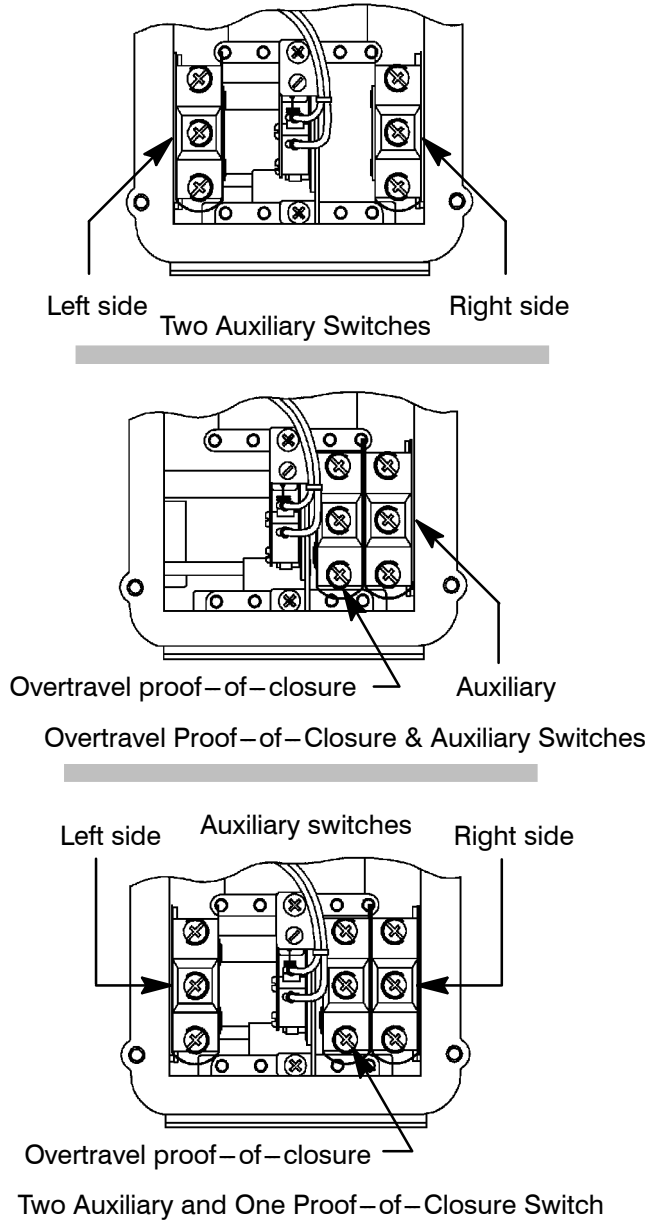

Auxiliary Switch Adjustment (Refer to Figure 4)

1. Remove window screws(4) and window with gasket.
2. Loosen the camlock screw no more than 1/2 turn.
3. Reset the cam adjustment screw to the desired switching point and hold this screw until camlock screw is tightened.
4. Tighten the camlock screw. Cycle the actuator to verify the switch setting and readjust as required.
5. Reinstall the window with gasket and torque screws evenly to 14 to 16 in-lbs [1,6 to 1,8 Nm].

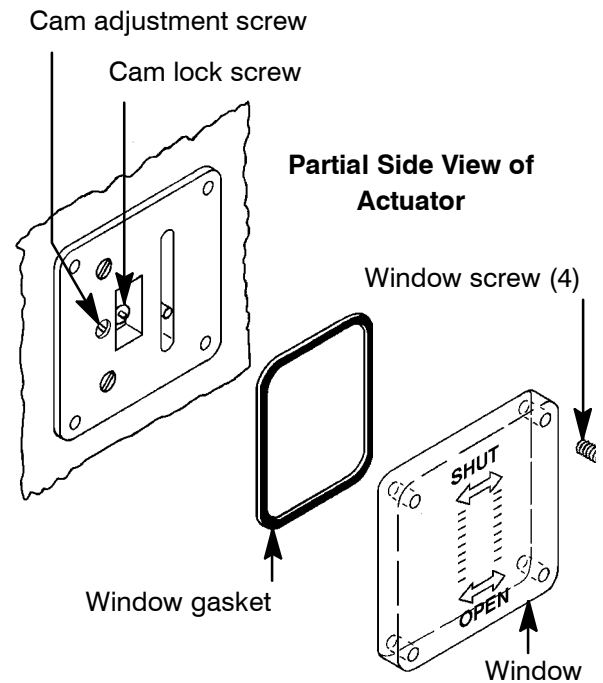

Figure 4. Auxiliary Switch Adjustment.

MAINTENANCE

Maintenance should include annual inspection and cleaning. Use a cleaning fluid compatible with actuator components to remove dirt and oil. Organize a maintenance schedule based on environment and frequency of use. Check for loose electrical and mechanical connections and replace damaged parts. **Before inspection, maintenance or rebuild, review WARNING statements on page 1.**

Field Service Notice

Field service replacement kits are limited to the following:

1. Travel limit switch Replacement Kit 440014.
2. Left side auxiliary switch Replacement Kit 440002.
3. Right side auxiliary switch Replacement Kit 440003.
4. Overtravel proof-of-closure switch Replacement Kit 440004*.
5. Right side combination auxiliary and overtravel proof-of-closure switch Replacement Kit 440012*.
6. Damper arm Replacement Kit 440018 (with spring and spring plug) or 440019 (without spring and spring plug).
7. Oil Replacement Kit 440008.
8. All gaskets and screws for enclosure Replacement Kit 440020. This kit contains the following:
 - Nameplate/electrical cover gasket and screws
 - Right & left window gasket and screws.
 - Valve/actuator mounting gasket and mounting set screws.

To order, specify the kit or part number, as well as the actuator model and serial numbers.

*Separate instructions provided with replacement kit.

Travel Limit Switch Replacement (Refer to Figure 5)

1. Remove the six cover screws and nameplate/electrical cover with gasket.
2. Disconnect wiring from travel limit switch.

▲ CAUTION: Label wires before disconnecting.

3. Remove two mounting screws and the travel limit switch.
4. Reinstall new travel limit switch in actuator. Torque mounting screws (2) evenly to 20 to 25 in-lbs [2,3 to 2, 8 Nm].
5. The required stroke is $1\ 1/8'' \pm 1/16''$. Turn adjustment screw located above limit switch until the desired stroke is achieved. Turn the adjustment screw clockwise to decrease stroke and counterclockwise to increase stroke.
6. Operate actuator (complete system) through five cycles to verify proper operation.
7. Reinstall nameplate/electrical cover with gasket and screws (6) on actuator housing. Hand thread screws as far as possible, then torque screws evenly in a crisscross manner to 30 to 35 in-lbs [3,4 to 4, 0 Nm].

Auxiliary Switch Replacement (Refer to Figure 6)

1. Remove six cover screws and nameplate/electrical cover with gasket.
2. Disconnect auxiliary switch wiring.

▲ CAUTION: Label wires before disconnecting.

3. On auxiliary switch side of actuator, remove window screws (4) and window with gasket.
4. Remove auxiliary switch mounting screws (2) from side of actuator.
5. Disengage auxiliary switch from indicator bar and remove switch from actuator.
6. Install new auxiliary switch and reassemble in reverse order of disassembly.
7. Torque auxiliary switch mounting screws (2) evenly to 14 to 16 in-lbs [1, 6 to 1,8 Nm].
8. Torque terminal screws 8 to 12 in-lbs [0, 9 –1, 3 Nm].
9. Reinstall the window with gasket and torque screws evenly to 14 to 16 in-lbs [1,6 to 1,8 Nm].
10. Reinstall nameplate/electrical cover with gasket and screws (6) on actuator housing. Hand thread screws as far as possible, then torque screws evenly in a crisscross manner to 30 to 35 in-lbs [3,4 to 4, 0 Nm].
11. Operate actuator (complete system) through five cycles to verify proper operation.

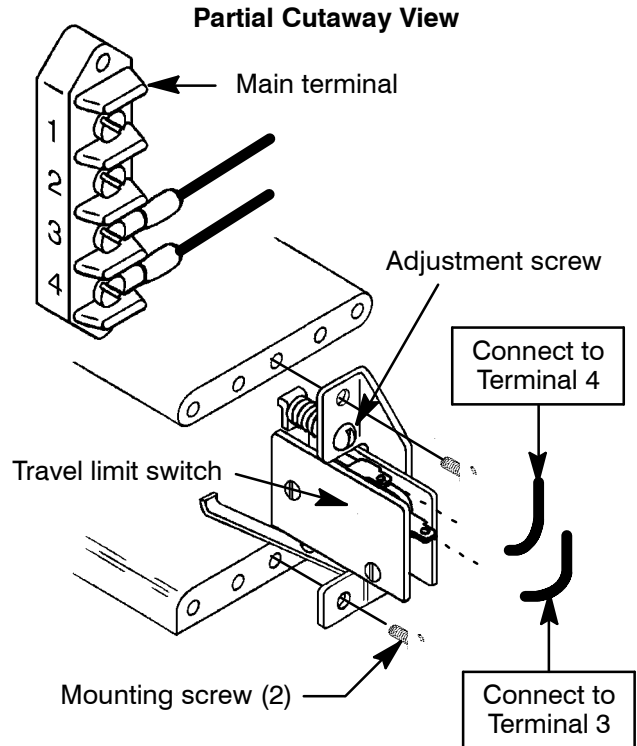

▲ CAUTION: Label wires before disconnecting.

Figure 5. Travel Limit Switch Replacement.

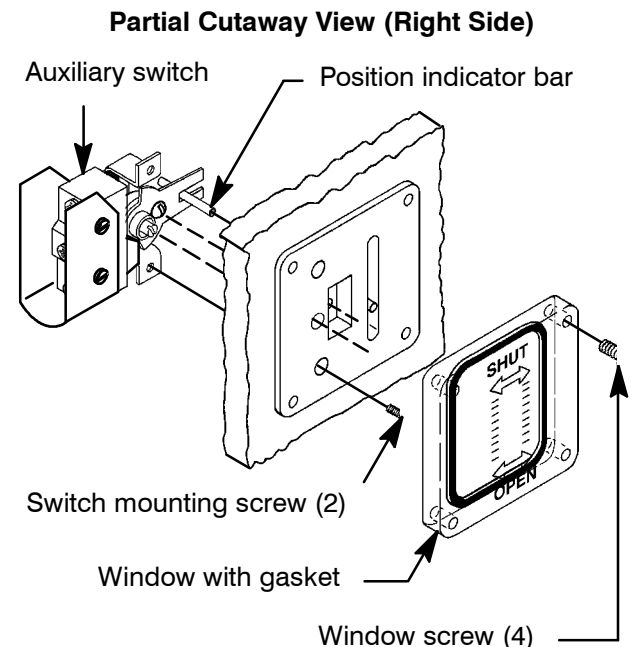

▲ CAUTION: Label wires before disconnecting.

Figure 6. Auxiliary Switch Replacement.

Continued on I&M No. V8714R1 -- Section 2.