



MODEL PRH

(36H SERIES)

High Capacity Water Pressure Reducing Valve

INSTALLATION

The APOLLO PRH must be installed in a conveniently accessible location to facilitate testing, repair and maintenance.

Flush upstream piping thoroughly to remove any foreign matter prior to installing the device.

Do not install the unit in areas subject to freezing temperatures.

INSTALL THE DEVICE WITH THE ARROW ON THE VALVE POINTING IN THE DIRECTION OF FLOW.

It is important that this unit be installed between shut-off valves in order to isolate the unit during repair and service.

Provide sufficient support on the piping system upon installation of this unit.

On units with strainer option, it is recommended to remove and clean the strainer screen periodically as service conditions warrant, to prevent malfunction.

OPERATION

The PRH is designed to reduce high supply pressure (up to 400 psig) to a lower outlet pressure within its adjustment range. The standard unit is factory set at 50 psig outlet pressure (static condition), and is adjustable from 25 to 75 psig (low and high pressure setting option available).

During static (no-flow) conditions, the valve is closed because the magnitude of the diaphragm force exposed to the downstream pressure is greater than the valve spring force. The balance of the forces on the supply and spring pressure (which tends to open the valve) against the diaphragm pressure, determines the outlet or reduced pressure downstream of the valve. Increasing the spring load through the adjusting screw will increase the set pressure. By decreasing the spring load (turning the adjusting screw counterclockwise), the set pressure decreases.

Under flow conditions, the pressure under the diaphragm will start to fall below the set pressure causing the spring and the supply pressure to open the valve and allowing more water to flow.

The amount of water that will pass through the valve depends on the difference between the inlet and the outlet pressure. As the pressure differential increases, the volume of water increases.

MAINTENANCE

Regular inspection, testing and cleaning of water pressure reducing valve and other components in a piping system assures maximum life and proper function.

The PRH is designed so that it can be serviced through the bottom plug without removing the cap and disturbing the pressure setting. Both the seat and seat disc assembly can be accessed through the bottom plug.

NOTE: PRIOR TO DISASSEMBLING THE UNIT, SHUT-OFF WATER SERVICE AND RELIEVE PRESSURE DOWNSTREAM.

- a) DISASSEMBLY OF SEAT
 1. Unscrew bottom plug.
 2. Unscrew seat disc holder.
 3. Remove seat.
- b) DISASSEMBLY OF SEAT DISC
 1. Remove bottom plug and seat disc holder.
 2. In the seat disc holder, remove seat disc by unscrewing the seat screw.
- c) DISASSEMBLY OF DIAPHRAGM

CAUTION: CAP IS SPRING LOADED. RELIEVE SPRING PRESSURE BY UNSCREWING THE ADJUSTING SCREW BEFORE ATTEMPTING TO REMOVE CAP!

 1. Remove cap bolts.
 2. Remove cap, spring retainer, and spring.
 3. Unscrew diaphragm nut.
 4. Remove diaphragm washer and diaphragm.
- d) DISASSEMBLY OF BY-PASS ASSEMBLY
 1. Unscrew bottom plug and remove seat disc holder.
 2. Relieve spring pressure on the cap and remove cap bolts. Dismantle the spring retainer and spring.
 3. Remove yoke with diaphragm attached. Do not unscrew diaphragm nut.
 4. Unscrew the by-pass assembly.

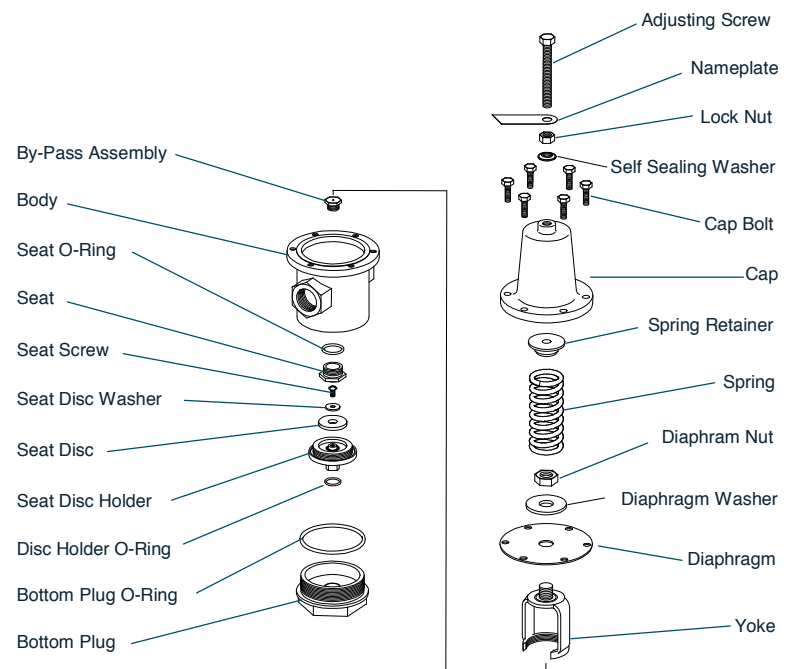

TROUBLE-SHOOTING

PROBLEM

1. Inlet pressure equalizes outlet pressure at no flow conditions.
2. Outlet pressure rises above inlet pressure.
3. Excessive noise within the pipeline at the PRH.

POSSIBLE CAUSE

- Leakage within the valve may be due to the following:
- (a) Seat disc not sealing tight against seat
 - (b) Seat O-ring may be cut or damaged
 - (c) Damaged or cut diaphragm
 - (d) By-pass leaking
- By-pass assembly not opening or clogged
Thermal expansion downstream
- High water velocity at the pipeline can sometimes cause a whistling noise or hum.

SOLUTION

- Inspect and replace if defective.
- Inspect and replace if defective.
- Replace
- Inspect by-pass washer and rubber ball. Rubber ball should move freely inside the housing. If defective replace the by-pass assembly.
- Disassemble the unit, clean and replace the by-pass assembly, if defective.
- Rubber ball should move freely inside the housing.
- Slight adjustment on the PRH may eliminate the noise. If not, the line or the PRH may be too small for the application.

DIMENSIONS (in.) & WEIGHTS (lbs.)

Size (NPT)	A	B	C	D	E	F	WGT. W/STRAINER	WGT. W/OUT STRAINER
1/2"	4-1/8	2-1/4	7	1-7/8	8-3/8	4	7	6
3/4"	4-1/8	2-1/4	7	2-7/16	9	4	7	6
1"	4-1/8	2-5/16	7-1/2	4	10-1/4	4-11/16	12	8
1-1/4"	6-3/4	3-3/16	10	3-3/8	12-1/2	6-1/2	29	24
1-1/2"	6-3/4	3-3/16	10	3-7/8	13-1/8	6-1/2	29	23
2"	8-1/8	3-1/2	12-1/2	4-5/8	16	7-5/8	47	38
2-1/2"	8-1/8	3-1/2	12-1/2	5-15/16	16-11/16	7-5/8	49	37
3"	10-3/8	3-15/16	15-1/8	6-15/16	20-1/2	9-3/4	87	70
Flanged								
2"	10-3/8	3-1/2	12-1/2	6-1/4	20	7-5/8	79	49
2-1/2"	10-3/8	3-1/2	12-1/2	7-1/8	21-11/16	7-5/8	105	55
3"	12-1/2	3-15/16	15-1/8	8-1/8	24-1/2	9-3/4	136	92

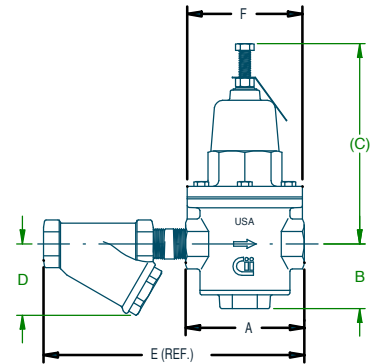

FLOW CURVES

Flow curves are based on static conditions of: Inlet pressure = 100 psig.
Outlet pressure = 50 psig

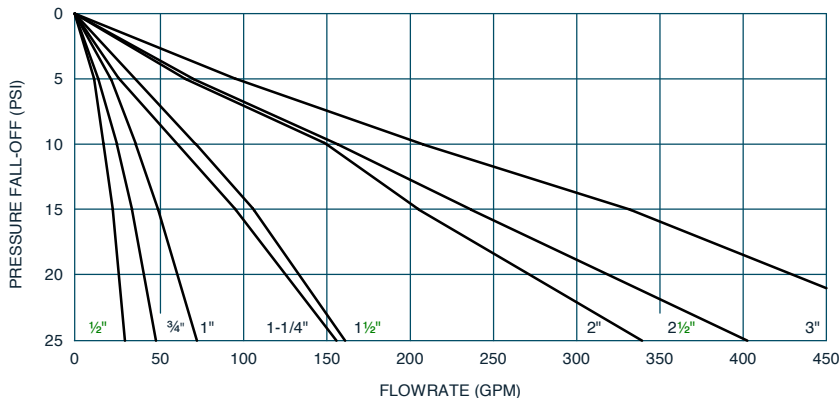

EXAMPLE: At static (no flow) conditions, inlet pressure of 100 psig and outlet set pressure of 50 psig (standard), a PRH-3/4" unit will deliver 23 gpm of water with a 10 psi fall-off (40 psi reduced flow pressure). If outlet set pressure at static condition is less than 50 psig, deduct 20% from capacity shown.

NOTES: 1) Repair kits contact factory

WARNING! This product contains chemicals known to the State of California to cause cancer and birth defects or other reproductive harm. (California law requires that this warning be given to the consumers in the State of California.) For more information visit www.apollovalves.com.

THIS PRODUCT MEETS THE REQUIREMENTS OF THE EPA SAFE DRINKING WATER ACT



CONBRACO INDUSTRIES INC.
1418 S. PEARL ST.
PAGELAND, SC 29728
TELEPHONE (704)841-6000
www.apollovalves.com