



1-1/2" P-TRAPS, MILWAUKEE CODE UTILITY TECHNICAL SPECIFICATION

Job Name _____	Item # _____
Location _____	
Engineer _____	Contractor _____
PO # _____	Tag _____
Representative _____	

SPECIFICATIONS

Dearborn 1-1/2" Brass Tubular P-Traps, Milwaukee Code Utility with Deep Flange are designed for use in tubular drain applications. Available in 17 or 20 Gauge Brass. Options include Brass Nuts and Cleanout.

DESCRIPTION

- Chrome Finish
- 1-1/2" P-Traps, Milwaukee Code Utility with Deep Flange
 - (1) Metal Flange
 - (1) Quarter Bend
 - (1) J-Bend
 - (2) Rubber Washers
 - (2) Nuts
- Includes 1-1/4" x 1-1/2" adapter

APPROVALS & LISTINGS



(783DF1- ONLY)

DIMENSIONS

*Includes 1-1/4" x 1-1/2" adapter

782DFBN-1

[A]:	Height A	3.78"	[D]:	Length D	1.5"
[B]:	Length B	10"	[E]:	Length E	1.5"
[C]:	Diameter C	1.5"	[F]:	Height F	1.5"

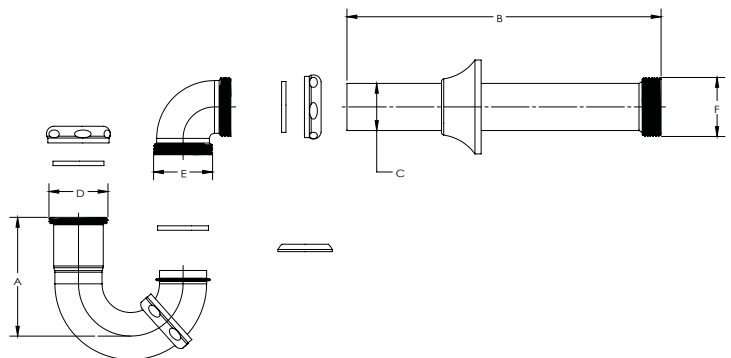

783DF-1

[A]:	Height A	5.2"	[D]:	Length D	1.5"
[B]:	Length B	10"	[E]:	Height E	1.5"
[C]:	Diameter C	1.5"	[F]:		

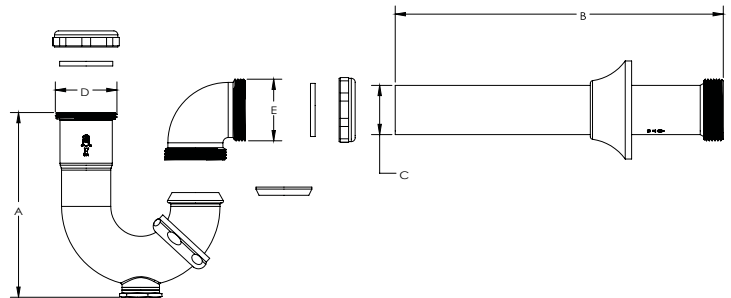

PRODUCT SELECTOR

1-1/2" P-TRAPS MILWAUKEE CODE UTILITY

✓	Product Number	Size	Description	Carton Quantity
	782DFBN-1	1-1/2"	20 Gauge P-Trap, Milwaukee Code Utility w/ Deep Flange & Brass Nuts	25
	783DF-1	1-1/2"	17 Gauge P-Trap, Milwaukee Code Utility w/ Deep Flange & Cleanout	25

Data is subject to manufacturing tolerances.

Access BIM/Revit content through www.oatey.com