

Balancing valve, variable orifice

142 series



Function

Caleffi 142 series low lead manual balancing valves are used to measure and adjust the fluid flow rate in hydronic or plumbing circuits. Turning the knob moves a plug within the fluid stream which varies the flow rate. The flow rate is determined from the pressure drop created across the two test ports as the fluid passes the adjustment plug. The pressure drop value is measured by a differential pressure meter connected to the pressure test ports. The valve design is variable orifice with pressure ports located upstream and downstream of the adjustment plug. A memory stop feature allows the valve to be closed, and later reopened to the original set position. Optional insulation shells are available, purchase separately.

Product range

142 series Variable orifice balancing valve

sizes 1/2", 3/4", 1", 1 1/4", 1 1/2", and 2" NPT female

Technical specifications

Materials

Valve: DZR low-lead brass
 Bonnet: DZR low-lead brass
 Valve adjustment plug: DZR low-lead brass
 Hydraulic seals: EPDM
 Adjustment knob: PA6G30
 Pressure test ports: DZR low-lead brass body, EPDM seal elements

Reduction of Lead in Drinking Water Act Compliant: 0.25% Max. weighted average lead content. Reduction of Lead in Drinking Water Act Certified by IAPMO R&T.

Performance

Suitable Fluids: water, glycol solutions
 Max. percentage of glycol: 50%
 Max. working pressure: 232 psi (16 bar)
 Working temperature range: 15 - 250°F (-10-120°C)
 Accuracy: ±15%
 Number of adjustment turns: 4
 Threaded connections: 1/2"- 2" FNPT

Insulation

Materials: EPP
 Thickness: 1/2 inch (15mm)
 Density: 2.8 lb/ft³ (45 kg/m³)
 Thermal conductivity (ISO 2581):
 - at 50°F (10°C): BTU · in/hr · ft² · °F (0.037 W/m · K)
 Working temperature range: 23 - 250°F (-5 - 120°C)
 Reaction to fire (UL 94): Class HBF

Dimensions

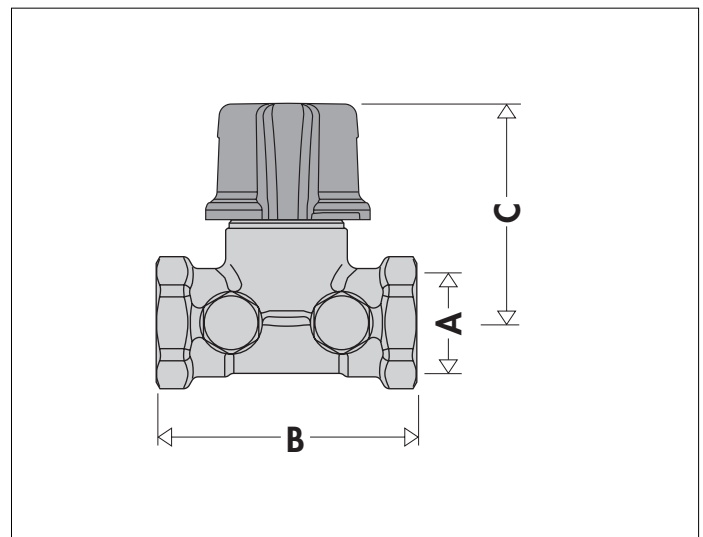

Code	A	B	C	Wt (lb)
142241A	1/2"	2 9/16"	2 1/2"	1.0
142251A	3/4"	2 15/16"	2 1/2"	1.2
142261A	1"	3 7/16"	2 1/2"	1.5
142271A	1 1/4"	3 3/4"	3 1/4"	2.3
142281A	1 1/2"	3 15/16"	3 3/8"	3.0
142291A	2"	4 3/4"	3 3/8"	3.5

Advantages of balanced circuits

Balanced circuits have the following principal benefits:

1. In hydronic applications, the system emitters operate properly saving energy and providing greater comfort.
2. In plumbing applications such as hot water recirculation, water is not wasted when there is a call for hot water from a fixture.
3. Circuit pumps operate at maximum efficiency, reducing the risk of overheating and excessive wear.
4. High fluid velocities which can result in noise, erosion and abrasion are avoided.
5. The differential pressures acting on the circuit control valves are reduced preventing faulty operation.

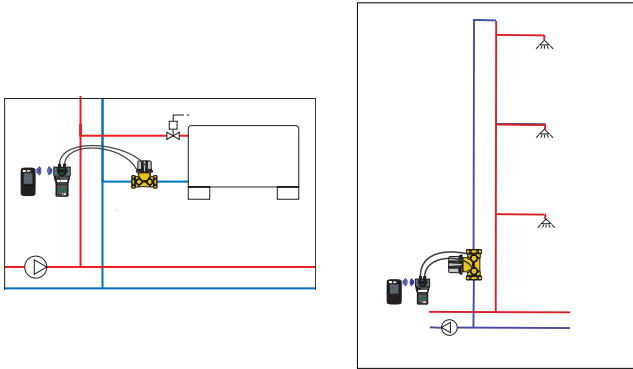

Operating principle

The 142 series balancing valve is a hydraulic device that controls the flow rate of a fluid. Turning the knob moves a plug within the fluid stream which varies the flow rate. The flow rate is determined according to the pressure drop value measured by a differential pressure meter connected to the pressure test ports and the adjustment knob position.

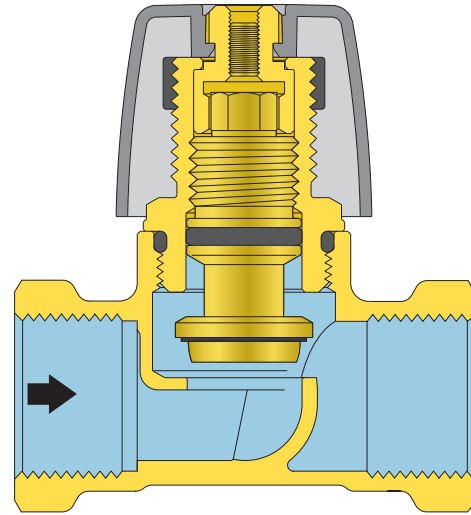

Construction details

Adjustment knob

The knob is made of a reinforced high strength corrosion-resistant polymer. The shape of the knob is designed to ensure maximum comfort for the operator and an accurate adjustment.

Adjustment reference scale

Each 360° rotation of the knob moves the turn indicator by one position, ranging from 0 (valve closed) to 4 (valve fully open).

Memory stop

After adjusting the flow rate, insert a 2.5 mm hex key in the hex hole, fully turn it clockwise without forcing it. This sets the valve's maximum stroke position. If necessary, it is possible to shutoff the balancing valve by turning the adjustment knob fully clockwise manually. To restore the valve to the pre-set position, turn the adjustment knob fully counter-clockwise.

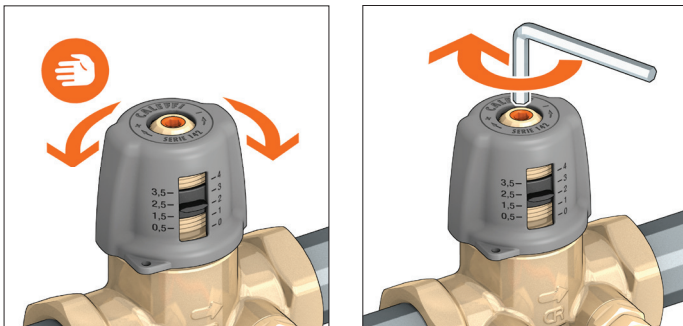

Fast-coupling pressure test ports

The 142 series balancing valve has as standard probe type, fast-coupling pressure test ports. The probe from the differential pressure meter is inserted into the port packing, until the end of the probe enters the system. When the measuring probe is pulled out, the test port automatically closes, preventing fluid leakage. Care should be taken to pull the probe out slowly so as to allow adequate time for the packing to re-seal – otherwise fluid can quickly escape creating a hazardous situation. Consult differential pressure meter manufacturer instructions for proper use of instrument and pressure port couplings.

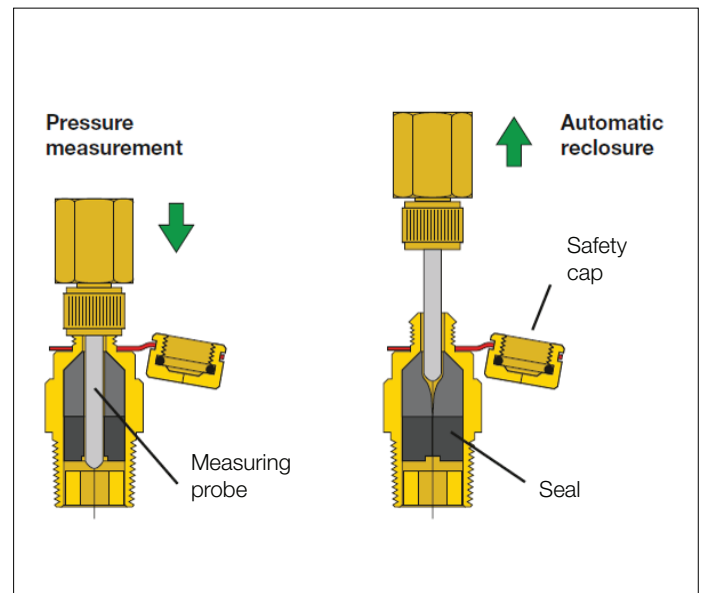

Insulation shells

The 142 series balancing valve can be supplied with optional insulation shells, code CBN142xxxx series purchased separately, to minimize heat loss or eliminate condensation in chilled water applications.

Code	Size
CBN142241A	Fits ½"
CBN142251A	Fits ¾"
CBN142261A	Fits 1"
CBN142271A	Fits 1¼"
CBN142281A	Fits 1½"

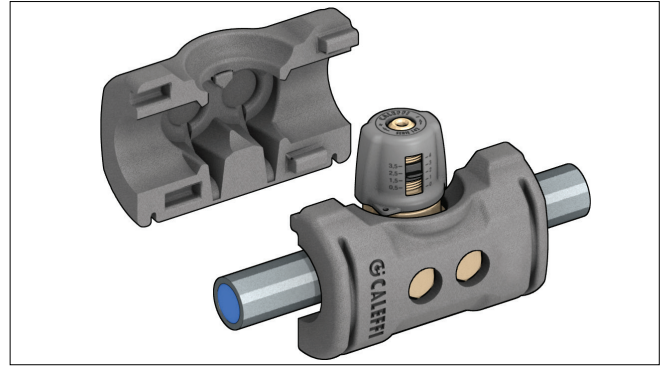

USING AND SETTING THE BALANCING VALVE

Measuring the flow rate

The 142 series balancing valves contain pressure test ports located upstream and downstream of the valve plug. As fluid flows through the valve and past the adjustment plug, a differential pressure across the two ports is induced. By measuring this differential pressure value and knowing the flow coefficient of the valve (corresponding to the knob position) the flow rate can be determined.

When fluid medium is water

When the fluid is water, the flow rate can be determined by either referencing the flow characteristics chart for the respective valve size, or by using the formula $G = C_v \cdot \sqrt{\Delta P}$ where G is the flow rate in gpm, C_v is the flow coefficient of the balancing valve, and ΔP is the pressure differential in psi.

Example (see graph on next page), for balancing valve code 142251A (¾") with the knob position set to position #2, and the differential pressure measured to be 3.0 psi, find the point on the chart where the 3.0 psi value intersects the position #2 line. Drop a line vertically to intersect the gpm axis and estimate the corresponding flow rate to be 3 gpm. Alternately, we can determine the flow rate G by substituting the values into the above formula: $G = 1.7\sqrt{3} = 3$ gpm, where 1.7 is the value C_v at position #2.

When fluid medium is other than water

A correction factor for calculating flowrate needs to be applied when using fluids with viscosities similar to water (which is the case for most glycol and salt based anti-freeze solutions). $G_A = \frac{G}{\sqrt{SG_F}}$, where G_A is the actual flow rate of the fluid, G is the calculated value from the chart or formula, and SG_F is the specific gravity of the fluid.

For example, if a 50% polypropylene glycol solution is the medium instead of water, we must first determine the specific gravity, which is 1.04. The actual flow rate can be calculated as: $G_A = \frac{G}{\sqrt{SG_F}} = \frac{3.0}{\sqrt{1.04}} = 3/1.02 = 2.94$ gpm.

Code 142251A 3/4"

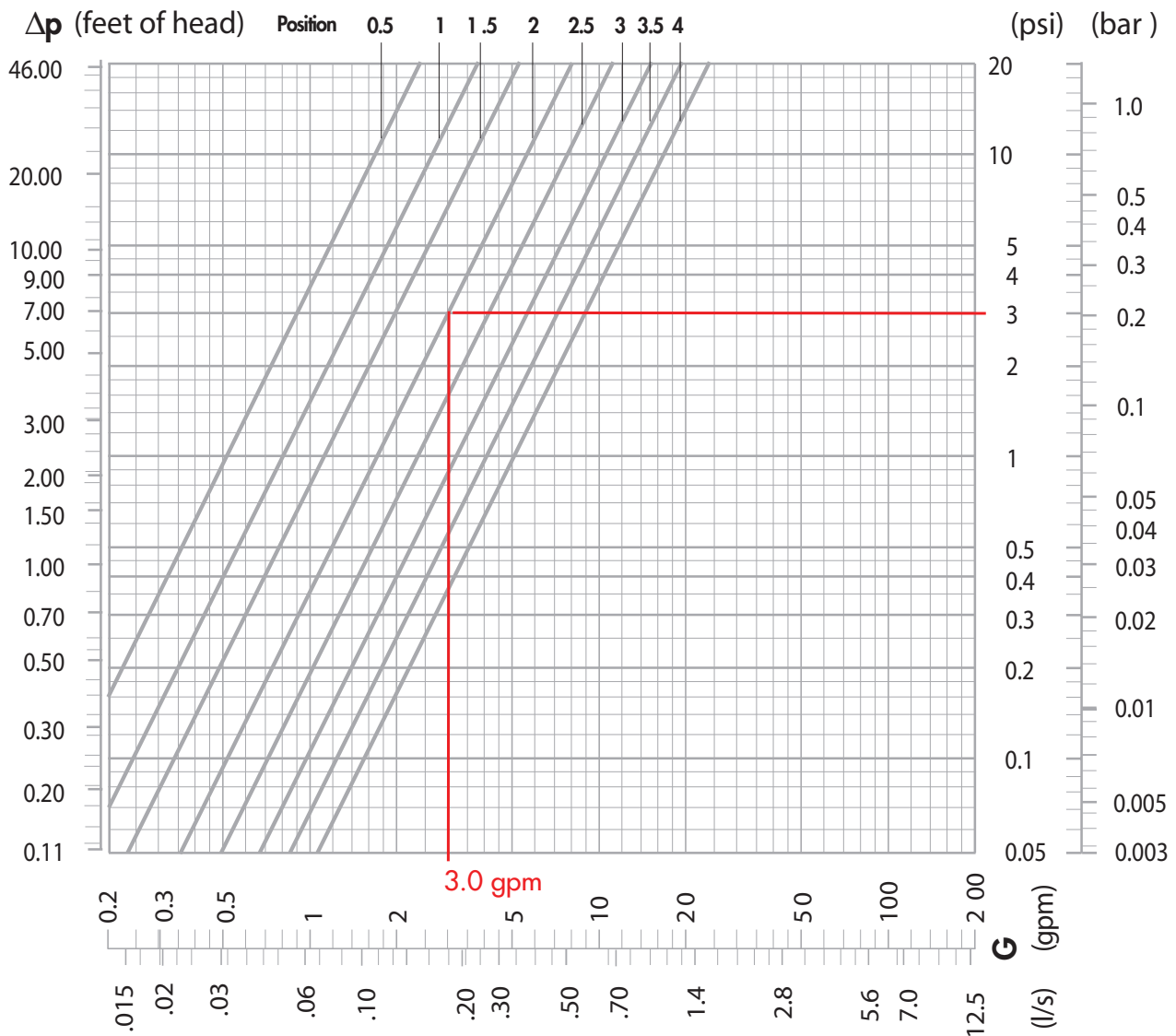

	Position							Cv Max
Size 3/4"	0.5	1	1.5	2	2.5	3	3.5	4
Cv	0.55	0.8	1.2	1.7	2.4	3.7	4.4	5.0

Benefit

For a given flow rate and valve size, the variable orifice type design results in a greater differential pressure signal than fixed orifice designs. In very low flow applications, the differential pressure value from a fixed orifice design can be small in relation to the accuracy tolerance of the measuring instrument. As a result, for such applications, the variable orifice design, which delivers a higher value in relation to measurement accuracy tolerance, can result in more precise balancing.

Effect of fluid conditions

To ensure accurate pressure measurement, care should be taken to ensure fluid is of high quality and absent of particles. Fluid impurities can cause erratic pressure signal readings, especially at very low flow rates or when the valve is closed more than 75% of full open. In hydronic applications, it is advised to use a dirt strainer, filter or separation device to protect against particles and debris.

USING AND SETTING THE BALANCING VALVE

Presetting

The 142 series balancing valve features highly graduated adjustment which facilitates pre-setting. In commercial balancing applications where multiple balancing valves are used, significant labor time can be saved in the balancing process if in advance of being installed, the valves are pre-set to the expected knob position value. To pre-set, the anticipated pressure drop across the valve is required. For example, if it has been calculated that to accomplish a flow rate of 3.0 gpm in a circuit, a 3.0 psi pressure drop across the balancing valve will be required, the knob should be preset to position #2.

Code 142241A 1/2"

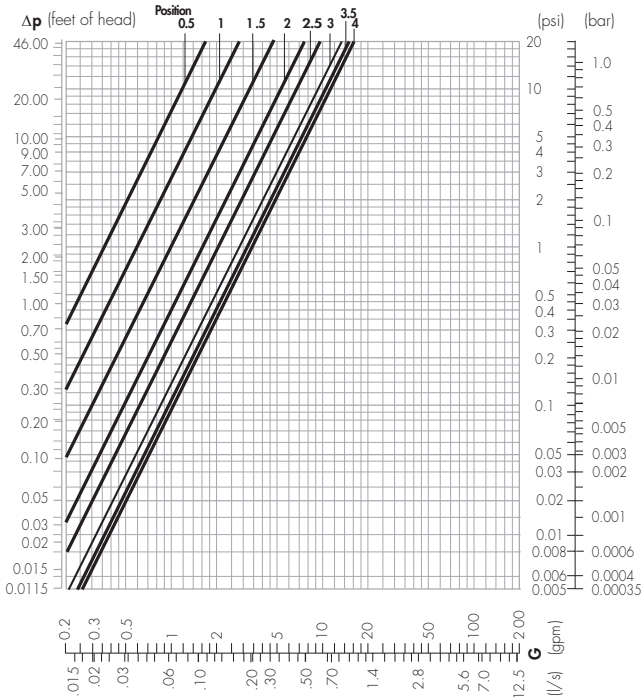

	Position							Cv Max
Size 1/2"	0.5	1	1.5	2	2.5	3	3.5	4
Cv	0.37	0.63	1.07	1.6	2.13	2.9	3.3	3.4

Code 142251A 3/4"

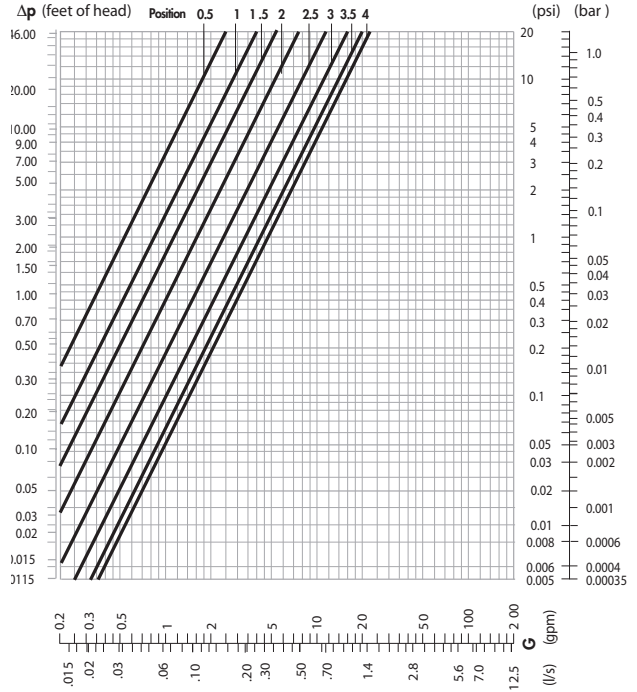

	Position							Cv Max
Size 3/4"	0.5	1	1.5	2	2.5	3	3.5	4
Cv	0.55	0.8	1.2	1.7	2.4	3.7	4.4	5.0

Code 142261A 1"

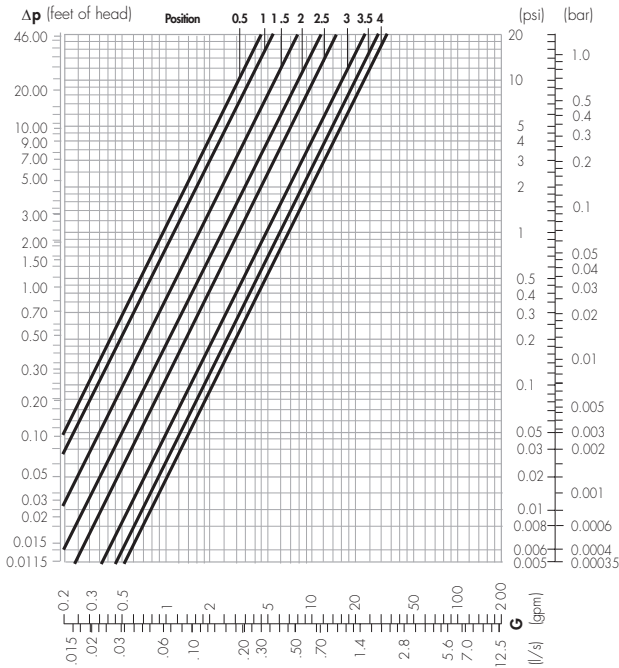

	Position							Cv Max
Size 1"	0.5	1	1.5	2	2.5	3	3.5	4
Cv	1.0	1.2	1.8	2.6	3.3	5.0	6.5	7.5

Code 142271A 1 1/4"

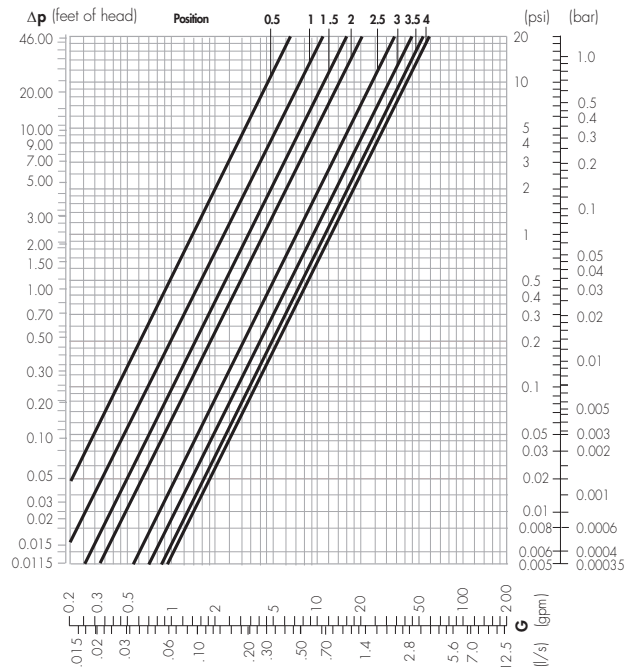

	Position							Cv Max
Size 1 1/4"	0.5	1	1.5	2	2.5	3	3.5	4
Cv	1.5	2.6	3.6	4.5	7.7	10.0	11.8	12.9

Code 142281A 1 1/2"

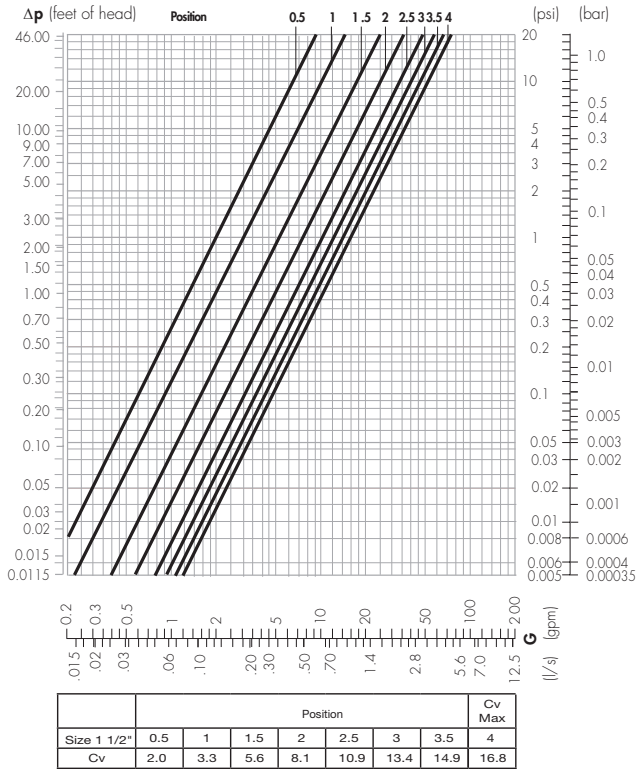

Code 142291A 2"

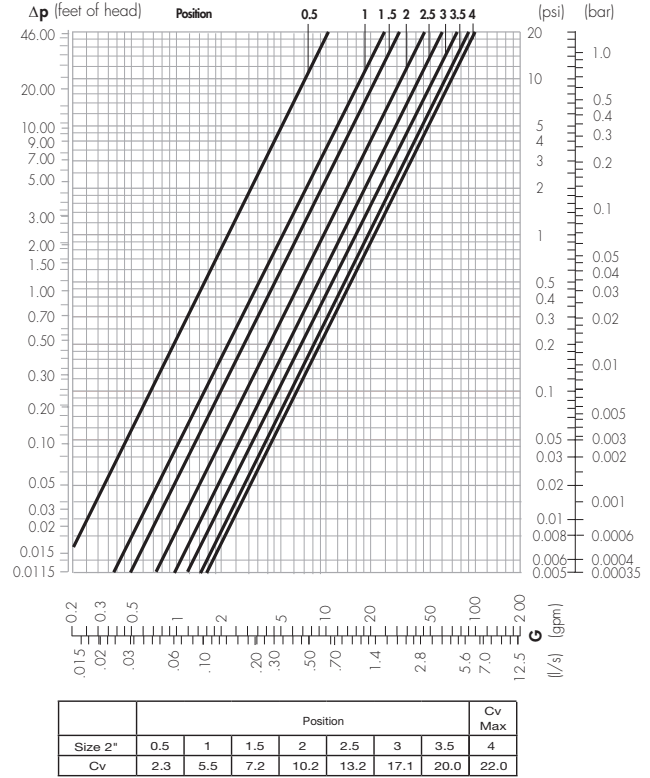

Valve flow coefficient Cv versus knob position						
Knob position	1/2" 142241A	3/4" 142251A	1" 142261A	1 1/4" 142271A	1 1/2" 142281A	2" 142291A
0.5	0.37	0.55	1.0	1.5	2.0	2.3
1.0	0.63	0.8	1.2	2.6	3.3	5.5
1.5	1.07	1.2	1.8	3.6	5.6	7.2
2.0	1.6	1.7	2.6	4.5	8.1	10.2
2.5	2.13	2.4	3.3	7.7	10.9	13.2
3.0	2.9	3.7	5.0	10.0	13.4	17.1
3.5	3.3	4.4	6.5	11.8	14.9	20.0
max 4.0	3.4	5.0	7.5	12.9	16.8	22.0

Flow formulas

$$\Delta p = (G/Cv)^2$$

$$G = Cv \cdot \sqrt{\Delta p}$$

$$Cv = \sqrt{\frac{G}{\Delta p}}$$

Application diagrams

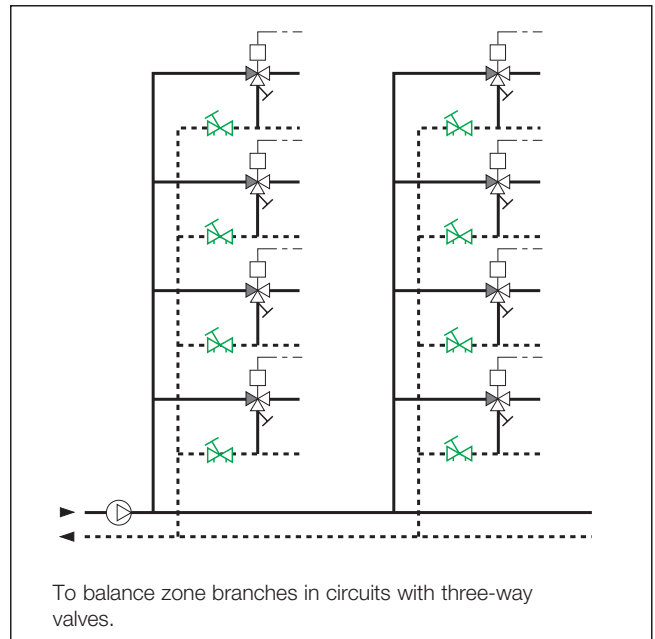
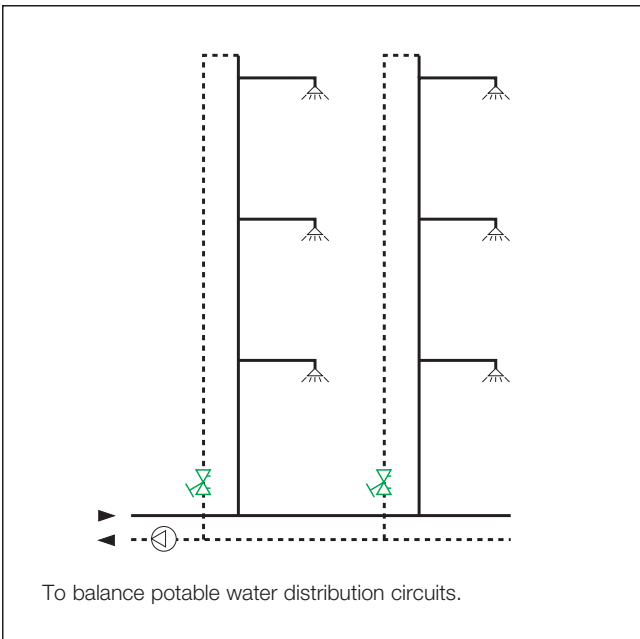
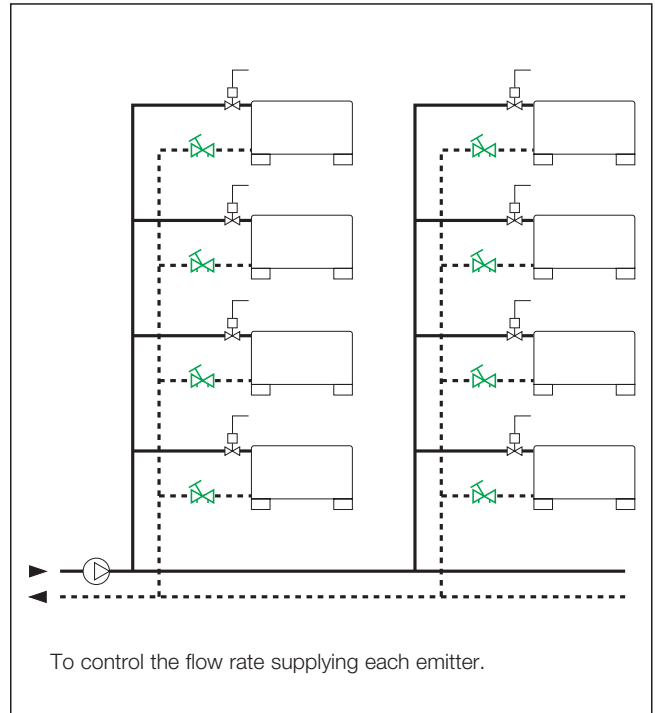
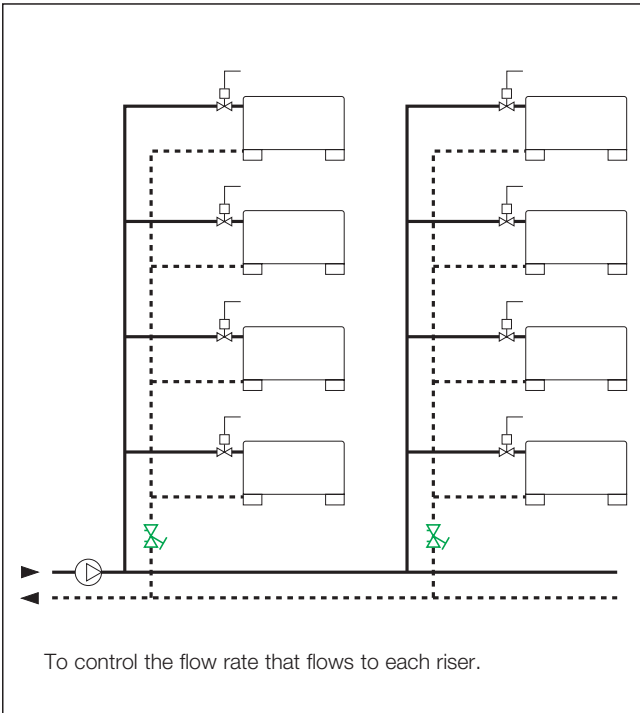

Application diagrams

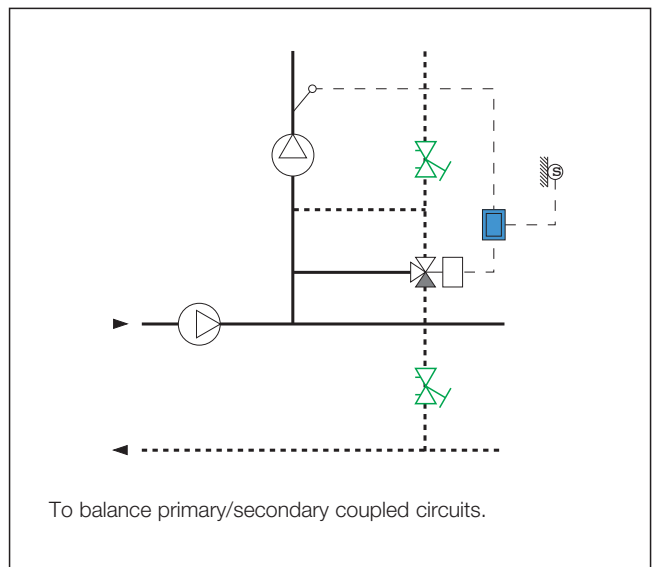
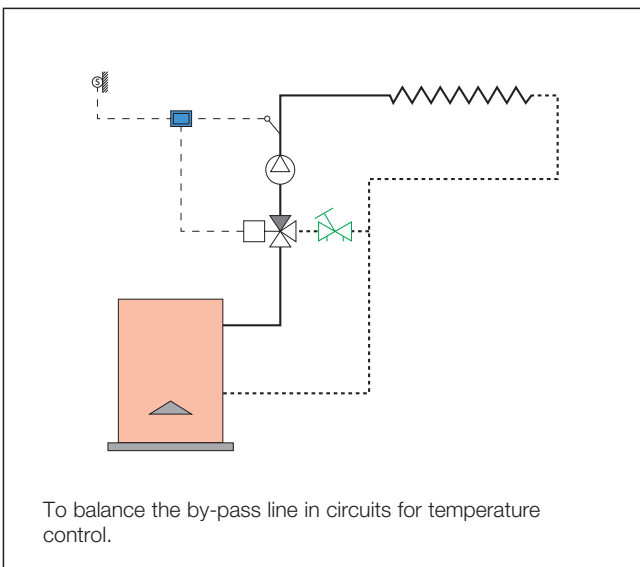
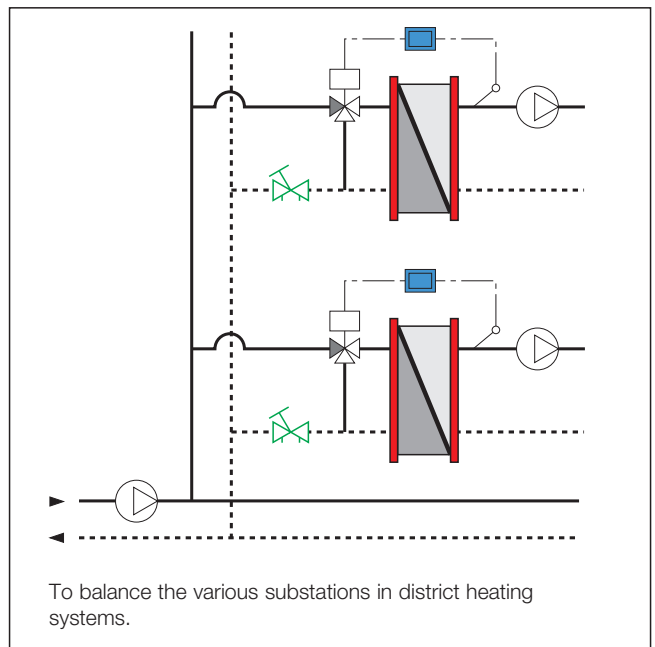
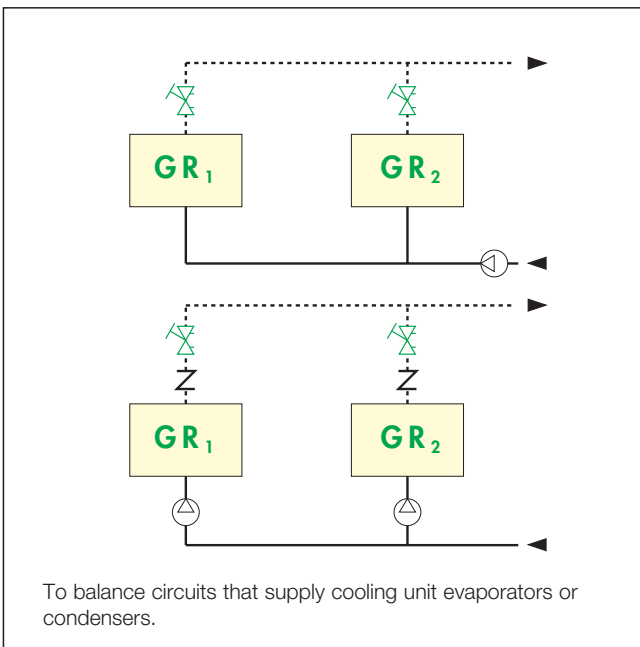
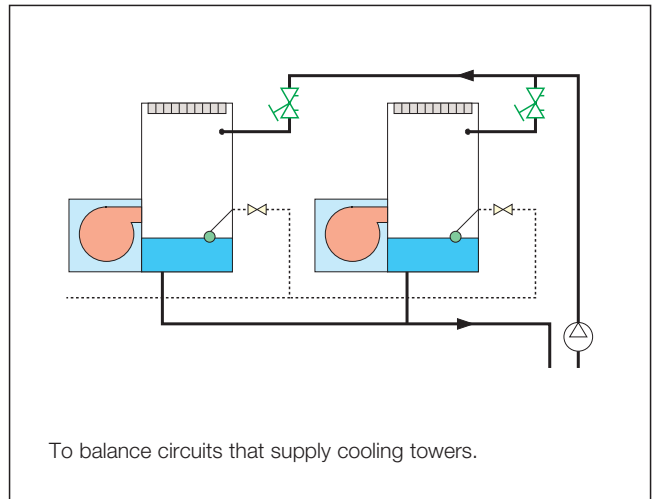
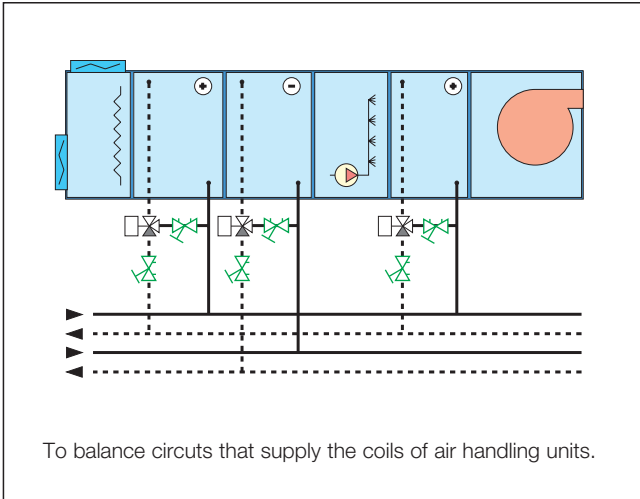

SPECIFICATION SUMMARIES

142 series

Balancing valve with variable orifice. Threaded connections 1/2", 3/4", 1", 1-1/4", 1-1/2", 2" NPT Female by Female. DZR low-lead brass body, bonnet and valve plug (< 0.25% lead content) certified by IAPMO R&T. EPDM hydraulic seals. PA6G30 adjusting knob with memory stop. Pressure test ports with DZR low-lead brass body and EPDM seal elements. Water and glycol solutions. Maximum percentage of glycol 50%. Maximum working pressure 232 psi (16 bar). Working temperature range 15 to 250 deg F (-10 to 120°C). Number of adjustment turns: 4. Accuracy \pm 15%. Pre-formed insulation shells available for field installation.

We reserve the right to change our products and their relevant technical data, contained in this publication, at any time and without prior notice.



Caleffi North America, Inc.
3883 W. Milwaukee Road
Milwaukee, WI 53208
Tel: 414-238-2360 · Fax: 414-238-2366
sales@caleffi.com · www.caleffi.us
© Copyright 2015 Caleffi North America, Inc.