

QuickSetter+™ Low-lead balancing valve with flow meter

132 series



Function

The QuickSetter+™ manual balancing valve contains a built-in flow meter and sight gauge, negating the need for differential pressure gauges and reference charts. Circuit balancing is fast, easy and accurate. Constructed of DZR low-lead brass, QuickSetter+™ is ideally suited for use in plumbing applications such as hot water recirculation systems. The built-in check valve protects against circuit thermo-siphoning. The outlet temperature gauge (optional) verifies the fluid temperature in the circuit. The flow meter sight gauge is dry (not exposed to the fluid) thus eliminating the possibility of gauge clouding/ scaling over time.

Product range

132 series Balancing valve with flow meter, includes check valve and optional outlet temperature gauge _____ sizes 1/2", 3/4", 1"

Technical specifications

Materials

Valve

Body: DZR low-lead brass
 Ball: stainless steel
 Ball control stem: brass, chrome plated
 Ball seal seat: PTFE
 Control stem guide: PSU
 Seals: EPDM

Flow meter

Body and headwork: DZR low-lead brass
 Bypass valve stem: stainless steel
 Springs: stainless steel
 Seals: EPDM
 Flow meter float and indicator cover: PSU

Reduction of Lead in Drinking Water Act Compliant: 0.25% Max. weighted average lead content. Reduction of Lead in Drinking Water Act Certified by IAPMO R&T.

Performance

Suitable Fluids: water, glycol solutions
 Max. percentage of glycol: 50%
 Max. working pressure: 150 psi (10 bar)
 Working temperature range: 14 - 230°F (-10-110°C)
 Flow rate range unit of measurement: 1/2 - 1 3/4 gpm
 2 - 7 gpm
 Accuracy: ±10%
 Control stem angle of rotation: 90°
 Control stem adjustment wrench: 9 mm

Sweat connections: 1/2", 3/4", 1"

Flow rate ranges

Code	Connection	Flow rate (gpm)	Fully open Cv
132439AFC	1/2" sweat	0.5 - 1.75	1.0
132539AFC	3/4" sweat	0.5 - 1.75	1.0
132639AFC	1" sweat	0.5 - 1.75	1.0
132459AFC	1/2" sweat	2.0 - 7.0	6.3
132559AFC	3/4" sweat	2.0 - 7.0	6.3
132659AFC	1" sweat	2.0 - 7.0	6.3

Code	Connection	Flow rate (gpm)	Fully open Cv
132438AFC*	1/2" sweat	0.5 - 1.75	1.0
132538AFC*	3/4" sweat	0.5 - 1.75	1.0
132638AFC*	1" sweat	0.5 - 1.75	1.0
132458AFC*	1/2" sweat	2.0 - 7.0	6.3
132558AFC*	3/4" sweat	2.0 - 7.0	6.3
132658AFC*	1" sweat	2.0 - 7.0	6.3

*with temperature gauge.

Dimensions

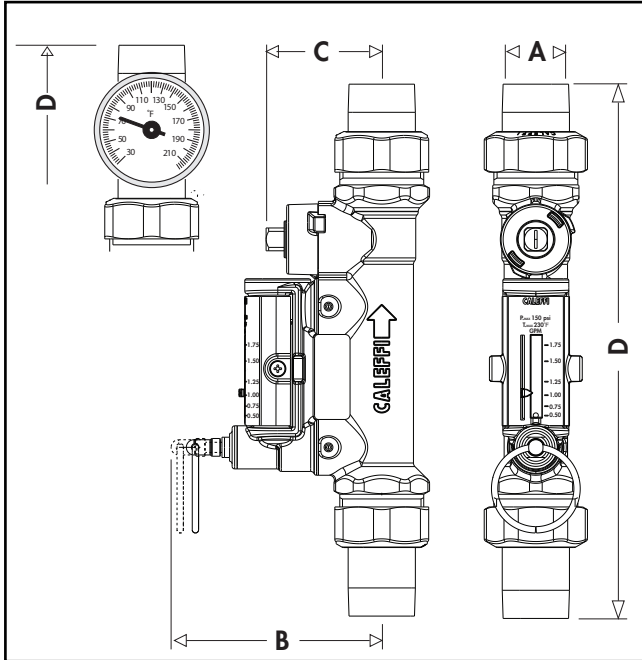

Code	A	B	C	D	Wt (lb)
132439AFC	1/2"	3 5/16"	1 13/16"	8 3/8"	2.00
132539AFC	3/4"	3 5/16"	1 13/16"	8 7/16"	2.10
132639AFC	1"	3 5/16"	1 13/16"	8 9/16"	2.25
132459AFC	1/2"	3 5/16"	1 13/16"	8 3/8"	2.00
132559AFC	3/4"	3 5/16"	1 13/16"	8 7/16"	2.10
132659AFC	1"	3 5/16"	1 13/16"	8 9/16"	2.25

Code	A	B	C	D	Wt (lb)
132438AFC*	1/2"	3 5/16"	1 13/16"	9 11/16"	2.50
132538AFC*	3/4"	3 5/16"	1 13/16"	9 13/16"	2.60
132638AFC*	1"	3 5/16"	1 13/16"	10 1/8"	2.70
132458AFC*	1/2"	3 5/16"	1 13/16"	9 11/16"	2.50
132558AFC*	3/4"	3 5/16"	1 13/16"	9 13/16"	2.60
132658AFC*	1"	3 5/16"	1 13/16"	10 1/8"	2.70

*with temperature gauge.

Balancing made fast, easy, and accurate with QuickSetter+

Hot water recirculation systems are designed to minimize wait time for hot water to arrive when a fixture is opened. Systems left unbalanced or improperly balanced result in wasted water down the drain, a costly and environmentally unfriendly situation - not to mention the undesired annoyance placed on building occupants. The QuickSetter+ takes the guess work and labor out of balancing. With the valve's exclusively designed venturi mechanism, the installer simply pulls the flow indicator by-pass pin, adjusts the flow to the desired flow rate while viewing the built-in sight gauge, and releases the pin. Easy, accurate balancing in seconds. No instruments or reference graphs are needed.

Balanced example

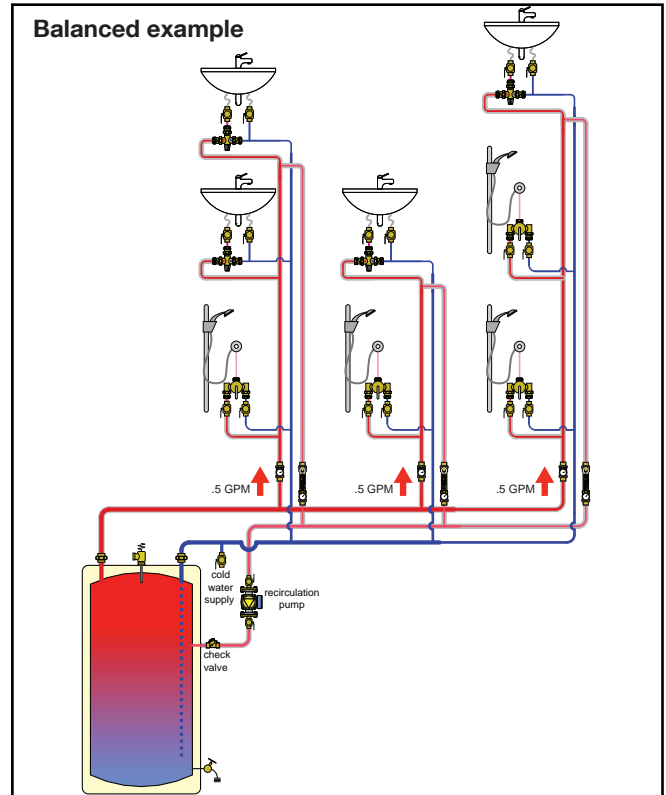

Unbalanced example

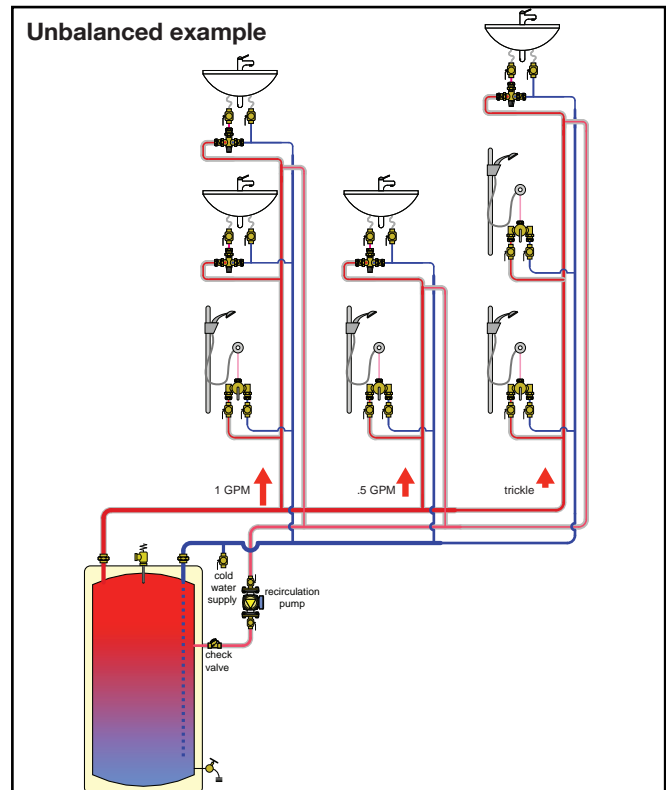

Operating principle

The balancing valve is a hydraulic device that controls flow rate.

The control mechanism is a ball valve (1), operated by a control stem (2). The flow rate is manually and properly set by use of the convenient onboard flow meter (3) housed in a bypass circuit on the valve body. This circuit is automatically shut off during normal operation. The flow rate is indicated by a metal ball (4) sliding inside a transparent channel (5) with an integral graduated scale (6).

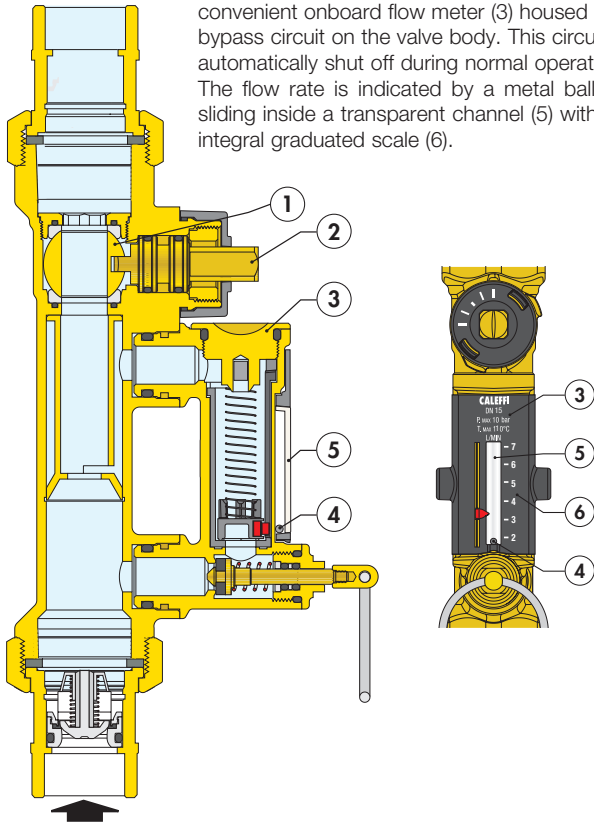

Hydraulic characteristics at 100% open

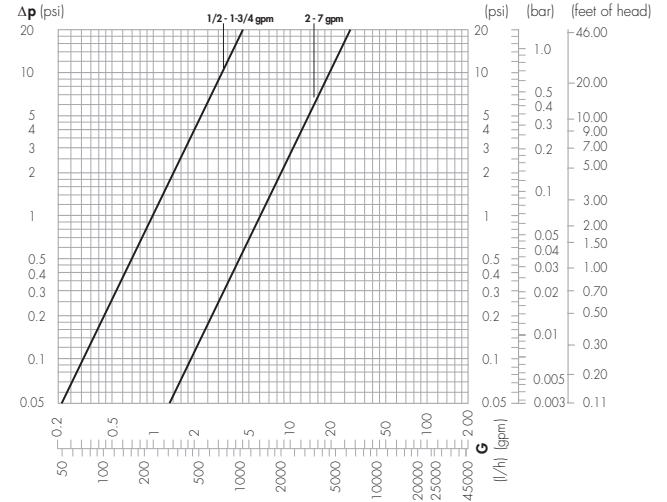

Connection	Flow rate (gpm)	Fully open Cv
1/2" sweat	0.5 - 1.75	1.0
3/4" sweat	0.5 - 1.75	1.0
1" sweat	0.5 - 1.75	1.0
1/2" sweat	2.0 - 7.0	6.3
3/4" sweat	2.0 - 7.0	6.3
1" sweat	2.0 - 7.0	6.3

Construction details

Flow meter

When activated by pulling the operating ring (2), the flow rate is indicated on the flow meter housed in a bypass circuit on the valve body. When finished reading the flow rate, the flow meter is automatically shut off, isolating it during normal operation. Use of a flow meter greatly simplifies the process of system balancing since the flow rate can be measured and controlled at any time without differential pressure gauges or reference charts. The onboard flow meter eliminates the need to calculate valve settings during system setup. Additionally, the unique onboard flow meter offers unprecedented time and cost savings by eliminating the long and difficult procedure of calculating pre-settings associated with using traditional balancing devices.

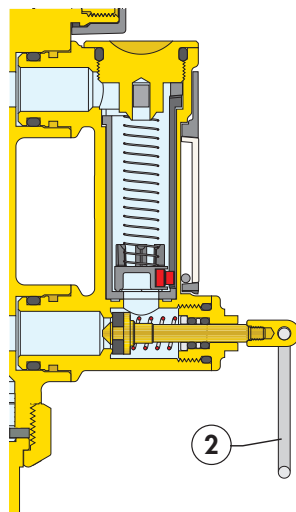

Flow meter bypass valve

The bypass valve (1) opens and closes the circuit between the flow meter and the valve. The bypass valve is easily opened by pulling the operating ring (2), and is automatically closed by the internal return spring (3) when finished reading the flow rate. The spring and the EPDM seal (4) provide a reliable seal to isolate the flow meter during normal operation.

The operating ring (2) material has low thermal conductivity to avoid burns if the flow meter is opened while hot fluid is passing through the valve.

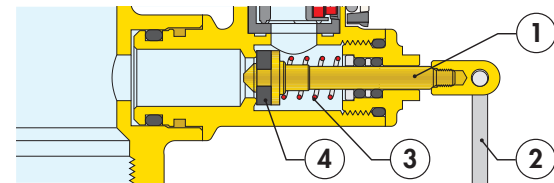

Ball/magnet indicator

The metal ball (4) that indicates the flow rate is not in direct contact with the fluid passing through the flow meter.

This is an effective and innovative measuring system in which the ball slides up and down inside a transparent channel (5) that is isolated from the fluid flowing through the body of the flow meter. The ball is moved by a magnet (6) connected to a float (7). In this way the flow rate indication system **remains perfectly clean and provides reliable readings over time.**

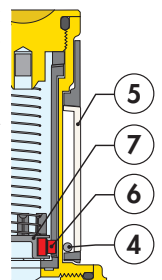

Complete closing and opening of the valve

The valve can be completely closed and opened. A slot on the control stem indicates the valve position. When the control stem is turned fully clockwise (the slot is perpendicular to the axis of the valve), the valve is fully closed (A). When the control stem is turned fully counter-clockwise (the slot is parallel to the axis of the valve), the valve is fully open (B).

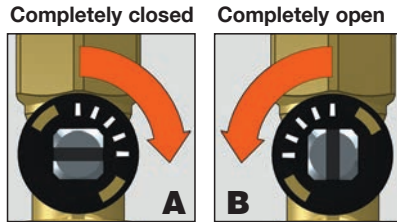

Installation

Install the balancing valve in a location that ensures free access to the flow meter shutoff valve, control stem and flow rate indicator. To ensure accurate flow measurement, straight sections of pipe installed as shown is recommended.

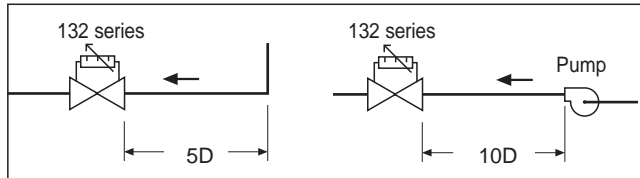

The valve can be installed in any position with respect to the flow direction shown on the valve body. Additionally, the valve can be installed either horizontally or vertically.

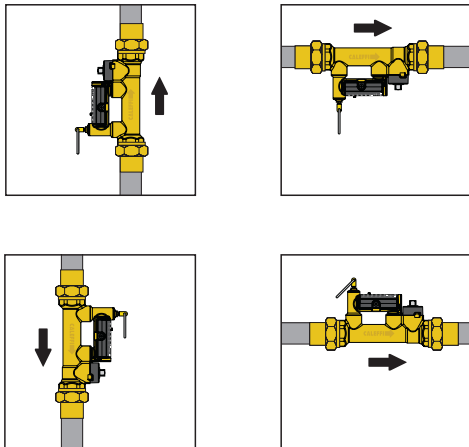

Flow rate adjustment

The flow rate is adjusted as follows:

- With the aid of the flow rate indicator (1), mark the desired flow rate.
- Use the operating ring (2) to open the bypass valve slowly. This allows fluid to flow through the flow meter (3). The bypass valve is automatically closed under normal operating conditions.

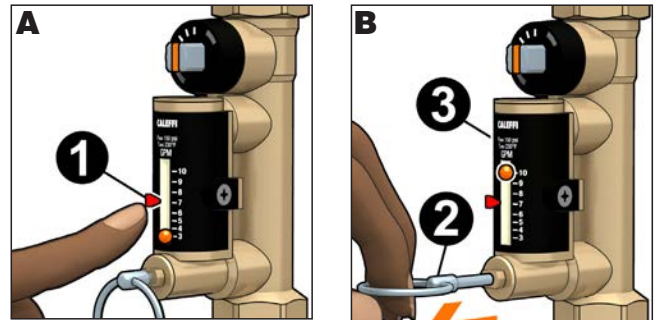

- While holding the bypass valve open, use a wrench to turn the valve control stem (4) to adjust the flow rate slowly. The resulting flow rate is indicated by the metal ball (5) that slides up and down inside a transparent channel (6) marked by a graduated scale in gpm.

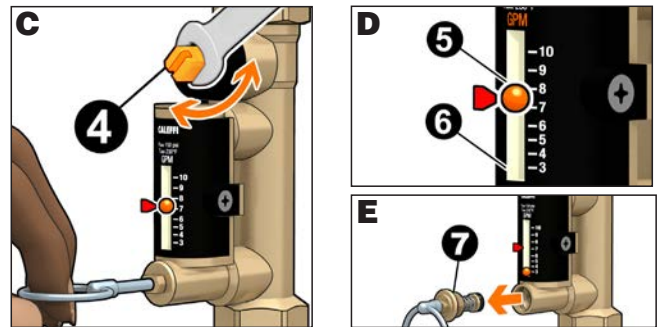

- Once the flow rate is properly adjusted, release the operating ring (2) of the bypass valve. The valve will automatically return to the closed position by means of an internal spring.

- A replacement bypass valve stem (7) with operating ring is available in event it is damaged and inoperable. Order code F19346.

SPECIFICATION SUMMARIES

132 series

Balancing valve with flow meter. Union sweat connections 1/2", 3/4", 1". DZR low-lead brass body (<0.25% Lead content) certified by IAPMO R&T. Stainless steel ball. Chrome-plated brass ball control stem. PTFE ball seal seat. PSU control stem guide. DZR low-lead brass flow meter body and headwork. Stainless steel flow meter bypass valve stem. Stainless steel flow meter springs. PSU flow meter float and indicator cover. EPDM seals. Provided with inlet flow check valve. Water and glycol solutions. Maximum percentage of glycol 50%. Maximum working pressure 150 psi (10 bar). Working temperature range 14 to 230 deg F (-10 to 110°C). Flow rate range unit of measurement gallons per minute (gpm). Accuracy $\pm 10\%$. Control stem angle of rotation 90°. Provide with optional mixed outlet temperature gauge, 30 to 210°F scale, 2 inch diameter.

We reserve the right to change our products and their relevant technical data, contained in this publication, at any time and without prior notice.



Caleffi North America, Inc.
3883 W. Milwaukee Road
Milwaukee, WI 53208
Tel: 414-238-2360 · Fax: 414-238-2366
sales@caleffi.com · www.caleffi.com/usa/en-us
© Copyright 2014 Caleffi North America, Inc.