

BROWNING® Torque Limiters provide overload protection on light drives by supplying a controlled and adjustable slip level.

INSTALLATION

- Clean shaft and Torque Limiter bore to remove any foreign matter.
Make sure the shaft, sheave bore, keys and keyways are free of burrs, paint, etc.
Slide Torque Limiter onto shaft. (While Torque Limiter can be mounted in either direction, mounting with collar away from machine housing permits easier adjustment.)
Insert key and tighten setscrew "A" to the values in Table 1.
- Remove collar, one backing plate, and one friction disc.
Place Torque Limiter sprocket over bronze bearing.
Slip friction disc and backing plate over barrel until they rest against sprocket.
Make sure cap screws B are backed off until points are recessed in collar.
Screw collar on barrel until it is finger-tight against backing plate.

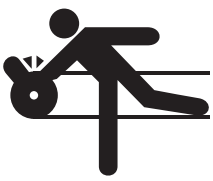

⚠ WARNING
Disconnect power before installation and maintenance. Failure to do so can result in severe injury or death.

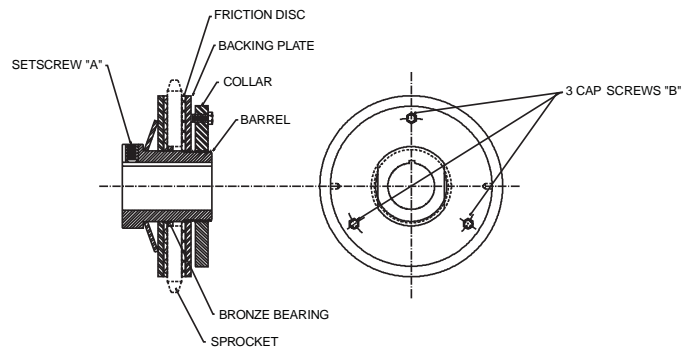

Table 2
Minimum Recommended Number of Teeth and Number of Bearings
Required for Torque Limiters

Table 1

SET SCREW TORQUE (IN-LBS)	
Size	Torque
1/4 - 20	87
5/16 - 18	165
3/8 - 16	250

Torque Limiter	Chain Size											
	35		41		40		50		60		80	
	Min. Teeth	No. Brgs.	Min. Teeth	No. Brgs.	Min. Teeth	No. Brgs.	Min. Teeth	No. Brgs.	Min. Teeth	No. Brgs.	Min. Teeth	No. Brgs.
T25L	25	1	20	1	20	1	—	—	—	—	—	—
T35L	—	—	26	1	26	1	21	2	—	—	—	—
T45L	—	—	—	—	32	1	26	1	22	2	—	—
T55L	—	—	—	—	—	—	32	1	27	2	21	2
T65L	—	—	—	—	—	—	—	—	32	1	24	2

ADJUSTMENT

To adjust the torque limiter to its maximum torque:

- Back off the three cap screws "B" until the points are recessed in the threaded adjusting collar.
- Tighten the collar by hand and then tighten the cap screws until the heads bottom against the collar.
- The torque limiter can be adjusted to a lesser torque by loosening the cap screws and the collar, and then re-tightening the cap screws until the heads bottom against the collar. The torque may be checked in application, or by using a spring scale or other means as shown in the sketch.

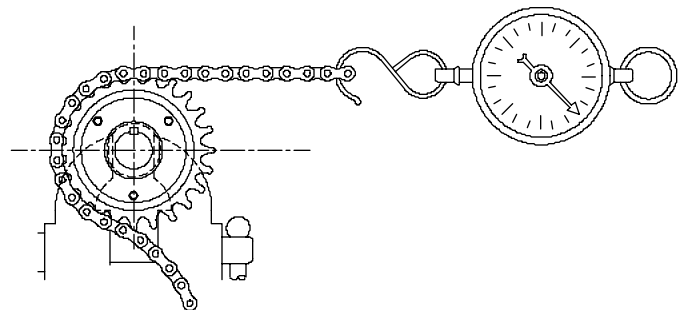
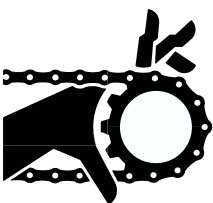

Table 3
Approximate Maximum Torque Ratings in Inch-Pounds

Part Number	With One Spring	With Two Springs
T25L	800	1100
T35L	1800	3000
T45L	2800	4900
T55L	3800	6800
T65L	4800	8800



⚠ WARNING
Operating drives without guards in place can result in severe injury or death.

Have questions? Contact Technical Services at 1-800-626-2093.

