

---

# Installation and operating instructions

---

## Astro 2 circulator models

**File No:** 10.89  
**Date:** AUGUST 05, 2013  
**Supersedes:** 10.89  
**Date:** JUNE 26, 2013

---

---

—

—

—

—

# CONTENTS

---

|            |                                    |   |
|------------|------------------------------------|---|
| <b>1.0</b> | Introduction                       | 4 |
| <b>2.0</b> | Installing                         | 4 |
| <b>2.1</b> | Terminal box                       | 4 |
| <b>2.2</b> | Electrical wiring                  | 5 |
| <b>3.0</b> | Check valve removal (optional)     | 5 |
| <b>4.0</b> | Start up                           | 5 |
| <b>5.0</b> | Installation troubleshooting guide | 6 |
| <b>6.0</b> | Spare parts                        | 7 |

---

---

---

---

**WARNING**



- Prior to installation, read these installation and operating instructions. Installation and operation must comply with local regulations and accepted codes of good practice.

- The use of this product requires experience with and knowledge of the product. Only licensed or trained installers should install this product.
- For supply Connection, use wires acceptable for at least 90°C (194°F).
- Risk of shock: this pump has not been tested for use in swimming pools or marine areas.
- To reduce risk of electric shock: Unplug before servicing, see instructions for proper installation, connect to a properly grounded, grounding type receptacle only.
- For indoor use only.
- Use copper conductors only.
- Do not install with motor above or below pump body.
- Do no submerge.
- Do not run pump dry.

These installation and operating instructions are applicable to the following Astro 2 models.

**ASTRO 2 MODELS**

| MODEL              | ELECTRICAL INPUT           | RATING                     |            |
|--------------------|----------------------------|----------------------------|------------|
| ASTRO 210CI        | 115V, 60HZ<br>Single phase | 200W, 1.72A                |            |
| ASTRO 210SS        |                            | 200W, 1.72A                |            |
| ASTRO 220SSU       |                            | 33W, 0.29A                 |            |
| ASTRO 225SSU       |                            | 83W, 0.69A                 |            |
| ASTRO 225BS ½" SWT |                            | 75W, 0.64A                 |            |
| ASTRO 225BS ¾" SWT |                            | 75W, 0.64A                 |            |
| ASTRO 230SS        |                            | 97W, 0.81A                 |            |
| ASTRO 230CI        |                            | 97W, 0.81A                 |            |
| ASTRO 230CI-R      |                            | 97W, 0.81A                 |            |
| ASTRO 250SS        |                            | 117W, 0.98A                |            |
| ASTRO 250CI        |                            | 117W, 0.98A                |            |
| ASTRO 250CI-R      |                            | 117W, 0.98A                |            |
| ASTRO 280CI        |                            | 218W, 1.9A                 |            |
| ASTRO 280SS        |                            | 218W, 1.9A                 |            |
| ASTRO 290CI        |                            | 218W, 1.9A                 |            |
| ASTRO 290SS        |                            | 218W, 1.9A                 |            |
| ASTRO 280CI 230V   |                            | 230V, 60HZ<br>Single phase | 210W, 0.9A |
| ASTRO 280SS 230V   |                            |                            | 210W, 0.9A |
| ASTRO 286CI        |                            |                            | 370W, 1.6A |
| ASTRO 286SS        |                            |                            | 370W, 1.6A |

**1.0 INTRODUCTION**

You are about to install a pump from the finest multi-speed wet rotor circulator line on the market today. The Armstrong Astro 2 circulators are designed for closed hydronic or potable water systems. Their intended use is for circulating water or glycol solutions. For pumping domestic water use non-ferrous lead free bronze or stainless steel body pump construction.

The Astro 2 operates extremely quietly and is lubricated by the system liquid being pumped by the circulator.

These circulators except Astro 286 are designed to work at temperatures and pressures up to 230°F (110°C) and 150 psi. Astro 286 is designed to work at temperature and pressure upto 150°F (65°C) and 150psi. For fluid temperature upto 185°F (85°C), operating current must not exceed 1.35A. For lead free bronze and stainless steel pumps used in potable water systems, it is recommended that the operating temperature of the fluid be kept as low as possible (i.e. below 150°F/65°C) to avoid precipitation of calcium.

When unpacking the circulator, inspect for any damage that may have occurred during transit. Check for loose, missing or damaged parts.

**2.0 INSTALLING**

We recommend that any soldering be done before the pump is actually installed. This will eliminate the possibility of solder dropping into the pump body.

Thoroughly flush the system out before installing the circulator.

Before Installing, check that the flow direction of the water through the pump body matches the arrow on the circulator body. The circulator is supplied for up discharge installation.

Install the circulator in either the outlet or inlet line to the boiler or hot water heater. It is important to install these circulators with the split between the circulator body and the motor in a vertical position. This ensures efficient operation. See installation examples.

**CORRECT INSTALLATIONS**

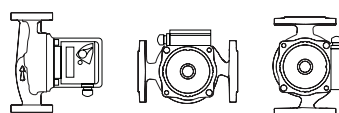

**INCORRECT INSTALLATIONS**

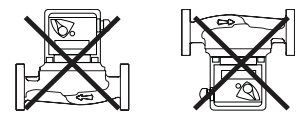

The circulator shaft must always be in a horizontal position. (The piping can be in a horizontal or vertical run.) Isolation valves should be installed on the discharge and suction side of the pump to facilitate service.

## 2.1 TERMINAL BOX

Always install the circulator with the terminal box above or beside the motor. If the terminal box is under the motor as initially mounted, remove the motor mounting screws and rotate the motor to the proper position. (See example.)

Ensure the gasket is intact and seated before evenly retightening the mounting screw to 4.5 - 5.5 lb/ft (6 - 7.5 Nm). To ensure the rotor still spins freely, temporarily remove the plug (located in the middle of the nameplate), insert a flat head screwdriver into the slot in the end of the rotor shaft and turn.

Retighten the plug to 1.5 - 2 lb/ft (2 - 2.7 Nm). Ensure no water leak at all sealing contacts.

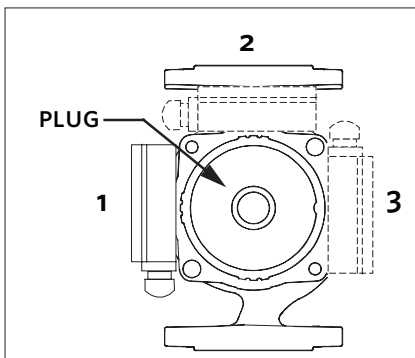

**Do not hang items or articles of clothing on the pump as air must be able to circulate freely through the motor. Do not operate the circulator without the motor plug installed.**

## 2.2 ELECTRICAL WIRING

The electrical wiring must be installed strictly in accordance with national electrical codes, local codes and regulations.

- 1 Electrical installation should be conducted by a qualified electrician.
- 2 Always make sure electric power is disconnected before wiring the circulator.

The motor is designed for 60 Hz, 1 phase, 115 or 230 volt power.

Wire shall be 14 to 16 gauge solid wire or 16 to 18 gauge stranded wire.

To wire, loosen the screw from the terminal box cover and remove the screw and cover.

Insert wires through supplied liquid-seal connector (installed) or included  $\frac{1}{2}$ " NPT adaptor or other strain relief connector (not provided).

Strip  $\frac{3}{16}$ " of insulation from the ends of the three wires to be connected.

To insert the wires into the terminal strip, flip the terminal lever away from the wire opening and press down firmly. Insert the stripped wire into the opening and release the lever. Tug on the wire gently to ensure it is secured.

Connect the hot wire to terminal 'L', the neutral wire to terminal 'N', and the ground wire to terminal  $\oplus$ .

Tighten the terminal box cover.

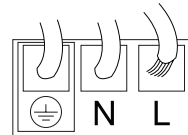

The motor is thermally protected so overload protection is not necessary. All that is required is a fused plug or circuit breaker in the power line. Electrical information can be found on the nameplate of the motor.

## 3.0 CHECK VALVE REMOVAL (OPTIONAL)

Using a pair of needle-nose pliers, grip one of the flat wings of the check valve and gently pull the valve out vertically.

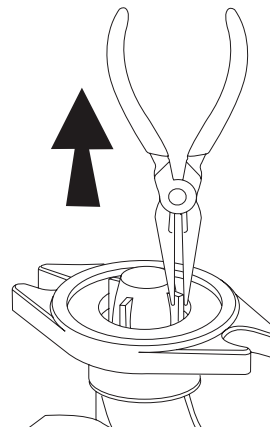

#### 4.0 START UP

These circulators are maintenance free. Self-lubricated by the system fluid, these circulators have no seals to leak or coupling to break.

A proper installation practice recommends to thoroughly flush the system clean of all foreign materials prior to installing the circulator.

Fill the system before starting.

##### Speed setting of Astro 2 3-speed circulators:

(Not applicable for Astro 286)

The speed of these pumps can be adjusted with a 3-speed rotary switch. On speed setting 1, the pump operates at approximately half the performance of the speed setting 3 (maximum speed) and consumes about half the power of full speed operation.

##### WARNING

Never operate the circulator dry as permanent damage may occur. Never shut off the discharge or restrict suction flow while the circulator is operating.

The venting of the rotor chamber may be done automatically. However, to assure proper and faster venting of this circulator, we recommend the manual venting procedure as follows

- 1 Place a container under the back of the circulator to catch any water that may run out.
- 2 Be sure power to the circulator is off at the fuse or circuit breaker.
- 3 Loosen plug on the back of the motor but do not remove.
- 4 Continue until water appears.
- 5 After a sufficient amount of water free of air bubbles has passed, retighten the plug.
- 6 The circulator can now be started.

| LIQUID TEMPERATURE | MINIMUM INLET PRESSURE |
|--------------------|------------------------|
| 150°F (65°C)       | 3.0 ft (0.91 m)        |
| 167°F (75°C)       | 4.4 ft (1.34 m)        |
| 194°F (90°C)       | 9.2 ft (2.8 m)         |
| 230°F (110°C)      | 36.1 ft (11.0 m)       |

#### 5.0 INSTALLATION TROUBLESHOOTING GUIDE

| FAULT                                   | POSSIBLE CAUSE  | REMEDY   |
|---|---|--|
| Noise from radiator                     | Excessive pressure passing the thermostatic valve.  | <ul style="list-style-type: none"> <li>▪ Reduce the speed setting. Flow decreases will reduce system pressure and eliminate the noise.</li> </ul>  |
| The radiator is not giving off any heat | The thermostatic valve is jammed or blocked.  | <ul style="list-style-type: none"> <li>▪ Shut off all other radiators in the system, and set the pump at maximum speed.</li> <li>▪ Once the blockage has been dislodged reopen the radiators and adjust pump to original speed setting.</li> </ul> |
|   | The heating system is not balanced.   | <ul style="list-style-type: none"> <li>▪ Re-assess the system. Fit new commissioning valves on all radiators (may be integrated in the thermostatic valves) to enable an even distribution of the flow.</li> </ul>                                 |
| Pump generates little or no output      | Incorrect discharge direction.  | <ul style="list-style-type: none"> <li>▪ Turn pump 180°</li> </ul>   |
|   | Dirty impeller  | <ul style="list-style-type: none"> <li>▪ Open pump and clean impeller</li> <li><b>NOTE:</b> Close isolation valves if present</li> </ul>   |
|   | Suction port blocked  | <ul style="list-style-type: none"> <li>▪ Open pump and clean housing</li> <li><b>NOTE:</b> Close isolation valves if present</li> </ul>  |
|   | Outlet blocked  | <ul style="list-style-type: none"> <li>▪ Clean isolation valves</li> </ul>   |
|   | Isolation valve closed  | <ul style="list-style-type: none"> <li>▪ Open isolation valves</li> </ul>  |
|   | Dirty strainer  | <ul style="list-style-type: none"> <li>▪ Clean strainer</li> </ul>   |
|   | Air in the pump   | <ul style="list-style-type: none"> <li>▪ Switch off pump and open bleed screw to vent.</li> </ul>  |
| Pump at lowest/medium speed level       | <ul style="list-style-type: none"> <li>▪ Set pump to the next higher speed level.</li> </ul>      |  |
| Pump set point is too low               | <ul style="list-style-type: none"> <li>▪ Increase set point on the pump or controller.</li> </ul> |  |

| FAULT                                       | POSSIBLE CAUSE                                       | REMEDY  |
|---|--|---|
| Pump stopped, no power                      | Power supply interrupted                             | <ul style="list-style-type: none"> <li>▪ Check the power supply. Attach external power control if necessary.</li> </ul>   |
|   | Fuse tripped or circuit breaker opened               | <ul style="list-style-type: none"> <li>▪ Repair short-circuited wire. Repair loose contact.</li> <li>▪ Check for the properly rated fuse.</li> <li>▪ Check pump motor and lead.</li> </ul>  |
| Pump stopped, power supply present          | Thermal switch has actuated                          | <ul style="list-style-type: none"> <li>▪ Reduce ambient temperature.</li> <li>▪ Clean blocked or slow rotating pumps.</li> </ul>  |
|   | Pump does not start                                  | <ul style="list-style-type: none"> <li>▪ Open air vent screw and unlock shaft. Clean pump.</li> <li>▪ Increase speed/set point.</li> <li>▪ Replace pump.</li> </ul>   |
| Noises in system, thermostatic valves/pipes | Pump output too high                                 | <ul style="list-style-type: none"> <li>▪ Reduce speed level.</li> <li>▪ Open bypass/valve.</li> <li>▪ Install circuit balancing valves to adjust flow.</li> <li>▪ Check pump selection/system. Adjust pump. Check system /gauges.</li> <li>▪ Replace pump.</li> </ul>                   |
| Noisy pump                                  | Air in pump  | <ul style="list-style-type: none"> <li>▪ Open bleed screw and vent pump. Vent and top up system with water.</li> <li>▪ Check expansion tank.</li> <li>▪ Install air separator.</li> </ul>   |
|   | Cavitation sounds                                    | <ul style="list-style-type: none"> <li>▪ Increase inlet pressure.</li> <li>▪ Reduce temperature.</li> <li>▪ Throttle back pump.</li> <li>▪ Reduce speed.</li> </ul>   |
|   | Resonance noises                                     | <ul style="list-style-type: none"> <li>▪ Use sound insulation material between the pump and surface to reduce resonance noise. Install expansion joints. Install fixture to change system's natural frequency.</li> <li>▪ Adjusts pump speed.</li> <li>▪ Replace pump/motor.</li> </ul> |
|   | Knocking from foreign bodies in the pump/or on valve | <ul style="list-style-type: none"> <li>▪ Clean impeller.</li> <li>▪ Adjust valve pressure. Adjust valve spring.</li> <li>▪ Turn valve around if installed incorrectly.</li> <li>▪ Replace pump.</li> </ul>  |

## 6.0 SPARE PARTS

| SPARE PART      | ITEM NO.   | APPLICABLE MODELS                                     |
|-----------------|------------|---|
| Check valve 1"  | 810223-104 | Astro 220ssu, Astro 225ssu                            |
| Check valve 1¼" | 810223-105 | Astro 210, Astro 230, Astro 250, Astro 280, Astro 286 |
| Check valve 1½" |            | Astro 290   |

**TORONTO**

23 BERTRAND AVENUE  
TORONTO, ONTARIO  
CANADA  
M1L 2P3  
+1 416 755 2291

**BUFFALO**

93 EAST AVENUE  
NORTH TONAWANDA, NEW YORK  
U.S.A.  
14120-6594  
+1 716 693 8813

**BIRMINGHAM**

HEYWOOD WHARF, MUCKLOW HILL  
HALESOWEN, WEST MIDLANDS  
UNITED KINGDOM  
B62 8DJ  
+44 (0) 8444 145 145

**MANCHESTER**

WENLOCK WAY  
MANCHESTER  
UNITED KINGDOM  
M12 5JL  
+44 (0) 8444 145 145

**BANGALORE**

#59, FIRST FLOOR, 3RD MAIN  
MARGOSA ROAD, MALLESWARAM  
BANGALORE, INDIA  
560 003  
+91 (0) 80 4906 3555

**SHANGHAI**

NO. 1619 HU HANG ROAD, XI DU TOWNSHIP  
FENG XIAN DISTRICT, SHANGHAI  
P.R.C.  
201401  
+86 21 3756 6696

**MAKING  
ENERGY  
MAKE  
SENSE™**