

ULTRA-ZONE™

Forced Air Zone Controls

SUBMITTAL SHEET

Model SBD

Self-Balancing

Smart Bypass Damper

SBD Motor Actuator Specifications:

Operating Range - .1" - 2.4" W.C.
Pressure Sensor - Belimo D3 Dynamic Response
Air Pressure Connectors - 1/4" OD barbs integrated x2
Power - 24vac @ 4.0 volt/amp / 2.0 watt
Wiring - 18 AWG copper
Case - NEMA 3S, IP54
Gear Release - Manual
Maintenance: No Maintenance Required
Listings - UL, CE **Compliance** - ACCA Manual Zr
Pitot Tubes - Included x2
Pressure Tubing - 1/4" ID x 8' (NSF-51) Included x2
Mounting - The SBD can be mounted horizontally, vertically, or in any other position required in the field.

Description of the SBD Motor Actuator:

The Smart Bypass Motor Actuator is a digital differential pressure controller with an integrated PI loop and intelligent software. **The Smart Bypass Damper is the only industry bypass solution that can automatically measure, monitor and maintain the designed operating static pressure of the HVAC system in all modes of operation.**

The Smart Bypass Damper includes all of the accessories needed for field installation.
No measuring instruments are required.

Submittal Specifications:

Furnish and install a Model SBD self-balancing bypass damper manufactured by EWC Controls. Round SBD's are fabricated from 24 gauge galvanized steel. Rolled shells include one female end and one male (crimped) end, with rigid stiffening beads. Includes pressure drop baffling for improved damper authority and linear response. Round SBD's are equipped with a Poron® gasket on the blade.

***Specify model SBD - 8", 10", 12", 14", 16", 18", 20"**

Furnish and install a Model SBD self-balancing bypass damper manufactured by EWC Controls. Rectangular SBD's shall be fabricated from mill finished, extruded 080" aluminum and glass filled nylon bearings. Includes pressure drop baffling for improved damper authority and linear response.

***Specify model SBD - 12x8, 12x10, 12x12, 20x8 20x10, 20x12, etc.**

**Custom sizing is available, call for details.*

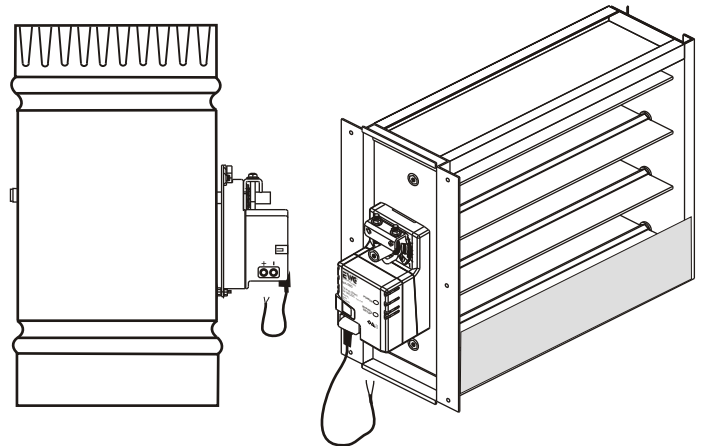

How the Smart Bypass Damper Works:

The Ultra-Zone *Smart Bypass Damper* captures (*with the push of a button*) the total static pressure of the HVAC system during non-zoned mode, and modulates to maintain that same static pressure value, during zoned mode. As individual zone dampers open or close, the HVAC system static pressure will fluctuate. In order to maintain the true static pressure of the HVAC duct system during zoned HVAC operations, a bypass duct with a reliable bypass damper and a smart motor actuator must be installed. **No other bypass damper is easier to setup, than the Ultra-Zone Smart Bypass Damper.**

"SBD" SMART BYPASS DAMPER FIELD WIRING

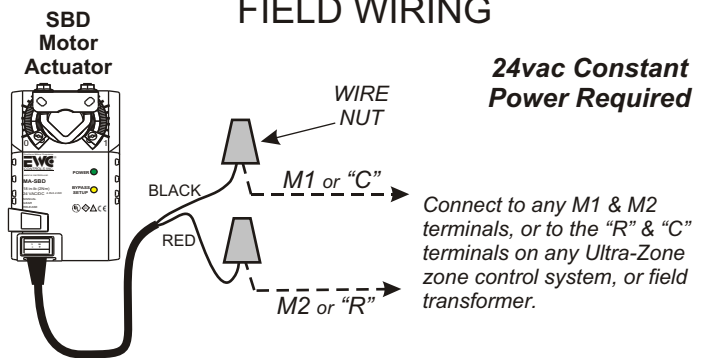

24vac Constant Power Required

Connect to any M1 & M2 terminals, or to the "R" & "C" terminals on any Ultra-Zone zone control system, or field transformer.

Field Wiring = - - - -
 Factory Wiring = ————

SUBMITTAL FORM

SUBMITTED BY: _____
 JOB: _____
 ARCHITECT: _____
 ENGINEER: _____
 CONTRACTOR: _____
 LOCATION: _____

Excellence Without Compromise



385 Hwy. 33
 Englishtown, NJ 07726
 Ph: 800-446-3110
 Fx: 732-446-5362

P/N 090377A0306 REV. B 11.26.14

Copyright © EWC Controls Inc., 2014 All Rights Reserved

SUBMITTAL SHEET

Model SBD Self-Balancing Smart Bypass Damper

Installing the SBD Bypass Damper:

The pitot tubes and reference tubing are included with the SBD. **Make sure you have removed these items from the shipping box before you throw the box away!**

Due to the unique design and the self-balancing feature of the SBD, there is no need to install and setup a separate bypass balancing hand damper.

Mount both pitot tubes within 2 feet of the air handler on the center line of the Supply & Return plenums. *Observe the direction of airflow stamped on the pitot tube mounting plate.* (See the graphic below)

Connect each pitot tube to the SBD barbed fittings using the supplied 1/4" ID plastic tubing. *Keep the plastic tubing as short as possible with no kinks, cuts or nicks.* Connect 24vac power to the SBD.

Upon power-up, the SBD's Power LED will glow solid green. The yellow Bypass Setup button LED will blink, to indicate the SBD is ready and waiting for you to press the by-pass setup button LED and start the setup routine.

Preparing for Smart Bypass Setup:

Before pressing the *Bypass Setup button LED*, the installer must confirm the following:

- (1) Both pitot tubes have been properly installed.
- (2) All zone dampers are in the open position.
- (3) The HVAC system is running at full (CFM) speed.
- (4) The air filter is new or clean.

Proceed to the Smart Bypass Setup Procedure!

Smart Bypass Setup Procedure:

Upon power-up, the Bypass Setup button LED is blinking (*waiting for setup routine*).

1. With a pencil or pen, press the Bypass Setup button LED one time only.

- A. The SBD will close and measure the system's total static pressure.
- B. The SBD will open and measure the system's total static pressure.
- C. The Bypass Setup LED will stop blinking and go out. You are Done!
- D. Repeat the procedure if necessary.
- E. The SBD will now control the system's static pressure in all modes.

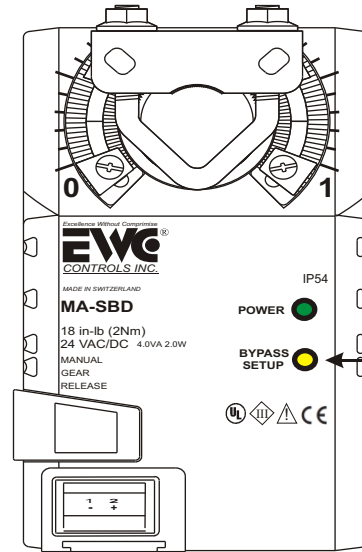

EWC Controls Recommended Bypass Duct Configuration

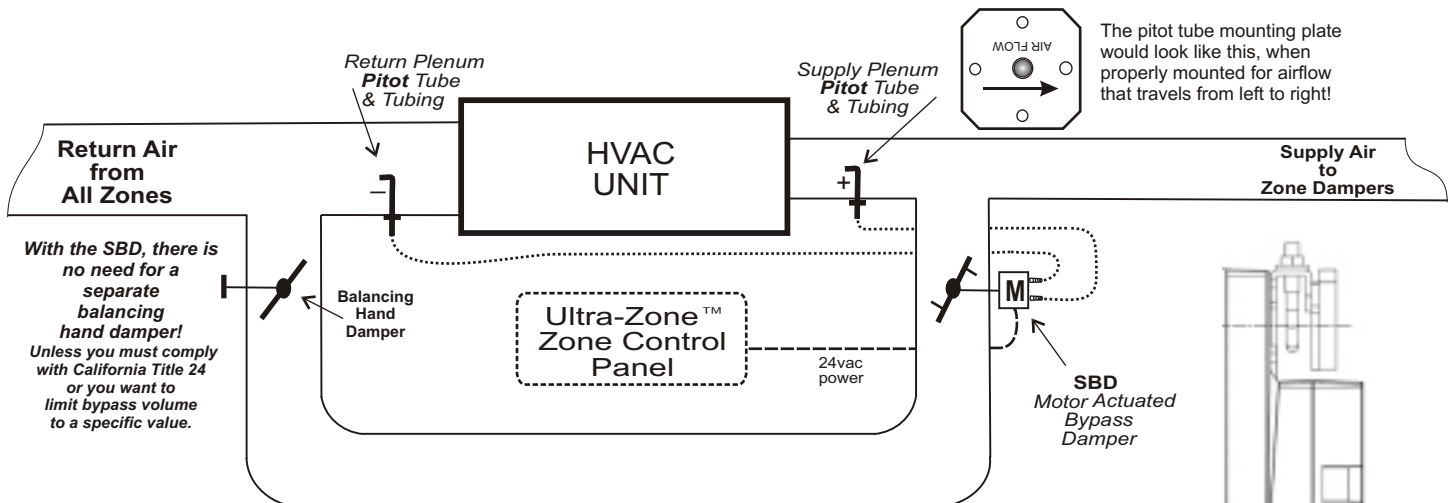

Note: This drawing of the Smart Bypass Damper and bypass duct work is intended to serve as a guide. Your actual duct configuration may differ. Just make sure all components are installed and setup correctly. If required, call EWC Controls Technical Support for assistance.

Connect the pitot/tubing from the Supply duct to the + port. Connect the pitot/tubing from the Return duct to the - port.