

PIPE ATTACHMENTS

CLEVIS HANGER

Figure 100
Figure 100PVC
Figure 100SS

Designed to support non-insulated, stationary lines from above allowing for approximately 1" to 1½" of vertical adjustment after the pipe is in place. The lower nut (not furnished) adjusts the pipe line to the proper elevation, the top nut (not furnished) prevents loosening due to vibration, and must be tightened securely to assure proper hanger performance.

Rated Loads are for up to 650° F (343° C) for carbon steel. Maximum PVC temperature is 140° F (60° C).

Material: Carbon Steel (Also available in Stainless Steel as Figure 100SS).

Compliance: Federal Specification A-A-1192A Type 1, MSS-SP-69 Type 1, BSPSS-BS3974, U.L. and F.M.

Finish: Plain, Painted, Electro-Galvanized, Hot-Dip Galvanized, Plastic Coated, Stainless Steel.

Ordering: Specify figure number, finish and pipe size. For Metric applications specify Figure M100 OR M100SS.

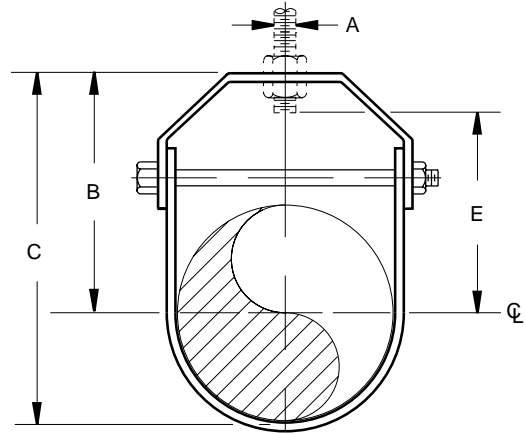

FIGURE 100 – CLEVIS HANGER

PIPE SIZE	MAXIMUM LOAD	A	B	C	ROD TAKE OUT E	WEIGHT EACH
½	610	⅜	2¾	3⅞	1⅞	0.27
15	2714	M10	70	79	48	0.12
¾	610	⅜	2⅞	2¾	1½	0.29
20	2714	M10	54	70	38	0.13
1	610	⅜	3	3¾	2¼	0.33
25	2714	M10	76	95	57	0.15
1¼	610	⅜	3⅞	4	2¼	0.36
32	2714	M10	79	102	57	0.16
1½	610	⅜	3¼	4¼	2⅜	0.42
40	2714	M10	83	108	60	0.19
2	610	⅜	3⅞	4⅞	3⅞	0.52
50	2714	M10	86	117	79	0.24
2½	1130	½	4⅞	5⅞	3⅞	0.61
65	5027	M12	105	143	79	0.28
3	1130	½	5	6⅞	4⅞	0.90
80	5027	M12	127	175	105	0.41
3½	1130	½	4½	6⅞	3⅞	0.99
90	5027	M12	114	168	92	0.45
4	1430	⅝	5⅞	7¾	4⅞	1.40
100	6361	M16	137	197	111	0.64
5	1430	⅝	6	8⅞	5	2.10
125	6361	M16	152	225	127	0.95
6	1940	¾	7	10½	5⅞	3.00
150	8630	M20	178	267	149	1.36
7	2000	¾	7⅞	11¾	6½	5.42
	8897	M20	194	298	165	2.46
8	2000	¾	8½	12¾	6¾	4.50
200	8897	M20	216	324	171	2.04
10	3600	⅞	10	15⅞	8¼	9.10
250	16014	M20	254	391	210	4.13
12	3800	⅞	11⅞	17½	9¼	11.75
300	16904	M20	283	445	235	5.33
14	4200	1	12½	19½	10⅞	14.25
350	18683	M24	318	495	270	6.46
16	4800	1	15	23	13⅞	20.75
400	21352	M24	381	584	333	9.41
18	4800	1	15¾	24¾	13¾	23.00
450	21352	M24	400	629	349	10.43
20	4800	1¼	17⅞	27⅞	15¼	41.50
500	21352	M30	441	695	387	18.82
24	4800	1¼	19⅞	31⅞	17½	50.00
600	21352	M30	498	803	445	22.68
30	6000	1¼	24¾	40¾	21¾	68.08
750	26690	M30	629	1035	552	30.88
36	9500	1½	32⅞	50⅞	30	68.68
900	42260	M36	835	1292	762	31.15