

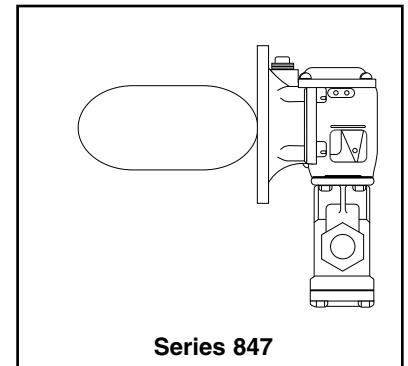

## Series 851, 851-S and 847 Make-Up Water Feeders

**Applications:**  
For receiver tanks in industrial or commercial applications.

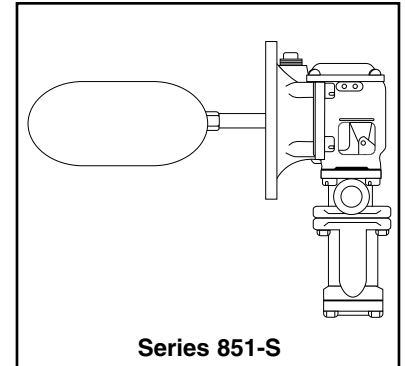
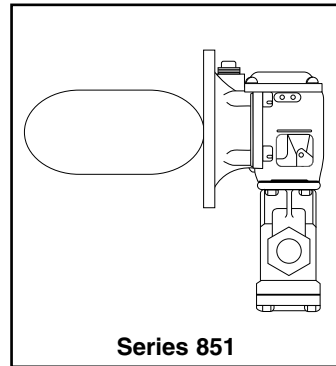

### **WARNING**



- Before using this product read and understand the installation instructions.
- Save the installation instructions and these maintenance and replacement instructions for future reference.



- All work must be performed by qualified personnel trained in the proper application, installation, inspection, and maintenance of HVAC systems in accordance with all applicable codes and ordinances.

Failure to follow this warning could cause property damage, personal injury or death.

# Capacities

## Series 847

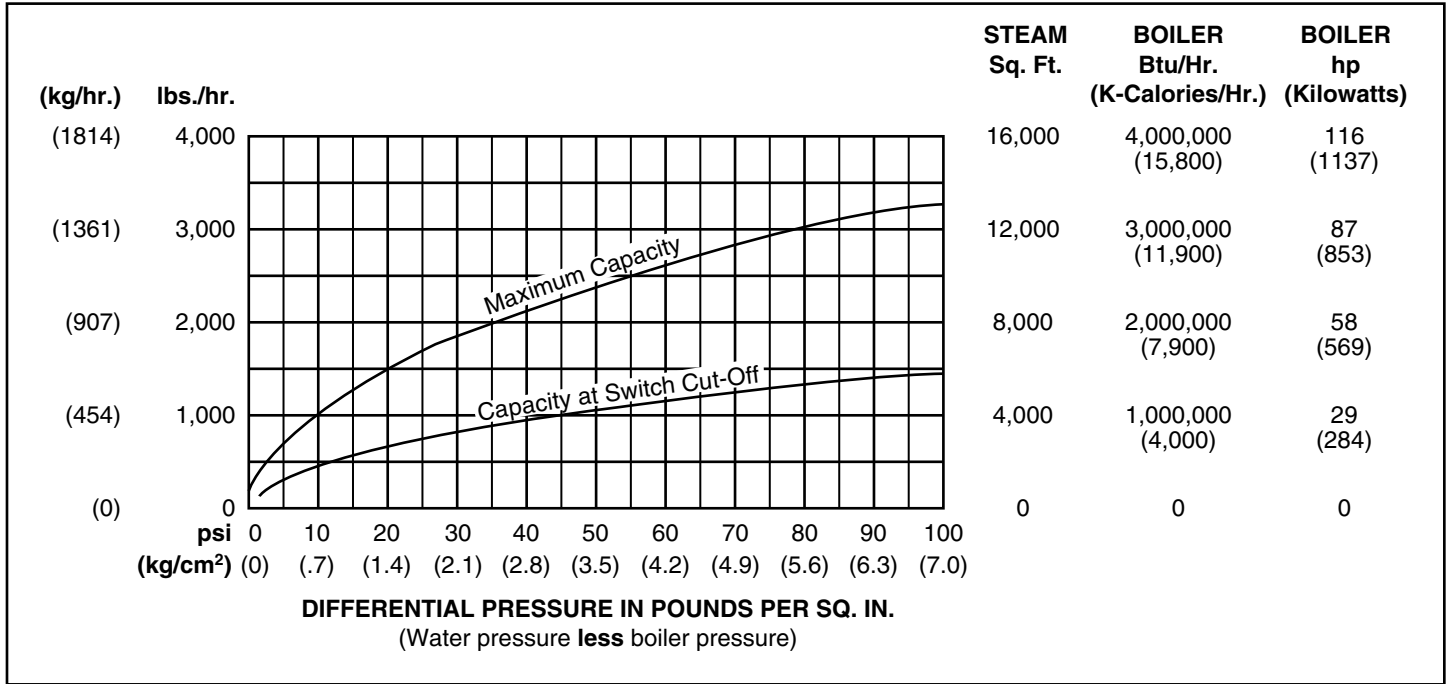

## Series 851

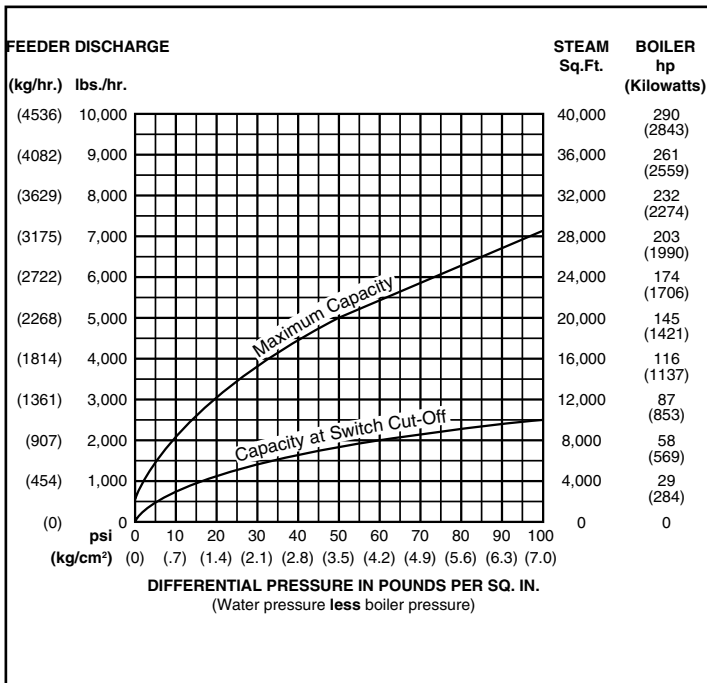

## Series 851-S

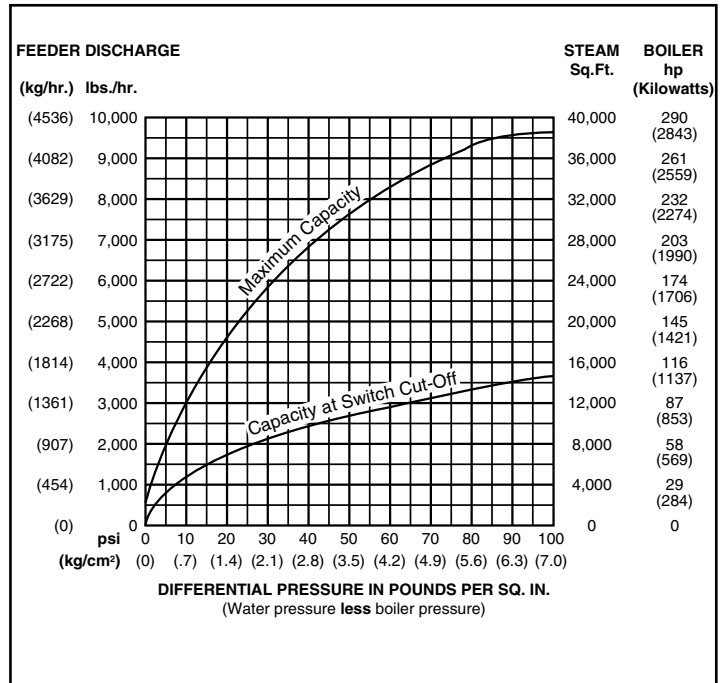

## Operation

Series	Max. Water Supply Pressure, psi	Max. Valve Pressure, psi
851	150	35
851-S	100	35
847	150	25

# INSTALLATION –

## TOOLS NEEDED:

One (1) pipe wrench and one (1) socket wrench.

### STEP 1 - Preparation

Drain the water in the receiving tank to a level which is below the control opening (A). Allow the boiler to cool to 80°F (27°C) and allow the pressure to release to 0 psi (0 bar).

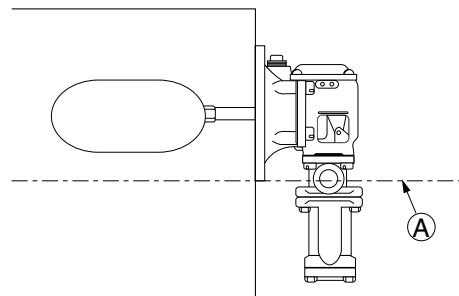

### STEP 2 - Install the Control Unit

Use a socket wrench to secure the feeder (D) to the receiver tank with the six  $\frac{3}{8}$ " - 16 bolts through mounting flange (C) and tighten to 18 ft•lb (24 N•m).

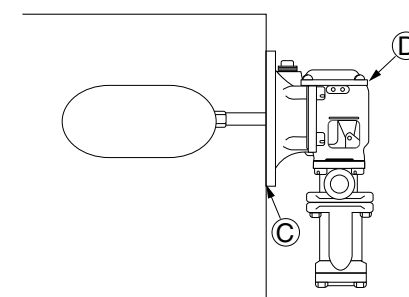

### Mounting Flange Dimensions

#### Series 851, 851-S and 847

#### Dimensions, in. (mm)

O.D.	B.C.	C	D	Float Diameter
6 $\frac{1}{16}$ (170)	5 $\frac{3}{4}$ (146)	6	$\frac{7}{16}$ (11.1)	4 $\frac{3}{4}$ (121)

“C” - number of mounting holes

“D” - size of mounting holes

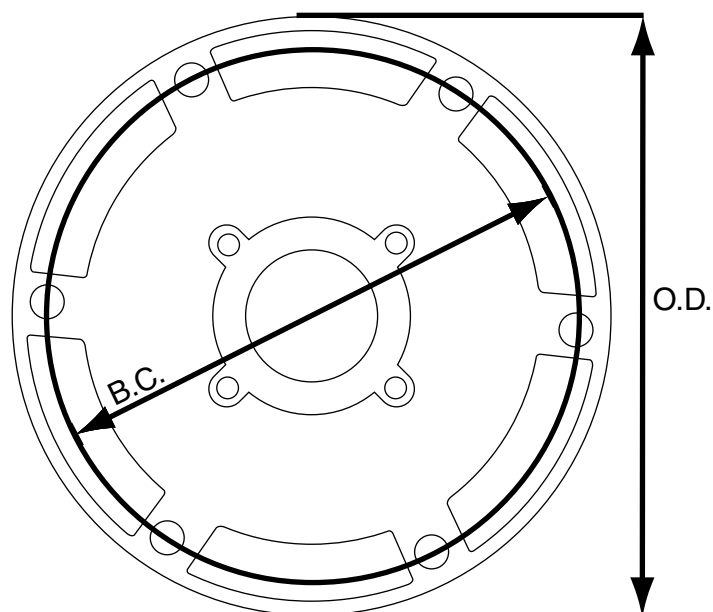

## STEP 3 - Install the Piping

### Piping the Valve on Series 847 and 851

- a. Follow the drawing to the right for piping the valve to boiler and city water supply. When piping the valve remember to leave room for servicing the valve. This will aid in troubleshooting the valve and piping in the future.

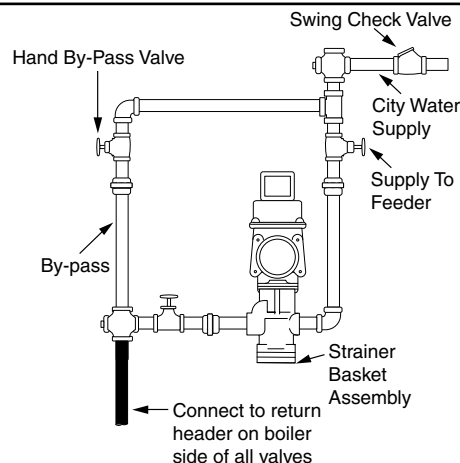

### Piping the Valve on Series 851-S

- a. Follow the drawing to the right for piping the valve to the boiler and city water supply. When piping the valve remember to leave room for servicing the valve. This will aid in troubleshooting the valve and piping in the future.

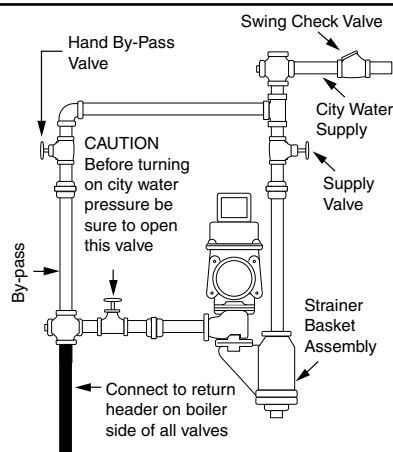

## MAINTENANCE

### SCHEDULE:

- Disassemble and inspect annually. Replace the water feeder if it is worn, corroded, or if components no longer operate properly.
- Disassemble and inspect the strainer screen annually. Thoroughly clean the strainer screen or replace.
- Replace control every 15 years. More frequent replacement may be required when severe conditions exist such as surging water levels and use of water treatment chemicals.
- Remove and inspect cartridge annually. Thoroughly clean by rinsing with clear water or replace.