

Supply Valves

For Supply Valve selection information, please refer to "Selection Guidelines" on page 157.

Model 184

Packless Supply Valve

- For vacuum, steam and water heating systems
- Modulating with dial and pointer
- Brass construction
- Non-rising handle; packless construction
- Angle and straightaway patterns available
- Available in sizes ½" - ¾" NPT
- Opens and closes in less than one turn
- Arrow on handle indicates "ON" and "OFF" direction
- Dial divisions make adjusting valve easy
- Operating pressure:
 - 25" (635mm) Hg vacuum to 125 psig (8.6 bar) for steam service
 - 125 psig (8.6 bar) maximum for water service
- Maximum pressure 125 psig (8.6 bar)

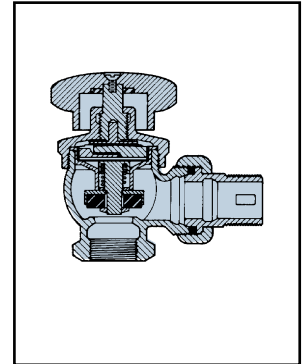

Model 185

Supply Valve

- For two-pipe steam and heating water systems
- Modulating with dial and pointer
- Brass construction
- Non-rising handle with spring packed construction
- Angle and straightaway patterns available
- Available in sizes ½" - 2" NPT
- Opens and closes in less than one turn
- Arrow on handle indicates "ON" and "OFF" direction
- Dial divisions make adjusting valve easy
- Operating pressure:
 - 25" (635mm) Hg vacuum to 150 psig (10.3 bar) for steam service
 - 150 psig (10.3 bar) for water service
- Maximum pressure 150 psig (10.3 bar)

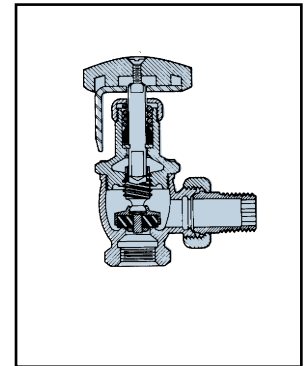

Dimensions

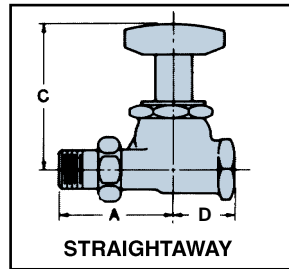
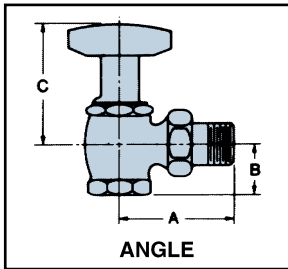

NPT Size in.	Dim. in. (mm)	Model			
		Angle		Straightaway	
		184	185	184B	185B
1/2	A	2 7/8 (73)	2 1/4 (57)	2 5/8 (67)	2 1/4 (57)
	B	1 1/8 (29)	1 1/8 (29)	—	—
	C	2 3/16 (56)	3 1/4 (83)	3 3/16 (87)	3 13/16 (97)
	D	—	—	1 3/8 (35)	1 5/16 (33)
3/4	A	2 5/8 (67)	2 9/16 (65)	2 7/8 (73)	2 5/8 (67)
	B	1 3/16 (30)	1 1/4 (32)	—	—
	C	2 7/8 (73)	3 1/4 (83)	3 5/8 (92)	3 7/8 (98)
	D	—	—	1 5/8 (41)	1 3/16 (40)
1	A	—	3 (76)	—	3 9/16 (90)
	B	—	1 7/16 (37)	—	—
	C	—	3 3/8 (86)	—	4 1/2 (114)
	D	—	—	—	1 7/8 (48)
1 1/4	A	—	3 1/4 (83)	—	3 11/16 (94)
	B	—	1 5/8 (41)	—	—
	C	—	3 5/8 (92)	—	5 1/8 (130)
	D	—	—	—	2 1/16 (52)
1 1/2	A	—	3 3/16 (90)	—	4 1/4 (108)
	B	—	1 7/8 (48)	—	—
	C	—	3 3/4 (95)	—	5 (127)
	D	—	—	—	2 5/16 (59)
2	A	—	4 1/16 (103)	—	—
	B	—	1 1/16 (27)	—	—
	C	—	4 (102)	—	—

Ordering Information

Model Number	Part Number	NPT Size in.	Pattern	Pieces Per Carton	Weight lbs. (kg)
184	405087	1/2	Angle	12	19 (9)
184	405090	3/4	Angle	12	22 (10)
184B	405093	1/2	Straightaway	12	22 (10)
184B	405096	3/4	Straightaway	12	25 (11)

Model Number	Part Number	NPT Size in.	Pattern	Pieces Per Carton	Weight lbs. (kg)
185	405099	1/2	Angle	12	15 (7)
185	405102	3/4	Angle	12	19 (8.6)
185	405105	1	Angle	12	28 (13)
185	405108	1 1/4	Angle	12	37 (17)
185	405111	1 1/2	Angle	12	42 (19)
185	405144	2	Angle	6	35 (16)
185B	405114	1/2	Straightaway	12	22 (10)
185B	405117	3/4	Straightaway	12	22 (10)
185B	405120	1	Straightaway	12	43 (20)
185B	405123	1 1/4	Straightaway	6	25 (12)
185B	405126	1 1/2	Straightaway	6	32 (15)