

PRODUCT SPECIFICATION DRAWING

QUICK SHED™ #QS-E24, QS-E26 & #QS-E30

Water Heater Enclosures (24", 26" & 30" Models)

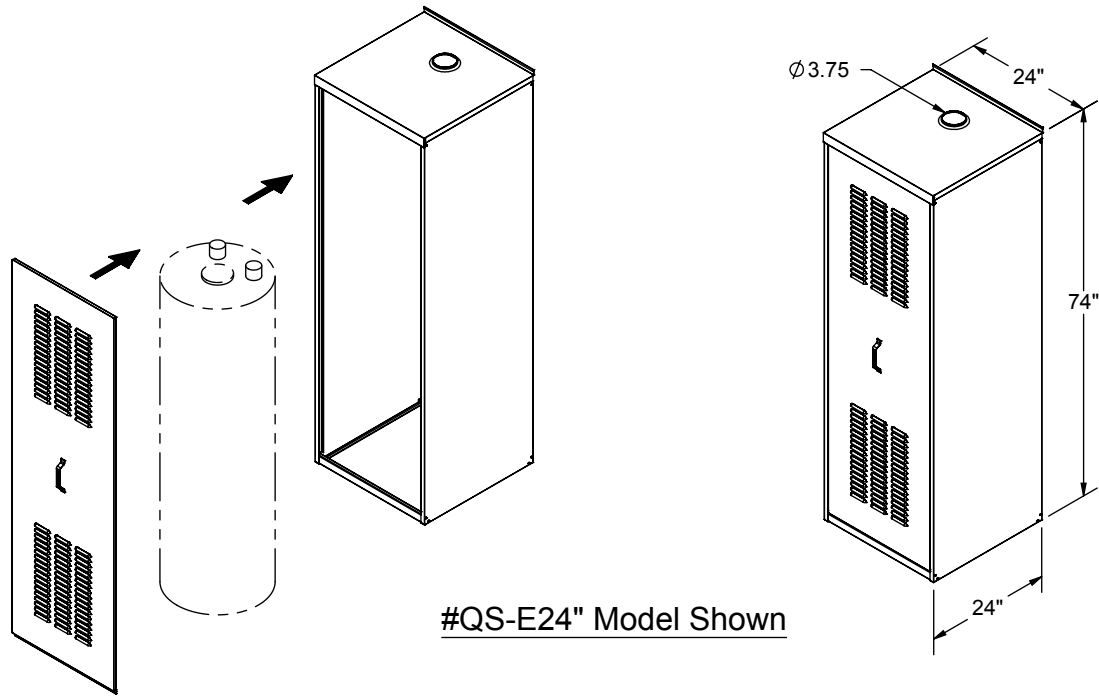

The **HOLDRITE® QUICK SHED™** Water Heater Enclosures are constructed of galvanized steel and provide protection for water heaters installed in outdoor locations. Anchor points at the rear of the enclosure allows for optional attachment to the adjacent building structure.

Product Information:

- Material:
 - Top, Door, Left & Right Side: .018" - .021" Thick, Galvanized CRS
 - Back Brace & Beam: .023" - .026" Thick, Galvanized CRS
 - Handle: 16GA, Galvanized CRS
- Weight (without Packaging & Water Heater):
 - Model #QS-E24 = 39 LBS
 - Model #QS-E26 = 42 LBS
 - Model #QS-E30 = 49 LBS
- Outside dimensions:
 - Model #QS-E24 = 24" x 24" x 74"
 - Model #QS-E26 = 26" x 26" x 74"
 - Model #QS-E30 = 30" x 30" x 74"
- Water Heater Dimensions:
 - QS-E24: Up to 40 gallons or 22" diameter by 68" high
 - QS-E26: Up to 40 gallons or 24" diameter by 68" high
 - QS-E30: Up to 80 gallons or 27" diameter by 68" high

Product Submittal	
Job Name:	
Date:	
Part Number:	Qty:
Architect / Owner:	
Contractor:	
Notes:	

.....HUBBARD ENTERPRISES.....
HOLDRITE®
 "Converting Makeshift Methods into Engineered Solutions"™