

PRODUCT SPECIFICATION DRAWING

QUICK STAND™ #50-SWHP-M

Suspended Water Heater Platform

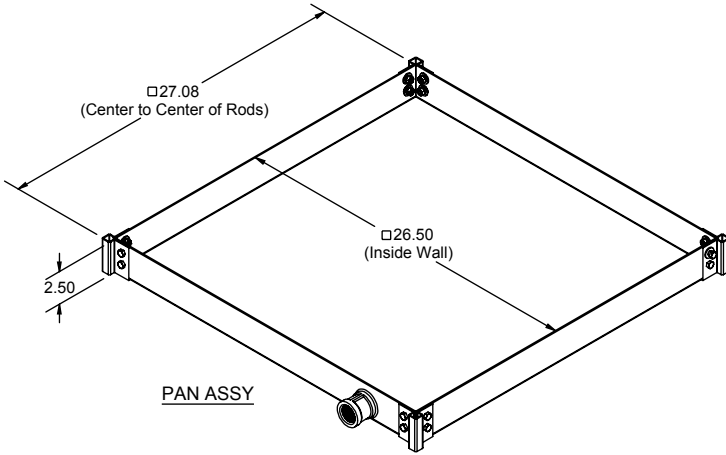

ALL DIMENSIONS IN INCHES

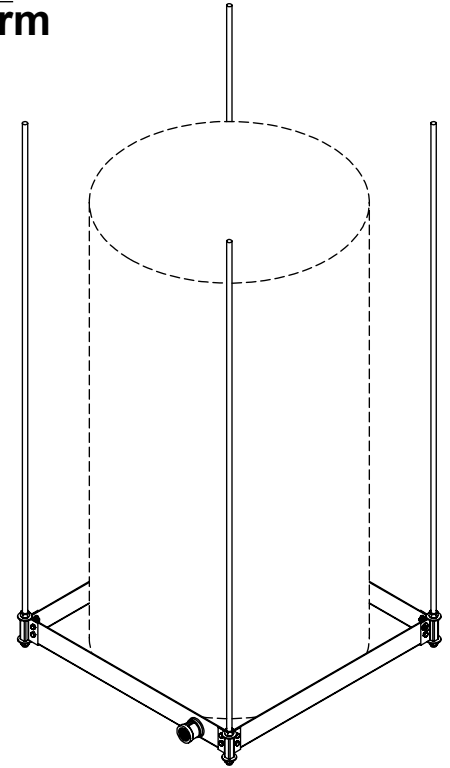

FULLY ASSEMBLED

The Suspended Water Heater Platform is engineered to support water heaters up to 50 U.S. gallons (up to 600 pounds total weight). This time and labor savings tool is designed for the Professional Contractor. Design features requested by plumbers are incorporated into a professional platform that can be suspended with all thread rod.

Product Information:

- Material:
 Pan: 12 gage CRS, galvanized
 Corner Brackets: 14 gage CRS, galvanized
- Wide platform allows water heaters up to 26-1/2" diameter
- Watertight corners and welded 1" steel drain body eliminate need for additional drain pan
- Static load rating 600 pounds with 2X safety factor (depending on structural anchorage)
- Galvanized steel construction
- Suspends with user supplied 3/8" or 1/2" threaded rod and hardware
- Four corner attachment points allows for seismic/sway bracing connection
- Patent pending

Product Submittal	
Job Name:	
Date:	
Part Number:	Qty:
Architect / Owner:	
Contractor:	
Notes:	

