

GENERAL DESCRIPTION

The model PRD pressure regulating damper is a single blade rectangular barometric damper with a counter balanced weighted arm. The PRD is an economical way of bypassing excess air when zone dampers close. Damper adjustment is done by moving the weight up and down the arm and by off-setting the arm. See Page 2 for details.

The PRD is installed in the By-Pass ductwork to regulate the excess air pressure. The damper can be mounted to relieve the pressure by returning the air back to the return air duct (See Figure 1) or by dumping it into a non-critical conditioned area.

The PRD is an ideal By-Pass solution for any Constant Speed or Variable Speed system up to 5 ton capacity.

Bypass Damper Assembly

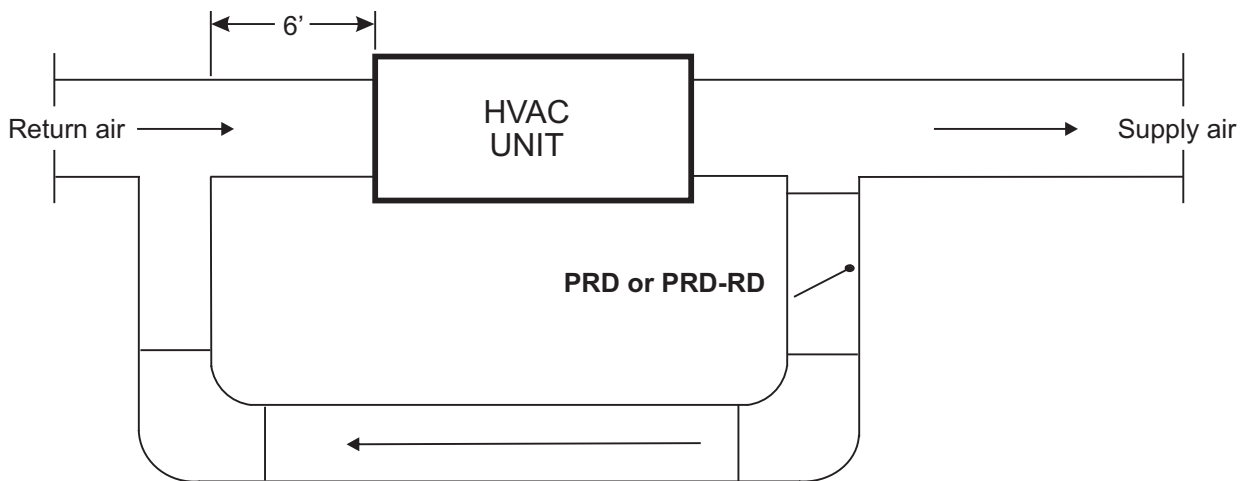

FIGURE 1

Model numbers, sizes available and amount of CFM bypass

MODEL #	SIZE W x H	BYPASS CFM*
PRD 12 x 8	12" x 8"	1,000 CFM
PRD 12 x 10	12" x 10"	1,200 CFM
PRD 12 x 12	12" x 12"	1,400 CFM
PRD 20 x 8	20" x 8"	1,600 CFM
PRD 20 x 10	20" x 10"	2,000 CFM
PRD 20 x 12	20" x 12"	3,000 CFM

*By-Pass CFM is determined at 0.3" w.c. Friction per 100' of ductwork

BAROMETRIC BY-PASS SET-UP PROCEDURE

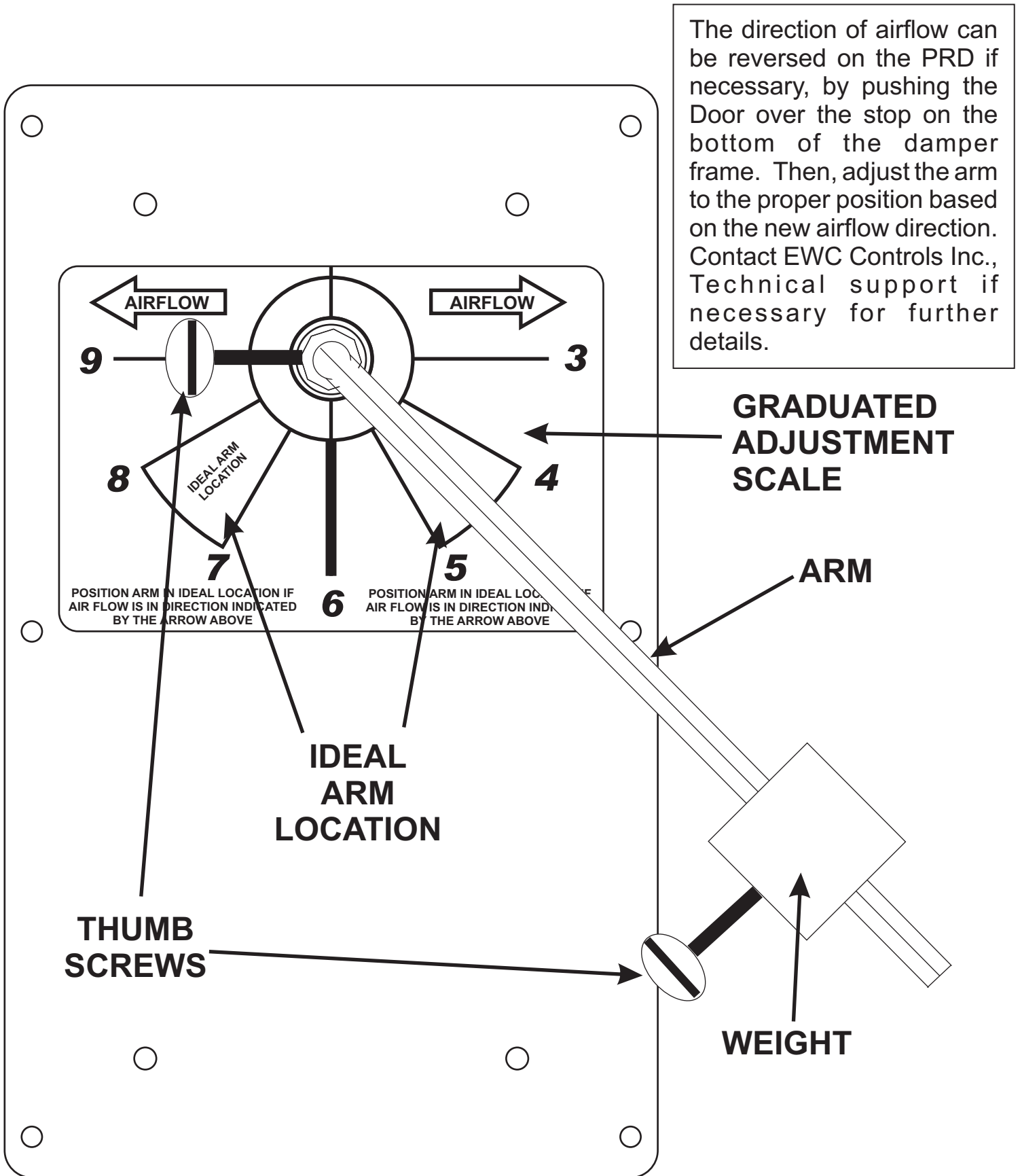

FIGURE 2

BAROMETRIC BY-PASS DAMPER

ASSEMBLY OF PRD & PRD-RD BY-PASS DAMPER

- 1 - INSTALL BY-PASS DAMPER PER INSTRUCTIONS ON PAGE 2.
- 2 - SLIDE LOCKING-COLLAR OVER DAMPER SHAFT.
- 3 - INSERT HEX ARM INTO DAMPER SHAFT.
- 4 - ALIGN LOCKING-COLLAR THUMB SCREW WITH ONE OF THE 4 HOLES ON THE DAMPER SHAFT WHILE HOLDING ARM AT THE DESIRED ANGLE.
- 5 - TIGHTEN THUMB SCREW TO SECURE HEX ARM IN PLACE.
- 6 - POSITION WEIGHT ON HEX ARM AND TIGHTEN THUMB SCREW TO SECURE IN PLACE.
- 7 - REFER TO PAGE 2 FOR SET-UP PROCEDURE.

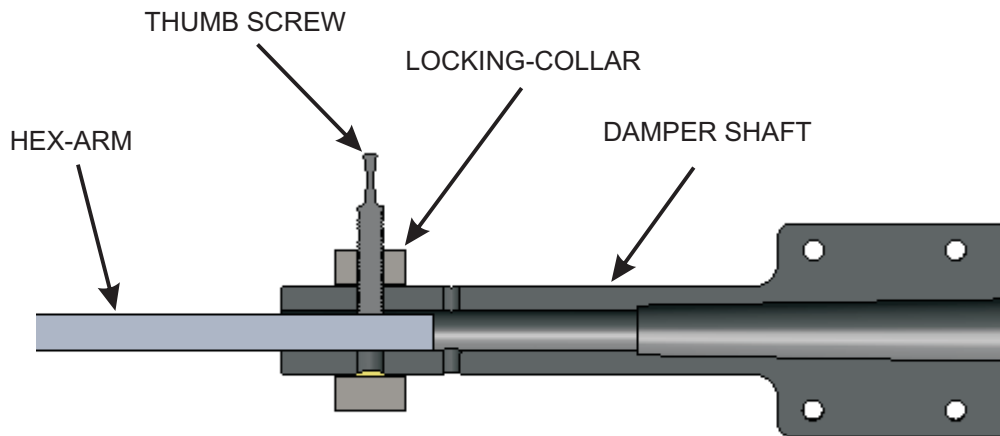

FIGURE 3 -- CUT AWAY VIEW OF ASSEMBLY

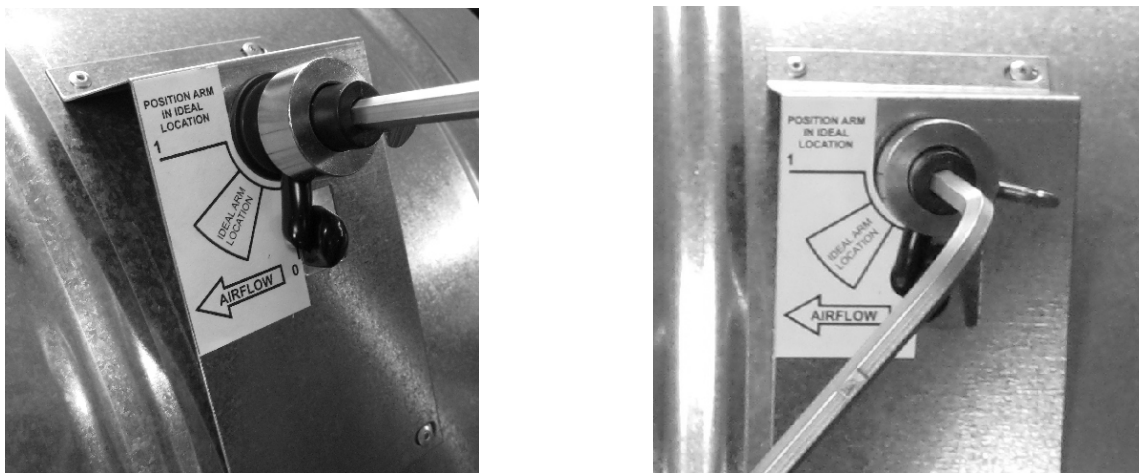

FIGURE 4 -- CLOSE-UP VIEWS OF ASSEMBLY