

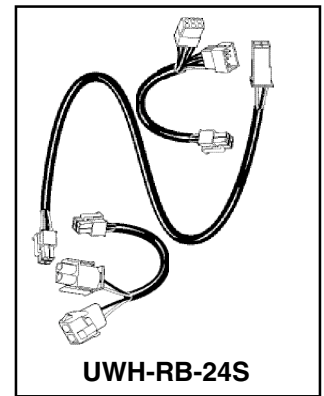

UWH-RB-24 Universal Wiring Harness

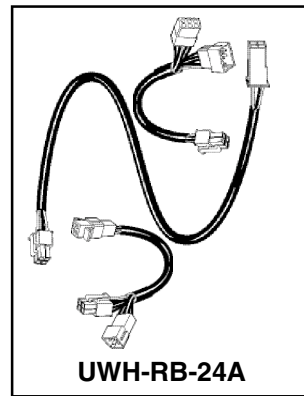

The Universal Wiring Harness includes a cable connector and three 'Y' harnesses, which allow an RB-24 LWCO to be connected to most residential hot water boilers having a 24 volt burner circuit.

WARNING



- Before using this product read and understand instructions.

- Save these instructions for future reference.



- All work must be performed by qualified personnel trained in the proper application, installation, and maintenance of plumbing, steam, hot water, and electrical equipment and/or systems in accordance with all applicable codes and ordinances.

- To prevent electrical shock, turn off the electrical power before making electrical connections.

- This low water cut-off must be installed in series with all other limit and operating controls installed on the boiler. After installation, check for proper operation of all of the limit and operating controls, before leaving the site.



- We recommend that secondary (redundant) Low Water Cut-Off controls be installed on all boilers with heat input greater than 400,000 BTU/hour. At least two controls should be connected in series with the burner control circuit to provide safety redundancy protection should the boiler experience a low water condition. Moreover, at each annual outage, the low water cut-offs should be dismantled, inspected, cleaned, and checked for proper calibration and performance.



Failure to follow this warning could cause property damage, personal injury or death.

Engineered for life

RB-24 SPECIFICATIONS

Temperature:

Storage: -40°F to 120°F (-40°C to 49°C)

Ambient: 32°F to 120°F (0°C to 49°C)

Humidity: 85% (non-condensing)

Maximum Water Pressure: 160 psi (11.2 kg/cm²)

Maximum Water Temperature: 250°F (121°C)

Electrical Ratings

Voltage	Power Consumption	Switching Capacity
24 VAC	2.5 VA	2A at 24 VAC

Enclosure Rating: NEMA 1 General Purpose

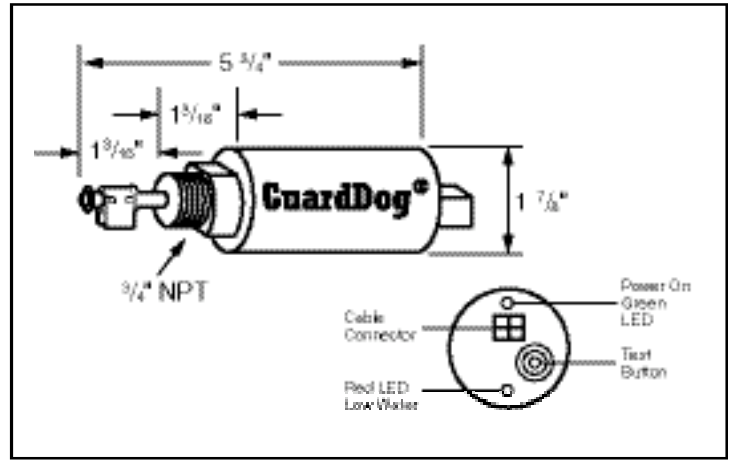





IMPORTANT: Do not use Model RB-24 on steam boilers.

IMPORTANT: Do not use on millivolt systems.

STEP 1 - Determine Where to Install the Low Water Cut-Off

Follow the installation instructions included with the RB-24 LWCO, determine where to locate the control. Please note that the connector cable included the UWH wiring harnesses is 5ft long which will determine where the RB-24 control is located in the boiler or piping.

STEP 2 - Electrical Wiring Options

 WARNING	
	<ul style="list-style-type: none"> To prevent electrical shock, turn off the electrical power before making electrical connections.
	<ul style="list-style-type: none"> This low water cut-off must be installed in series with all other limit and operating controls installed on the boiler. After installation, check for proper operation of all of the limit and operating controls, before leaving the site.
	<p>Failure to follow this warning could cause property damage, personal injury or death.</p>

IMPORTANT: Before making any wiring connections to the boiler with the connector or 'Y' harnesses, **YOU MUST** wire the boiler per boiler manufacturer's recommendations and verify operation.

IMPORTANT: Universal wiring harness adaptors are now available for use with systems having modular plug-on burner controllers and vent dampers (sold separately).

The UWH-RB-24A is for use on hot water boilers that have a vent damper.

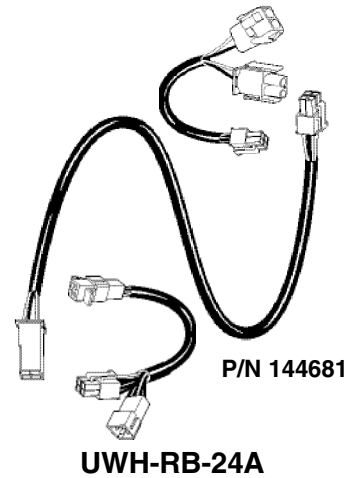

The UWH-RB-24S is for use on hot water boilers that have a transformer plug connection on the aquastat.

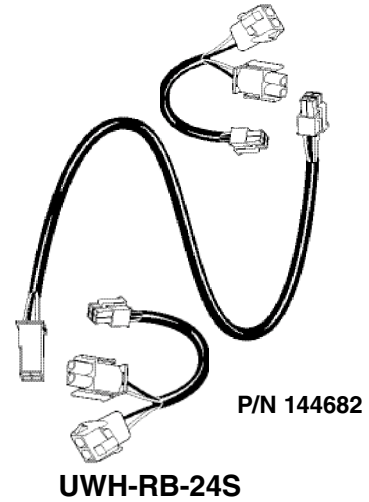

The UWH-RB-24L is for use on hot water boilers that have a control panel connection.



Option 1 - Damper 'Y' Harness

NOTE

This 'Y' Harness can only be used with vent dampers with 6-pin connectors.

- A.** Remove connector of damper wiring harness from connector on control.
- B.** Plug connector of UWH-RB-24 damper 'Y' harness to connector on control.
- C.** Plug connector of UWH-RB-24 damper 'Y' harness to connector of damper wiring harness.

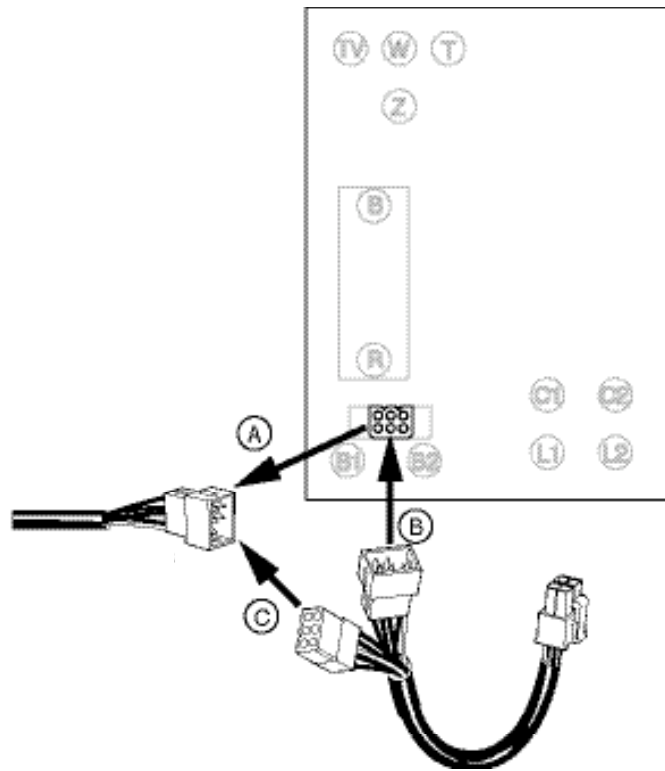

Option 2 - Transformer 'Y' Harness with GREEN Color Tubing

- A.** Remove connector of boiler wiring harness from Aquastat transformer connector.
- B.** Plug connector of boiler wiring harness to connector of 'Y' harness with GREEN color tubing.
- C.** Plug connector of 'Y' harness with GREEN color tubing to Aquastat transformer connector.

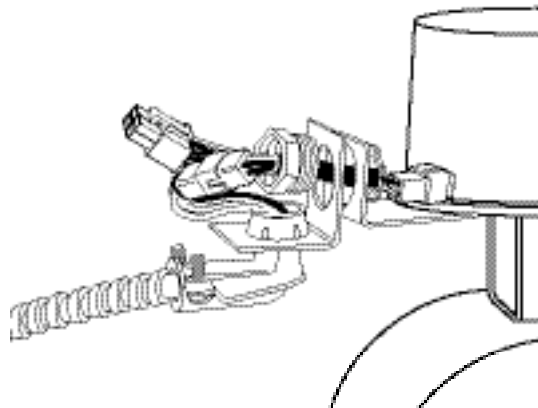

Option 3 - Transformer 'Y' Harness with GREEN Color Tubing

- A.** Remove connector of boiler wiring harness from Aquastat transformer connector.
- B.** Plug connector of boiler wiring harness to connector of 'Y' harness with GREEN color tubing.
- C.** Plug connector of 'Y' harness with GREEN color tubing to Aquastat transformer connector.

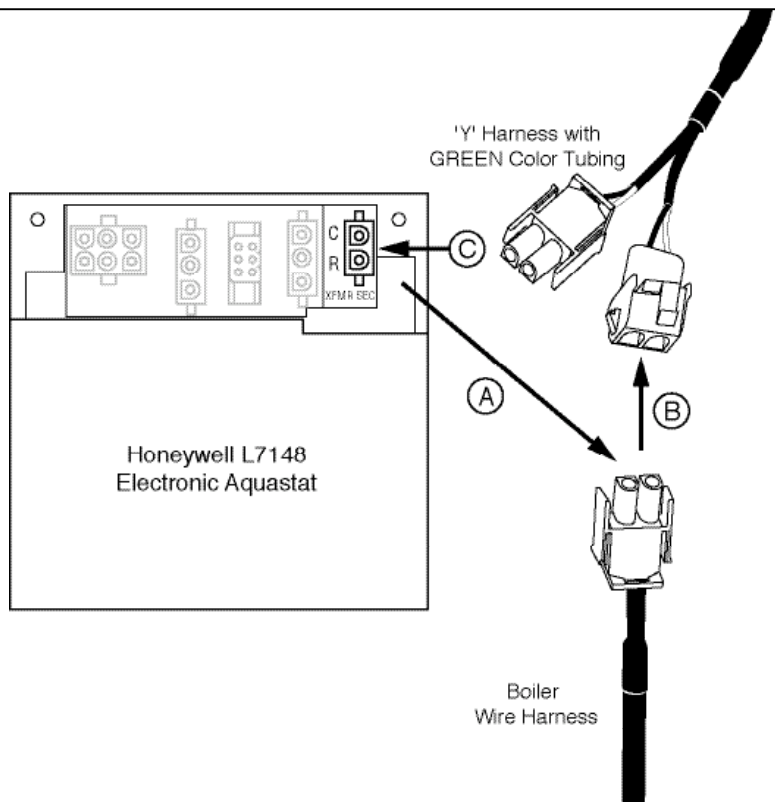

Option 4 - Transformer 'Y' Harness with BLUE Color Tubing

- A.** Remove connector of boiler wiring harness from boiler control transformer connector.
- B.** Plug connector of boiler wiring harness to connector of 'Y' harness with BLUE color tubing.
- C.** Plug connector of 'Y' harness with BLUE color tubing to boiler control transformer connector.

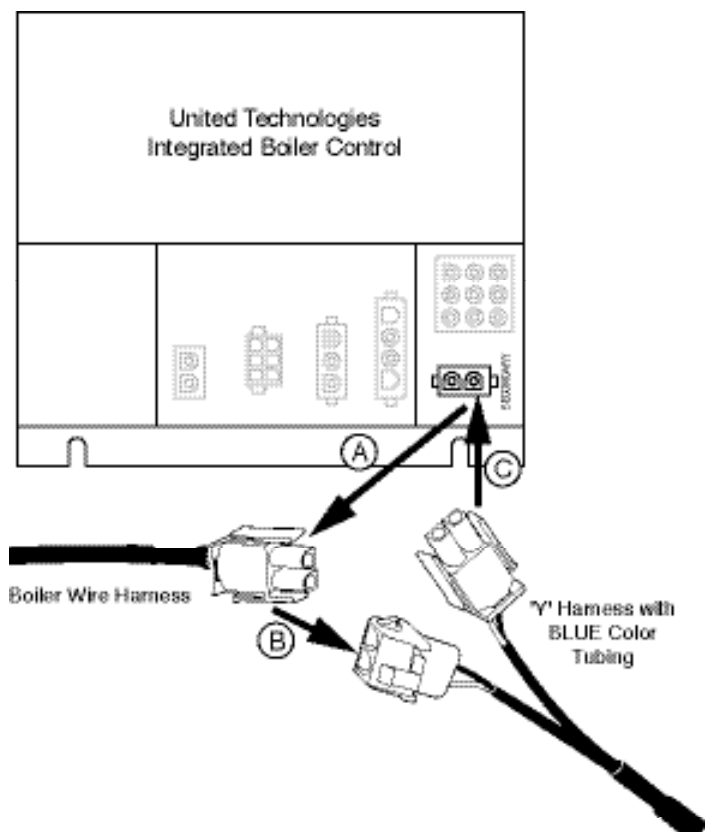

STEP 4 - Connection to RB-24

- a. Plug connector of cable into connector of RB-24.
- b. Plug connector of 'Y' harness into connector of cable.

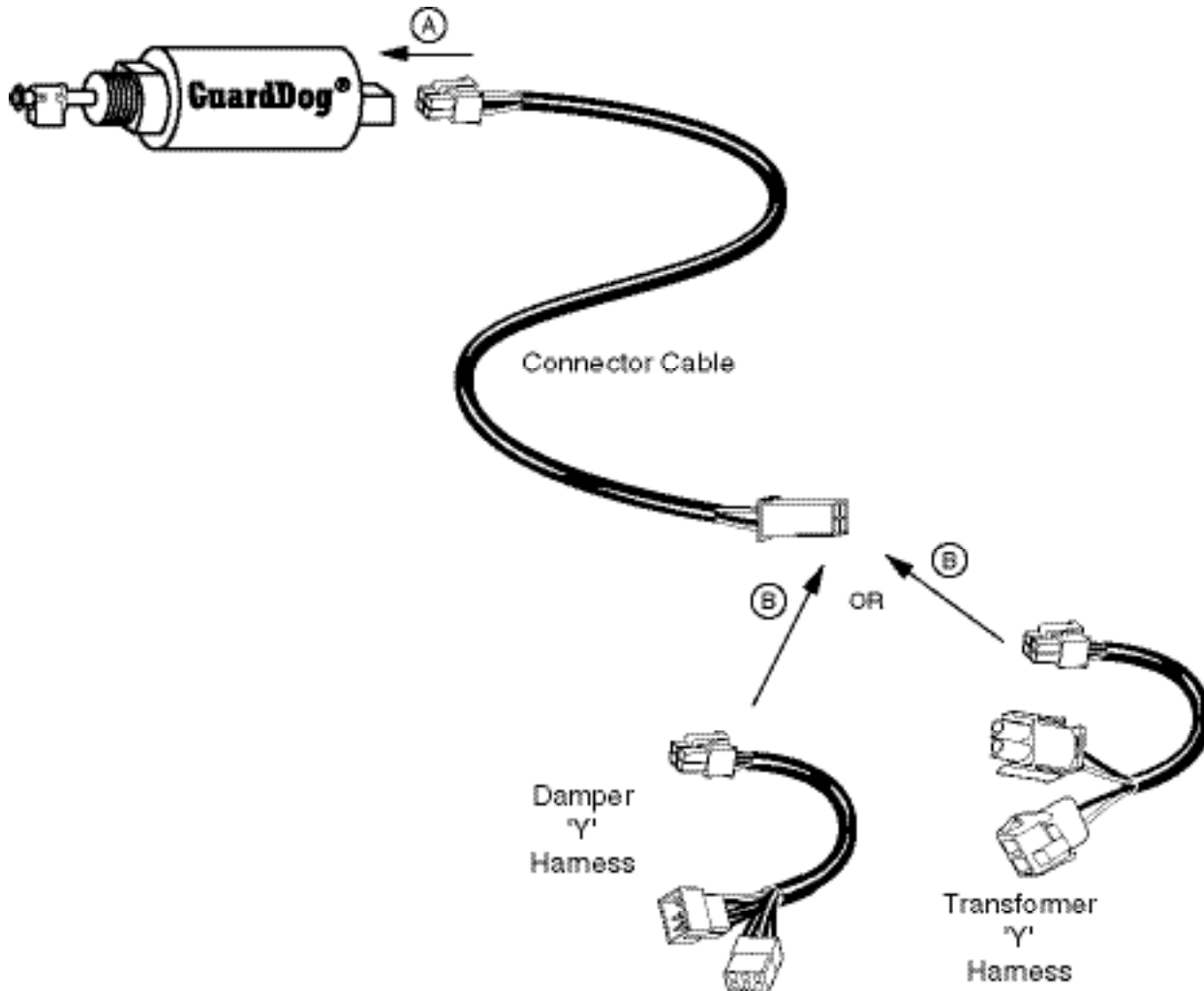

RB-24E-L Connector with Gray Color Tubing for Control Panel Connection

- a. Remove jumper plug from plug-in connector on control panel.
- b. Plug connector of wiring harness into plug-in Connector on control panel.

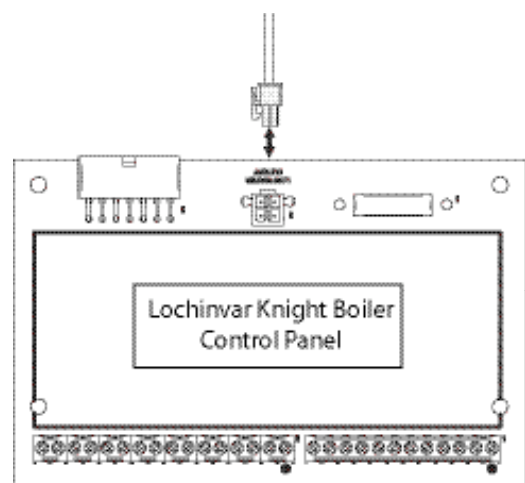

STEP 5 - Testing

- a. **Before filling the system**, turn on the electric power to the boiler. The low water cut-off's green "Power On" LED should be illuminated. With the room thermostat set on "heat," confirm that the burner **will not** operate without water in the system. The low water cut-off's red LED should be illuminated.

NOTE: The burner will come on briefly (1 second or less) and then shut off to verify proper operation.

- b. Fill the system with water. When water is just above the probe, the low water cut-off's red LED should turn off.
- c. Check and confirm that the boiler's thermostat, burner and safety limits are operating properly after filling system and before leaving the site.
- d. Check the threaded connection of the RB-24 low water cut-off for leakage. Tighten, if necessary.

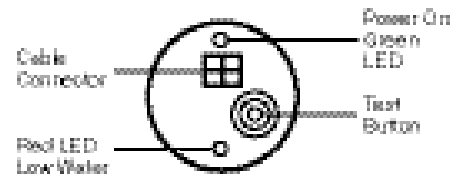
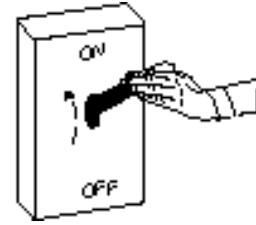

Testing Control Using "Test Button"

Pressing the "Test Button" interrupts the probe circuit which simulates water off the probe.

- Press and hold "test button" while burner is running.
- The burner should turn OFF and red light turn ON if burner is wired correctly.
- Release the test button and the red light should turn off and the boiler should turn on provided that the boiler water is in contact with the probe.

INSTALLATION COMPLETE



TROUBLESHOOTING:

If control fails to operate, follow the following diagnostic checks.

1. Check to be sure that the water level in the boiler is at or above the level of the probe.
2. Re-check all wiring to ensure proper connections as specified in boiler manufacturers wiring diagrams.
3. Check to ensure that Teflon tape has not been used on the threaded connection of the probe to the boiler.
4. Check the quality of the boiler to ensure adequate conductance.

Boiler Does Not Turn Off (when water is below probe)

- Turn off boiler and check boiler wiring connections.
- Turn off boiler, drain boiler and remove control to check if the tip of the probe is touching a metal surface.

Boiler Does Not Turn ON

- Make sure water is above the level of the probe.
- Make sure probe is installed in a location where an air pocket cannot develop.
- Check boiler wiring connections.

Boiler Does Not Turn ON and RB-24 Red LED blinking

- Problem is wrong transformer 'Y' harness.
- Turn off boiler and install correct transformer 'Y' harness.

MAINTENANCE

SCHEDULE:

- Test the low water cut-off annually or more frequently.
- Remove and inspect the self-cleaning probe every 5 years.
- Replace probe every 10 years.
- Replace the low water cut-off every 15 years.

NOTE

Clean probe by wiping with non-abrasive cloth and rinsing with clean water. DO NOT use sharp instruments to remove any accumulations of rust or scale.

CAUTION

Replace Probe if:

- Teflon® insulator is cracked or worn.
- Probe is loose.

Failure to follow this caution could cause property damage, personal injury or death.

