

Sloan SOLIS® Single Button Flush and Dual-Flush Flushometer

Battery powered, sensor activated unit for exposed closet and urinal flushometers.

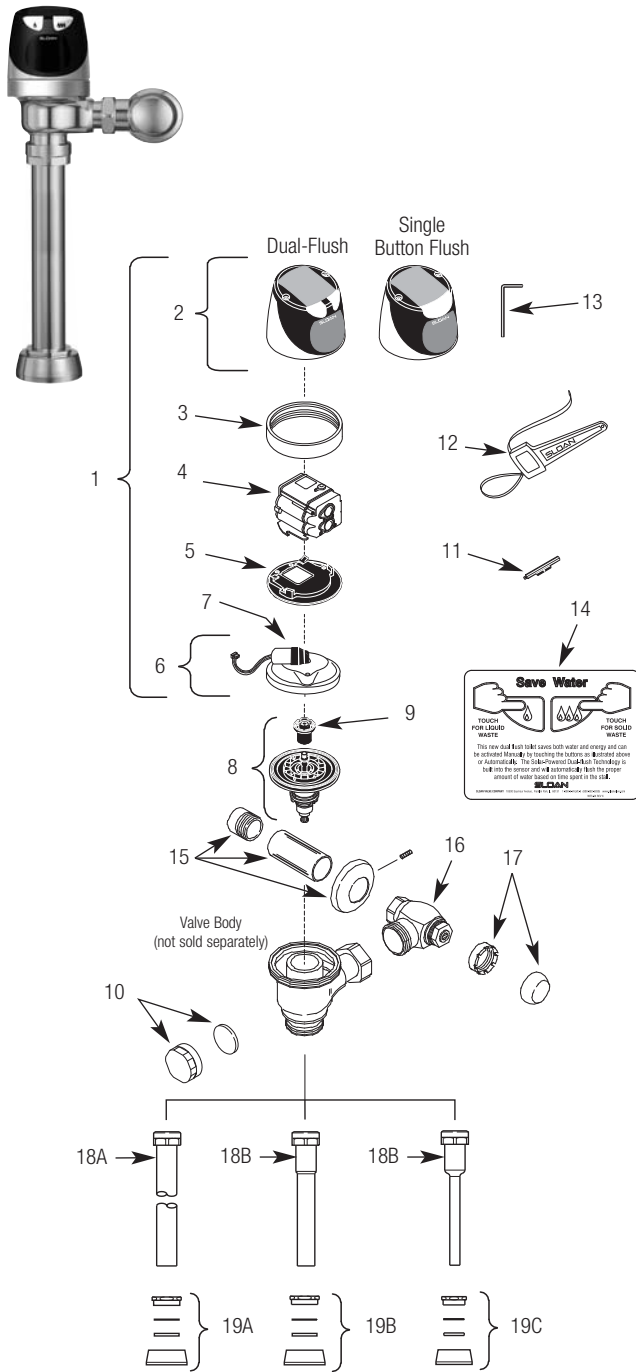

PARTS LIST

Item No.	Code No.	Part No.	Description
Items Included with RESS Retrofit and Complete Sloan SOLIS® Valves			
1.	0325300	EBV-304-A	Cover/Sensor/Assembly - Water Closet (Single Button Flush)
	0325320	EBV-320-A	Cover/Sensor/Assembly (Zurn) - Water Closet (Single Button Flush)
	0372024	WES-24-A	Cover/Sensor/Assembly - Water Closet (Dual-Flush)
	0372028	WES-28-A	Cover/Sensor/Assembly (Zurn) - Water Closet (Dual-Flush)
	0325301	EBV-306-A	Cover/Sensor/Assembly - Urinal (Single Button Flush)
	0325321	EBV-321-A	Cover/Sensor/Assembly (Zurn) - Urinal (Single Button Flush)
2.	0325311	EBV-311-A	Cover Assembly - (Dual-Flush)
	0325309	EBV-309-A	Cover Assembly - (Single Button Flush)
3.	0325804	EBV-14	Locking Ring
	3325524	EBV-31-A	Locking Ring - for Zurn valves
4.	0325312	EBV-312-A-C	Sensor Assembly - Water Closet (Single Button Flush)
	0325313	EBV-312-A-U	Sensor Assembly - Urinal (Single Button Flush)
	0372038	WES-33-A	Sensor Assembly - Water Closet (Dual-Flush)
5.	0325171	EBV-134	Cover Rest Plate
6.	3325456	EBV-145-A	Inside Cover Assembly (includes solenoid)
7.	3325453	EBV-136-A	Solenoid
8.	SEE CHART NEXT PAGE		Flex Tube Diaphragm Assembly
9.	SEE CHART NEXT PAGE		Flush Volume Regulator
10.	3325814	EBV-1017-A	Handle Cap
11.	0325107	EBV-91	Range Adjustment Tool
12.	0305823	EBV-22	Strap Wrench
13.	0325159	EBV-137	7/64" Hex Wrench
14.	—	WES-27	English Plate (Dual-Flush only)
	—	WES-29	Spanish Plate (Dual-Flush only)
Items Included with Complete Sloan SOLIS® Valves Only			
15.	3308782	H-633-AA	1" (25 mm) Sweat Solder Kit
	3308788	H-636-AA	3/4" (19 mm) Sweat Solder Kit
16.	3308386	H-700-A	1" (25 mm) Bak-Chek® Control Stop
	3308384	H-700-A	3/4" (19 mm) Bak-Chek® Control Stop
17.	3308772	H-1010-A	Vandal Resistant Stop Cap
18A.	3393007	V-600-AA	1-1/2" (38 mm) x 9" (229 mm) Vacuum Breaker (Model 8110)
18B.	3393006	V-600-AA	1-1/4" (32 mm) x 9" (229 mm) Vacuum Breaker (Model 8180)
18C.	3393004	V-600-AA	3/4" (19 mm) x 9" (229 mm) Vacuum Breaker (Model 8186)
19A.	0306146	F-5-AT	1-1/2" Spud Coupling Assembly (Models 8110, 8115 & 8116)
19B.	0306140	F-5-AU	1-1/4" Spud Coupling Assembly (Model 8180)
19C.	0306125	F-5-AW	3/4" Spud Coupling Assembly (Model 8186)

Sloan SOLIS® Single Button Flush and Dual-Flush Flushometer

OPERATION

1. A continuous, INVISIBLE light beam is emitted from the Sloan SOLIS® Sensor.
2. As the user enters the beam's effective range, 22 to 42 inches (559 mm to 1067 mm) for closet installations and 15 to 30 inches (381 mm to 762 mm) for urinal installations, the beam is reflected into the Scanner Window to activate the Output Circuit. Once activated, the Output Circuit continues in a "hold" mode for as long as the user remains within the effective range of the sensor. For Dual-Flush models, if the user stays longer than 65 seconds, a full flush will automatically initiate when the user leaves. For Single Flush models, once the user steps away, a full flush will automatically initiate.
3. For a Dual-Flush models, once a user is detected, if the user leaves in 65 seconds or less, a reduced flush will automatically initiate. The circuit automatically resets and is ready for the next user. For a Single Flush models, when the user steps away, this initiates a full flush. The circuit automatically resets and is ready for the next user.

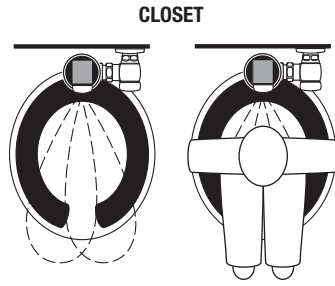

CLOSET

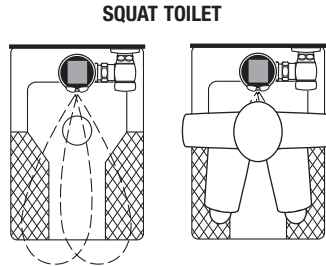

SQUAT TOILET

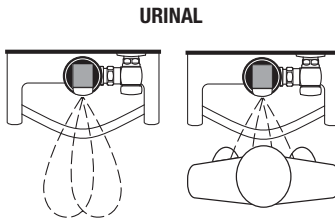

URINAL

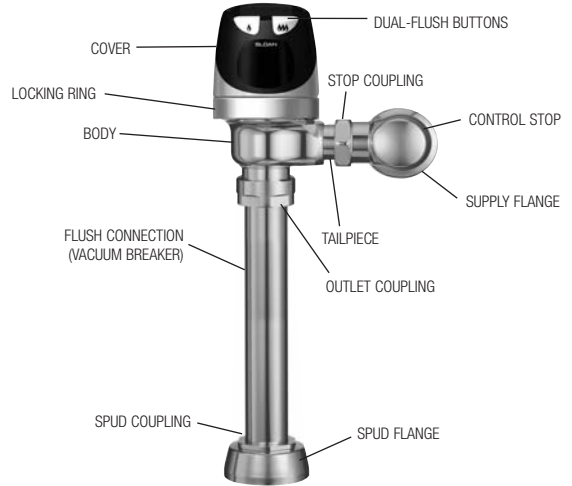

FLEX TUBE DIAPHRAGM ASSEMBLY



Sloan SOLIS® Valve Models Feature Sloan's Exclusive Flex Tube Diaphragm™ for the ultimate in valve performance, reliability and chloramines resistance.

FLEX TUBE DIAPHRAGM KIT SELECTION GUIDE

Code No.	Part No.	Description	Regulator Color
3325001	EBV-1020-A	1.6 gpf/6.0 Lpf Closet	GREEN
3325003	EBV-1023-A	0.5 gpf/1.9 Lpf Urinal	GREEN

The EBV-1020-A Kit is supplied with multiple Flush Volume Regulators. The installer must use the correct Regulator when installing the kit.

REGULATORS

The flush volume of the flex tube diaphragm kit is controlled by the regulator. Regulators are identified by color. Some flex tube diaphragm kits are supplied with multiple regulators. The installer must make sure the proper regulator is used when installing the flex tube diaphragm kit.

REGULATOR (SOLD 6 PER PACKAGE)

Code No.	Part No.	Description	Regulator Color
5325122	EBV-95	Urinal-0.5 gpf/1.9 Lpf	GREEN
5325122	EBV-95	Closet-1.6 gpf/6.0 Lpf	GREEN

FLEX TUBE DIAPHRAGM ASSEMBLY

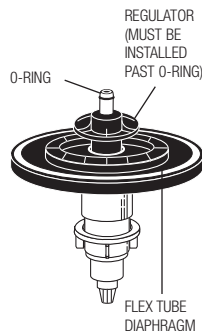

Optima Plus Valve Models Feature Sloan's Exclusive Flex Tube Diaphragm™ for the ultimate in valve performance, reliability and Chloramine resistance.

Sloan SOLIS® Single Button Flush and Dual-Flush Flushometer

BATTERY REPLACEMENT

When required, replace batteries with four (4) Alkaline AA-Size Batteries.

Note: Water does not have to be turned off to replace Batteries.

Loosen the two (2) Screws on top of unit. Remove the complete Cover Assembly. Lift the Sensor Module from its Plate. Unplug the Electrical Connector from Battery Compartment Cover. Loosen the Retaining Screw on Battery Compartment Cover and remove Battery Compartment Cover. Install four (4) Alkaline AA-Size Batteries **exactly** as illustrated.

Install Battery Compartment Cover and secure with Retaining Screw. Make certain that Battery Compartment Cover is fully compressed against Gasket to provide a seal; **Do not** overtighten. Plug the Electrical Connector into the Battery Compartment Cover. Reinstall the Sensor Module onto the Plate. Reinstall the complete Cover Assembly onto the Plate. Tighten the two (2) Screws on top of the unit.

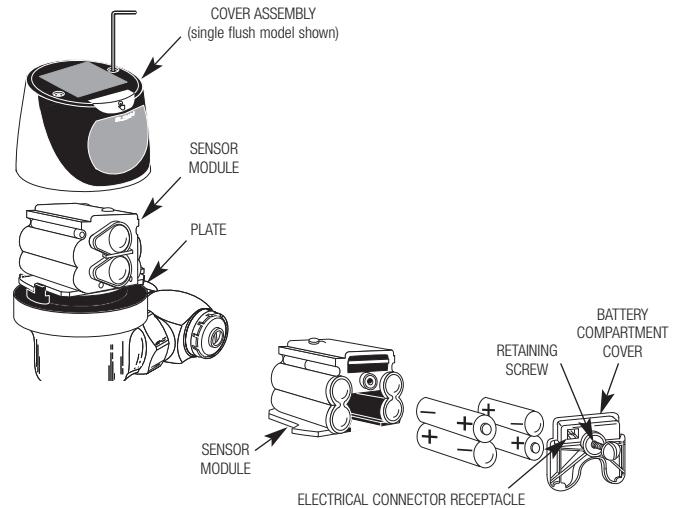

RANGE ADJUSTMENT (ADJUST ONLY IF NECESSARY)

The Sloan SOLIS® has a factory set sensing range:

Water Closet Models - 22" to 42" (559 mm to 1067 mm)

Urinal Models - 15" to 30" (381 mm to 762 mm)

The Factory setting should be satisfactory for most installations.

If the range is too short (i.e., not picking up users) or too long (i.e., picking up opposite wall or stall door) the range can be adjusted.

Note: Water does not have to be turned off to adjust range.

Loosen the two Screws on top of the unit and remove cover. Remove the Rubber Plug from top of Electronic Sensor Module to uncover the Potentiometer.

Important: Adjust in small increments only! Range Potentiometer Adjustment Screw rotates only 3/4 of a turn; DO NOT over-rotate.

When range adjustment is satisfactory, replace the Rubber Plug. Reinstall Cover and tighten the two Screws on top of the unit.

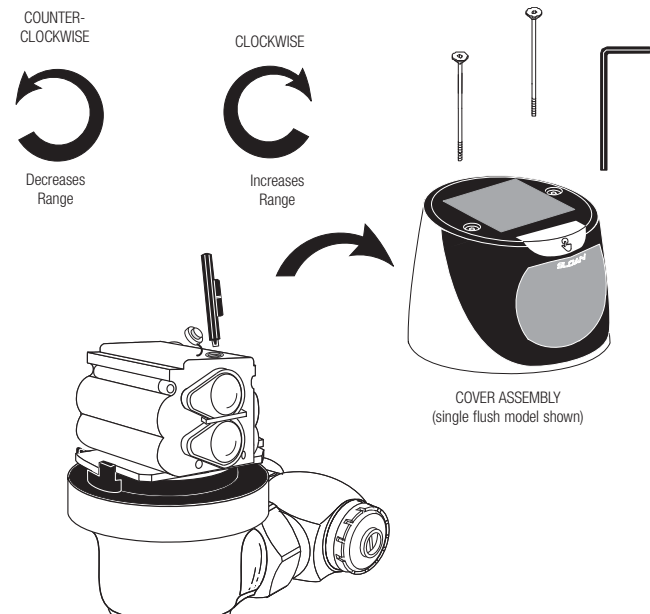

RANGE ADJUSTMENT PROCEDURE

For the first ten (10) minutes of operation, a Visible Light flashes in the Sensing Window of the Sloan SOLIS® Flushometer when a user is detected. This Visible Light feature can be reactivated after ten (10) minutes by opening and closing the Battery Compartment Door.

Check the range by stepping toward the unit until the Light flashes, indicating the Sensor's maximum detection limit. Adjust the Range Potentiometer Screw located on top of the Sensor Module a few degrees **CLOCKWISE** to increase the range or a few degrees **COUNTERCLOCKWISE** to decrease the range. Repeat this adjustment until the desired range is achieved.

Always Determine the Sensing Range with Metal Cover and Lens Window On Top of the Unit.

Important: Adjust in small increments only! Range Potentiometer Adjustment Screw rotates only 3/4 of a turn; DO NOT over-rotate.

When range adjustment is satisfactory, replace the Rubber Plug. Reinstall Cover and tighten the two Screws on top of the unit.

RECOMMENDED WALL PLATE LOCATIONS

Centered over Flushometer

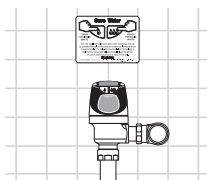

On stall door



Sloan SOLIS® Single Button Flush and Dual-Flush Flushometer

TROUBLESHOOTING GUIDE

1. Sensor Flashes Continuously Only When User Steps Within Range.

- A. Unit in Start-Up mode; no problem. This feature is active for the first ten (10) minutes of operation.

2. Valve Does Not Flush; Sensor Not Picking Up User.

- A. Range too short; increase the range.

3. Valve Does Not Flush; Sensor Picking Up Opposite Wall or Surface, or Only Flushes When Someone Walks By. Light Flashes Continuously for First 10 Minutes Even with No One in Front of the Sensor.

- A. Range too long; shorten range.

4. Valve Does Not Flush Even After Adjustment.

- A. Range Adjustment Potentiometer set at full "max" or full "min" setting. Readjust Potentiometer away from full "max" or "min" setting.
- B. Batteries completely used up; replace batteries.
- C. Problem with Electronic Sensor Module; replace Electronic Sensor Module.

5. Unit Flashes 4 Quick Times When User Steps Within Range.

- A. Batteries low; replace batteries.

6. Valve Does Not Shut Off.

- A. Bypass Orifice in Diaphragm is clogged with dirt or debris, or Bypass is clogged by an invisible gelatinous film due to "over-treated" water. Remove Flex Tube Diaphragm and wash under running water.

Note: Size of Orifice in the Bypass is of utmost importance for the proper metering of water by the valve. DO NOT ENLARGE OR DAMAGE THIS ORIFICE. Replace Flex Tube Diaphragm if cleaning does not correct the problem.

- B. Dirt or debris fouling Stem or Flex Tube Diaphragm. Remove Flex Tube Diaphragm and wash under running water.
- C. O-ring on Stem of Flex Tube Diaphragm is damaged or worn. Replace O-ring if necessary.
- D. Problem with Electronic Sensor Module; replace Sensor Module.

7. Not Enough Water to Fixture.

- A. Wrong Flush Volume Regulator installed in Flex Tube Diaphragm Kit. Install the correct Regulator (see Step 7 of these instructions).
- B. Wrong Sloan SOLIS® model installed; i.e., 1 gpf. Urinal installed on 3.5 gal. Closet fixture. Replace with proper Sloan SOLIS® model.
- C. Enlarged Bypass in Diaphragm. Replace Flex Tube Diaphragm.
- D. Control Stop not adjusted properly. Readjust Control Stop.
- E. Inadequate volume or pressure at supply. Increase water pressure or supply (flow) to valve. Consult factory for assistance.

8. Too Much Water to Fixture.

- A. Wrong Flush Volume Regulator installed in Flex Tube Diaphragm Kit. Install the correct Regulator (see Step 7 of these instructions).
- B. Control Stop not adjusted properly. Readjust Control Stop.
- C. Wrong Sloan SOLIS® model installed; i.e., 3 gpf. Model installed on 1.0 or 1.5 gal. Urinal fixture. Replace with proper Sloan SOLIS® model.
- D. Dirt in Diaphragm Bypass. Clean under running water or replace Flex Tube Diaphragm.

Note: The EBV-46-A Beam Deflector is not required or available for the Sloan SOLIS®.

CARE AND CLEANING INSTRUCTIONS

DO NOT use abrasive or chemical cleaners to clean Flushometers as they may dull the luster and attack the chrome or special decorative finishes. Use **ONLY** soap and water, then wipe dry with clean cloth or towel.

While cleaning the bathroom tile, the Flushometer should be protected from any splattering of cleaner. Acids and cleaning fluids can discolor or remove chrome plating.