

**APPLICATION**

For ON-OFF (two position) low voltage control of the amount of air brought into the cooling system with respect to the "total heat" (enthalpy) of the outside air. THC-3, THCR-4 and THCR-5 controllers replace Honeywell H205A series.

**SPECIFICATIONS**

**Control Dial Settings:** See Table 2. Intermediate settings are available. Mechanical stops at settings A and D for THCR-5.

**Sensing Elements:** Humidity, Nylon ribbon.

Temperature, Bimetal.

Controller will function as a dry bulb control if the nylon element should fail.

**Environment: Temperature Limits,**

Shipping, -40 to 150°F (-40 to 65°C).

Operating, 40 to 150°F (4 to 65°C).

Humidity, 5 to 95% R.H., non-condensing.

Locations, NEMA Type 1 indoor only.

**Electrical Switch:** Snap acting SPDT will run the outdoor air damper to the minimum position whenever the total heat in the outdoor air renders it unsuitable for cooling.

Rating, 100 mA to 2.5 amps at 24 Vac.

**Connections:**

THC-2, THCR-4, Three 6" (150 mm) color coded leads.

THC-3, THCR-5, Three 1/4" male quick connect (spade lug) terminals.

**Cover:** All metal; THC-2 and THCR-4 with 1/2" conduit opening.

**Mounting:** In any position where it is exposed to freely circulating outdoor air.

**Dimensions: THC-2, THCR-4,** 4-3/4" high x 6-1/2" wide x 3-1/2" deep (121 mm x 165 mm x 89 mm).

THC-3, THCR-5, 3-1/2" high x 5-1/8" wide x 1-1/8" deep (89 mm x 130 mm x 29 mm).

**ACCESSORIES** None

**Table-1 Competitive Replacement.**

	Replaces Honeywell
THCR-4	H205A-1012 H205A-1061
THCR-5	H205A-1004 H205A-1046 H205A-1095

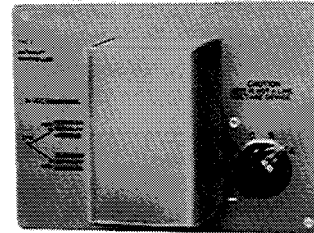

**THC-3**

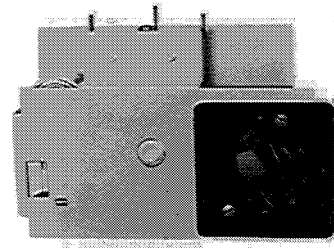

**THC-2  
THCR-5**

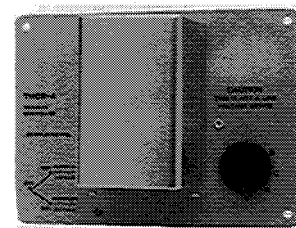

**THCR-4**

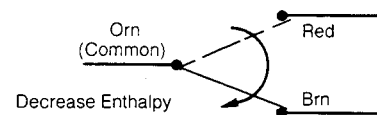

Figure-1 THC-2, THCR-4 Switch Action and Lead Identification.

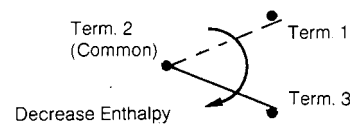

Figure-2 THC-3, THCR-5 Switch Action and Terminal Identification.

**Table-2 Control Settings.**

Part No.	Dial Setting	10% R.H.	20% R.H.	50% R.H.	80% R.H.
THC-2	A	88°F (31°C)	-	83°F (28°C)	74°F (23°C)
	B	83°F (28°C)	-	78°F (26°C)	70°F (21°C)
	C	78°F (26°C)	-	73°F (23°C)	64°F (18°C)
	D	73°F (23°C)	-	68°F (20°C)	59°F (15°C)
THC-3 THCR-4 THCR-5	A	-	78°F (26°C)	73°F (23°C)	68°F (20°C)
	B	-	73°F (23°C)	68°F (20°C)	63°F (17°C)
	C	-	68°F (20°C)	63°F (17°C)	59°F (15°C)
	D	-	62°F (17°C)	58°F (14°C)	53°F (12°C)

## THEORY OF OPERATION

The control dial setting should be selected from the psychrometric chart (see Figure 3 and 4 and Table 3). The areas to the right of each curve in the chart, determined by the control dial setting, represent enthalpy values in excess of those required by the application. Under these conditions the outdoor air damper should close to its minimum open position. The areas to the left of each curve represent enthalpy values where outdoor air should be utilized for cooling, i.e., outdoor damper open.

## PRE-INSTALLATION

### Inspection

Inspect the carton for damage. If damaged, notify the appropriate carrier immediately. If undamaged, open the carton and inspect the device for obvious damage due to shipping. Return damaged products. Check the part number on the unit to be sure the correct device is being installed.

### Required Installation Items

- Wiring diagrams
- Tools (not provided):  
 Volt-ohm meter  
 Appropriate screwdriver for mounting screws and terminal connections  
 Appropriate drill and drill bit for mounting screws
- Appropriate accessories
- Mounting screws (provided)
- Switching reference label provided for THCR-5

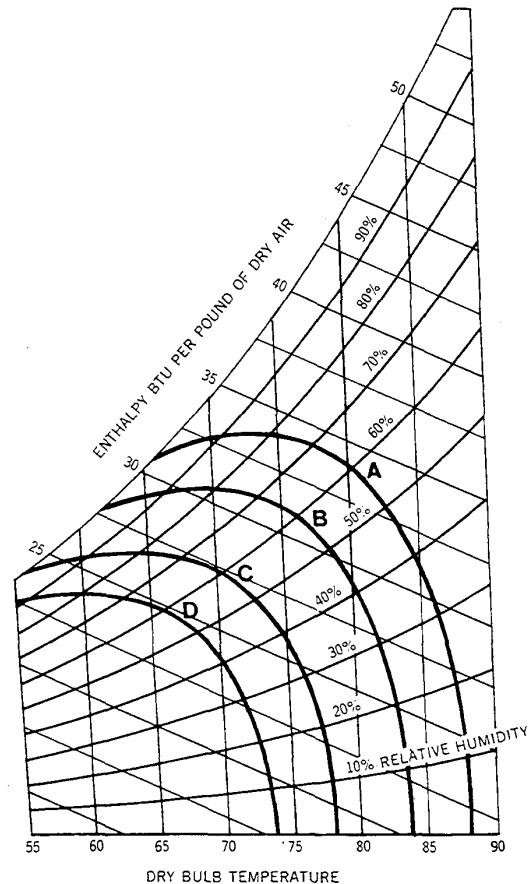

Figure-3 Psychrometric Chart with THC-2 Performance Curves Shown.

## INSTALLATION

### Caution:

- Installer must be a qualified, experienced technician.
- Disconnect power supply before installation to prevent electrical shock and equipment damage.
- Make all connections in accordance with the wiring diagram, and in accordance with national and local electrical codes.
- Do not exceed ratings of the device.
- Avoid locations where excessive moisture, corrosive fumes or vibration are present. NEMA Type 1 covers are intended for indoor use primarily to provide a degree of protection against contact with the enclosed device.

A THC enthalpy control can be installed in a new installation or replace an existing device. The control is normally mounted in a position where it is exposed to freely circulating outdoor air. Mounting on the inner surface of the outdoor air duct is usually satisfactory.

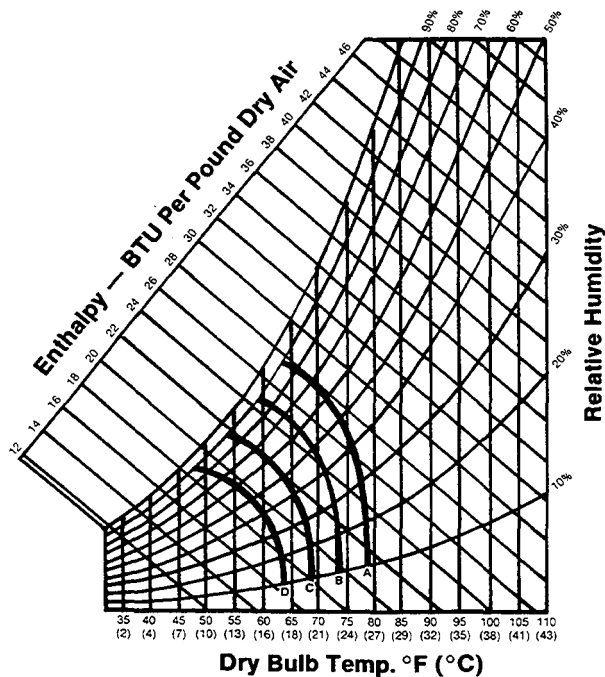

Figure-4 Psychrometric Chart with THC-3, THCR-4 and THCR-5 Performance Curves Shown.

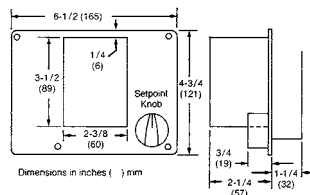

Figure-5 Dimensions of THC-2 and THCR-4.

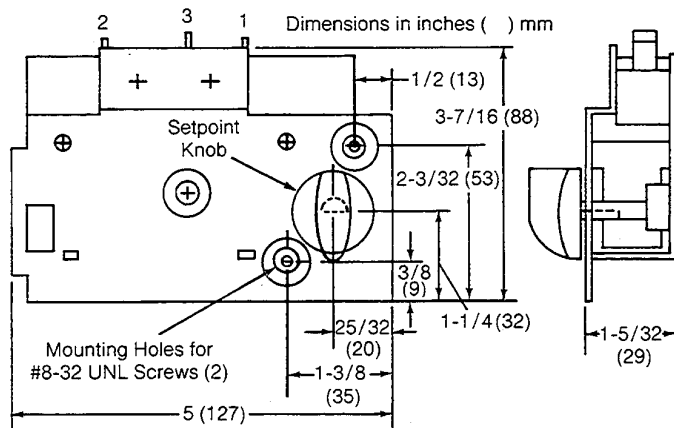

Figure-6 Dimensions of THC-3.

### THC-3, THCR-5 NEW INSTALLATION (or replacement of non-adjustable enthalpy devices) (See Figure 6 or 7)

#### Mounting

1. Horizontal upright position (see Figures 6 and 7).
  - a. Locate the scale plate on the outside.

- b. Mount the scale plate to the duct after removing the adhesive back and protective face coverings.
- c. Drill (2) 1/8" (3 mm) holes for the mounting screws and a 1/4" (6 mm) hole for the setpoint using the scale plate as a drilling template.

*Optional mounting positions for the THCR-5 only (See Figure 8):*

- a. Locate the scale plate on the outside of the duct.
  - b. Mount the scale plate to the duct after removing the adhesive back and protective face coverings.
  - c. Drill (2) 1/8" (3 mm) holes for the mounting screws and a 1/4" (6 mm) hole for the setpoint using the scale plate as a drilling template.
  - d. Select the scale label with an indicator line that will match the position of the control face plate indicator line.
  - e. Mount the scale label to the scale plate after peeling off the back protective covering.
2. Mount the control to the duct by inserting the setpoint shaft through the scale plate (from within the duct). Secure the control with the (2) self-tapping screws provided.
  3. Push setpoint knob onto the setpoint shaft.
  4. Apply a switching reference adhesive label next to the control dial for the THCR-5 only.

#### Wiring

1/4" spade connections are numbered 1, 2 and 3. See Figure 1 for SPDT switching action.

*Note: Make all connections in accordance with installation wiring diagram and in compliance with national and local electrical codes. Use copper conductors only.*

### THCR-5 EXISTING CONTROL REPLACEMENT

(H205A-1004, H205A-1046 and H205A-1095) (See Figures 2, 7 and 8)

#### Mounting

1. Label and remove the wires from the existing enthalpy control, noting field wiring colors and terminal connections 1, 2 and 3.
2. Remove the knob (pull off or loosen set screw) and unscrew the two mounting screws to remove the control.
3. Remove the adhesive backing and protective face covering from the scale plate.
4. Align the scale plate with existing duct holes and mount the scale plate to the duct.
5. Select the scale label with an indicator line that will match the position of the control face plate indication line.
6. Peel off the scale label protective backing and mount the label to the scale plate.

7. Mount the control to the duct by inserting the setpoint shaft through the scale plate (from within the duct). Secure the control with the (2) self-tapping screws provided.
8. Push setpoint knob onto the setpoint shaft.
9. Apply a switching reference adhesive label next to the control dial.

## Wiring

Reattach the 1/4" spade connections to the terminals marked 1, 2, and 3. See Figure 2 for SPDT switching action.

---

*Note:* Make all connections in accordance with the job wiring diagram and in compliance with national and local electrical codes. *Use copper conductors only.*

---

## THC-2, THCR-4 NEW INSTALLATION (or replacement of non-adjustable enthalpy devices)

### Mounting

1. Locate the mounting template on the duct. Press template onto duct after removing its adhesive backing.
2. Drill (4) mounting holes as indicated on the template, using 1/8" (3mm) dia. drill.
3. Cut out center portion of duct as outlined on template.
4. Mount controller to duct using (4) 1/2" #8 screws provided.

## Wiring

1/2" conduit opening and (3) 6" (150 mm) color coded leads. See Figure 1 for switch action.

---

*Note:* Make all electrical connections in accordance with job wiring diagram and in compliance with national and local electrical codes. *Use copper conductors only.*

---

## THC-2, THCR-4 EXISTING CONTROL REPLACEMENT (H205A-1012 and H205A-1061)

### Mounting

1. Label and remove the wires from the existing enthalpy control, noting wire colors.
2. Unscrew the (4) mounting screws and remove the control.
3. Mount controller to duct using (4) 1/2" #8 screws provided.

### Wiring

1/2" conduit opening and (3) 6" (150 mm) color coded leads. See Figure 1 for switch action.

---

*Note:* Make all electrical connections in accordance with job wiring diagram and in compliance with national and local electrical codes. *Use copper conductors only.*

---

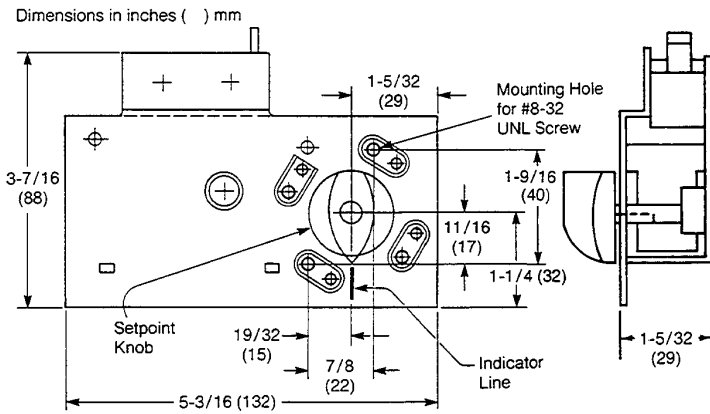
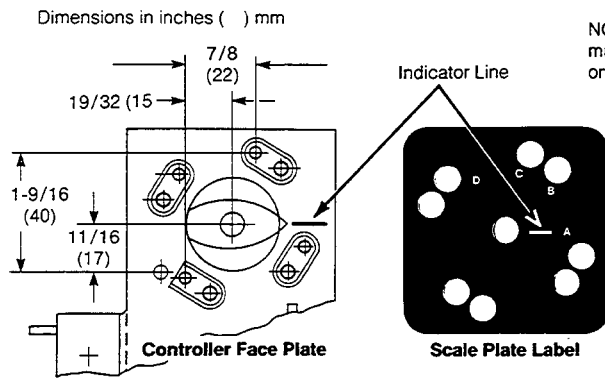
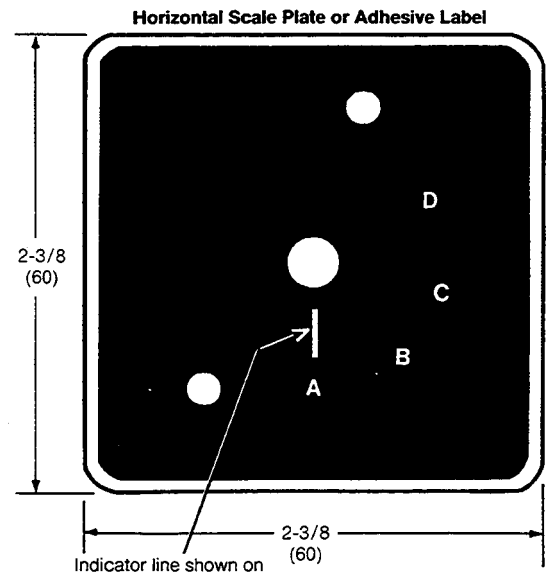

Figure-7 Horizontal Upright Mounting Dimensions on THC-3 and THCR-5.



NOTE: Indicator line on label must align with indicator line on controller face plate.

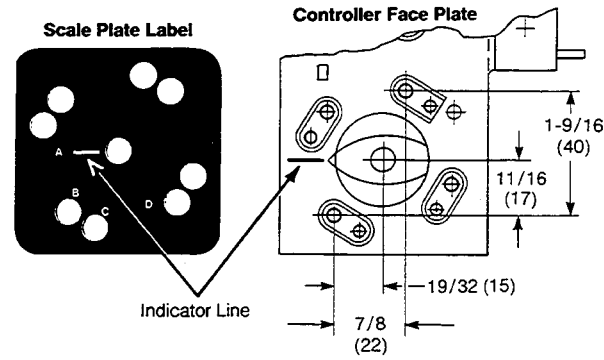
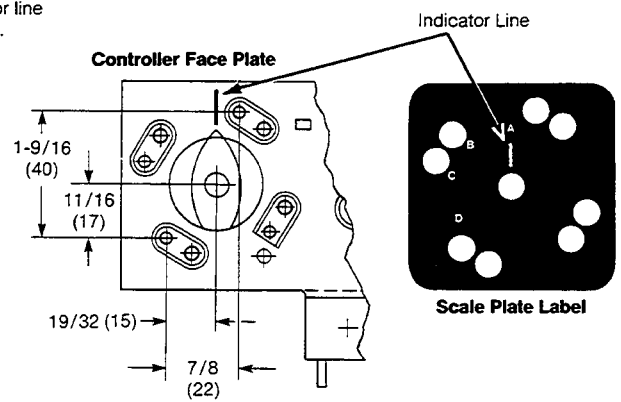

Figure-8 Optional Mounting Dimensions for THCR-5.

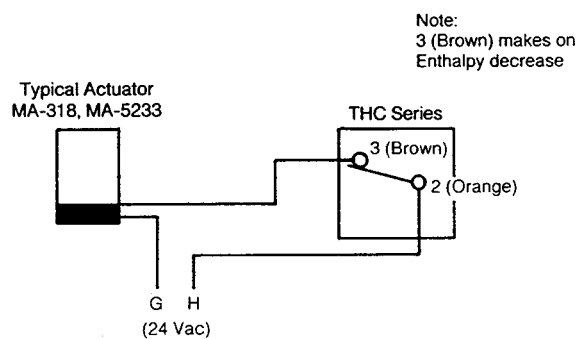

Figure-9 Economizer System with Two-Position Control.



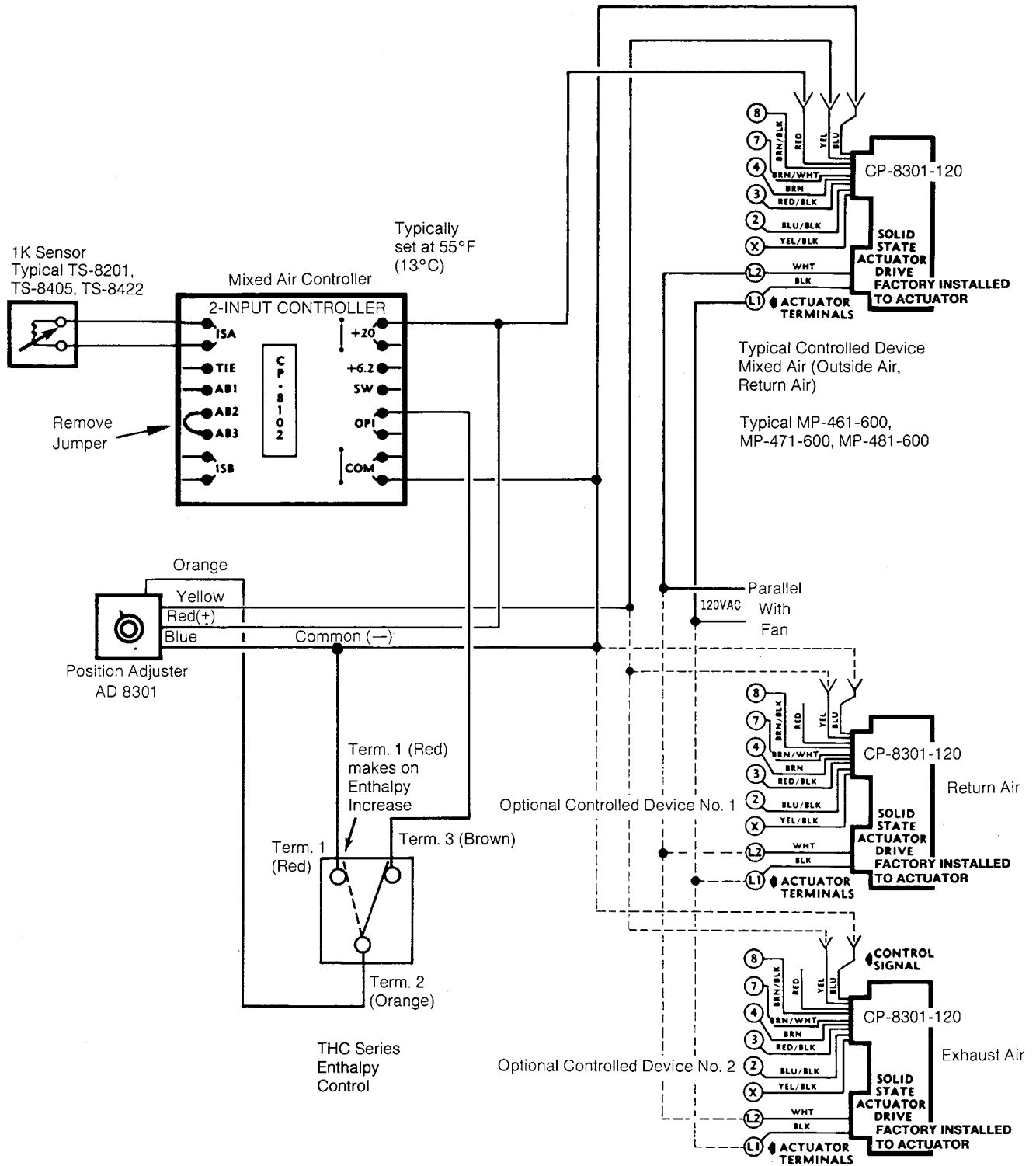
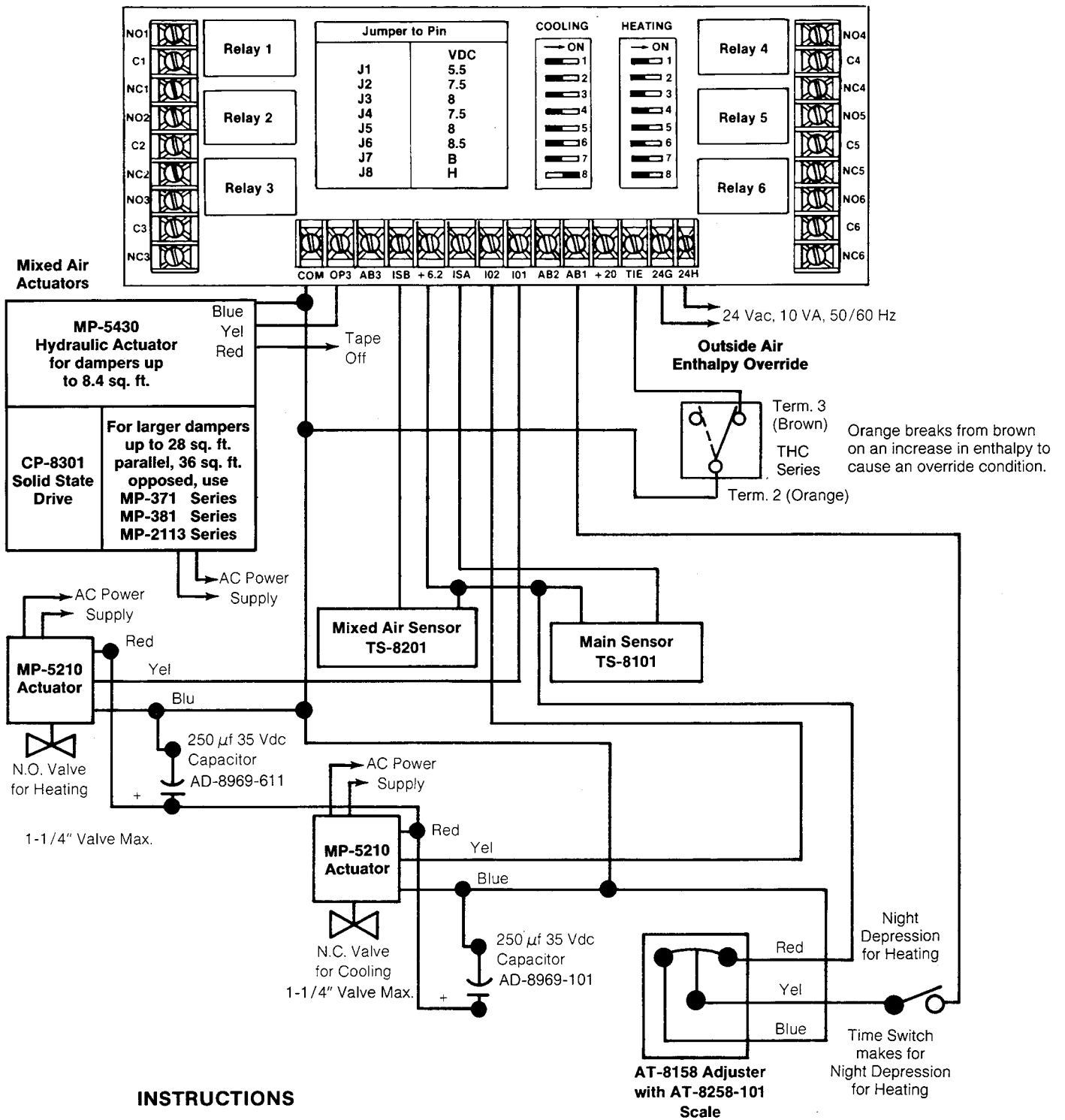

Figure-12 Economizer Cycle Using TAC System 8000 and Enthalpy Controls.

CP-8161-333



**INSTRUCTIONS**

Set jumpers and dip switches as shown above. Heating and cooling throttling ranges TRA and TRB are factory set at 3°F and may be adjusted to 2° to 10°F.

Minimum mixed air damper position is factory set at 25% and can be adjusted from 0 to 100%.

MASP adjustment (mixed air start point) is factory set to be 100% open at just below the cooling setpoint and is adjustable to 1 cooling TR below the cooling setpoint.

Set the AT-8158 Dial for the required night deviation temperature.

**Note: CP-8161-333 Settings**  
 Jumper Pin F to Pin C (factory set)  
 Place Jumper J8 to Pin H

Figure-13 CP-8161-333 Valve Heating and Cooling/Mixed Air/Enthalpy Override/Night Setback.

CP-8161-333

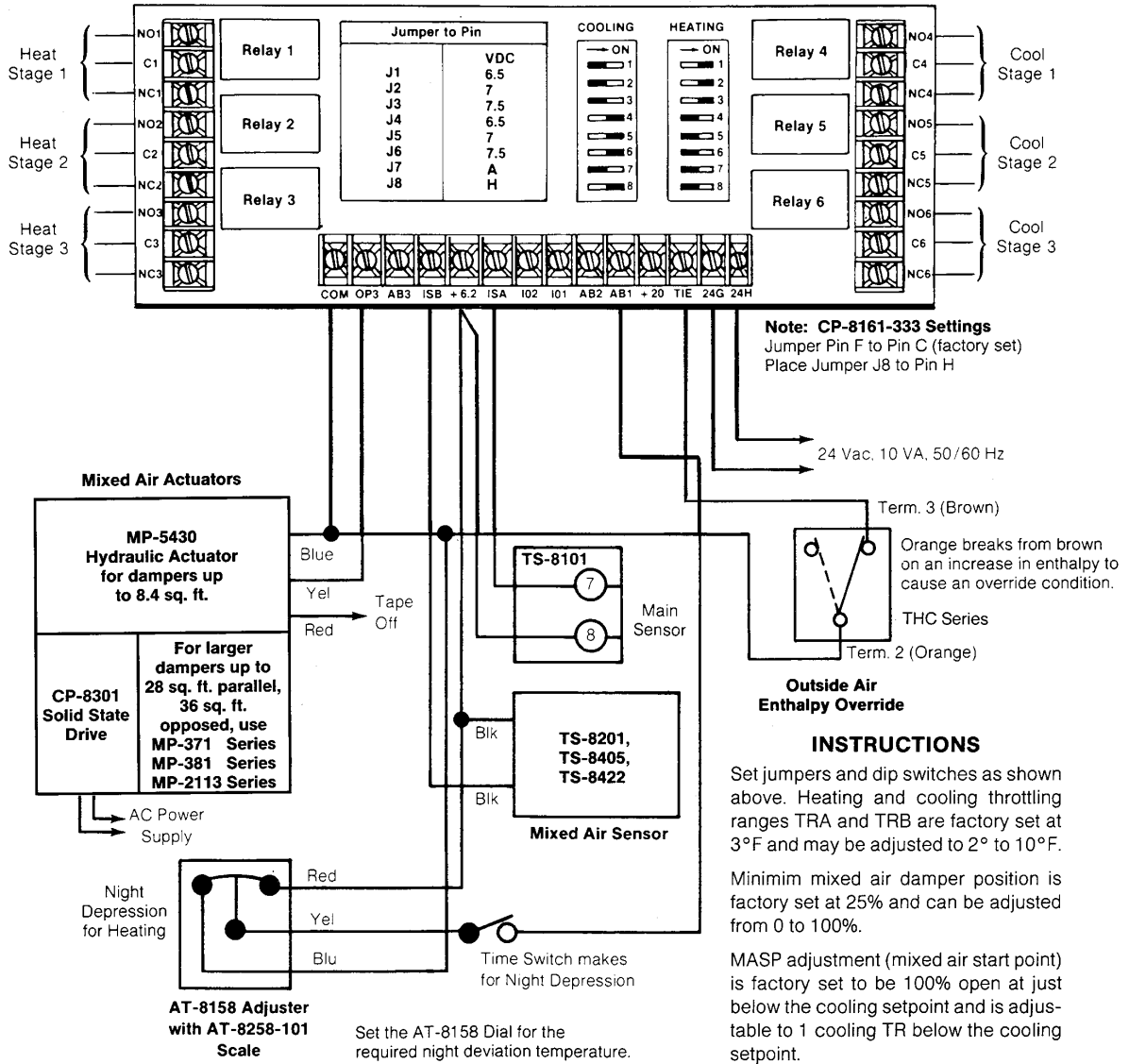

Figure-14 CP-8161-333 Three-Heat/Three Cool/Mixed Air Enthalpy Override and Night Setback.

## CHECKOUT

Check that wiring is made in accordance with the job wiring diagram. Set the knob to the "A" scale. The outdoor air damper should go to the open position unless outdoor air conditions are to the right of curve "a", (Figures 3 and 4). Set the knob to the "D" scale and outdoor air damper should close unless outdoor air conditions are to the left of curve "D", (Figures 3 and 4).

## CALIBRATION

All controllers are calibrated at the factory and no field calibration should be required or attempted.

## INSTRUCTIONS

Set jumpers and dip switches as shown above. Heating and cooling throttling ranges. TRA and TRB are factory set at 3°F and may be adjusted to 2° to 10°F.

Minimum mixed air damper position is factory set at 25% and can be adjusted from 0 to 100%.

MASP adjustment (mixed air start point) is factory set to be 100% open at just below the cooling setpoint and is adjustable to 1 cooling TR below the cooling setpoint.

## MAINTENANCE

Regular maintenance of the total system is recommended to assure sustained optimum performance.

## FIELD SERVICE

Do not field repair the control. If the system is not operating properly and the reason is traced to the enthalpy control, replace the control.



---

Copyright 2008, TAC  
All brand names, trademarks and registered  
trademarks are the property of their respective  
owners. Information contained within this  
document is subject to change without notice.

F-20009-6

**TAC**  
1354 Clifford Avenue  
P.O. Box 2940  
Loves Park, IL 61132-2940  
[www.tac.com](http://www.tac.com)

**t.a.c.** <sup>®</sup>  
**by Schneider Electric**