



**TAC**  
 1354 Clifford Avenue  
 P. O. Box 2940  
 Loves Park, IL 61132-2940  
 www.tac.com

## Control Module for MM-400/500 Series & MMR-400/500 Series Modular Motors General Instructions

### APPLICATION

The MMC-468 plug-in control module is used in conjunction with MM-400, MM-500, MMR-400 and MMR-500 series of modular motors.

The module will accept Honeywell Series 40, 60, 80, and Johnson Type "A" 2-position control signals.

#### Each MMC-468 package contains:

- One (1) MMC-468 Control Module
- One (1) Module Label
- Five (5) 6"-18 gage color coded wires with 1/4" Spade Connector attached to one end.
- Three (3) Insulated 1/4" Spade Connectors
- One (1) Wiring template

#### Other TAC Components Required:

None

#### Other TAC Components That May Be Required:

None

### SPECIFICATIONS

#### Control Signal Inputs:

##### 2-position SPST, (MM or MMR-500 spring return series)

The SPST control switch is switching the power to the motor [1 amp @ 24 Vac (Triac input 2A @ 200 Vac minimum), 0.2 amp @ 120 Vac, 0.12 amp @ 208 Vac, 0.1 amp @ 240 Vac].

Control Module allows MM or MMR-500 Motor to directly interface with Honeywell Series 40 and 80 and Johnson type "A" control circuits.

##### 2-position SPDT (snap acting or floating), (MM or MMR-400 non-spring return series and MM or MMR-500 spring return series)

The SPDT control switch is operating a 24Vac relay on the MMC-468 module and must be rated at a minimum of 1 amp at 24 Vac. Triac input 2A @ 200 Vac minimum.

Control Module allows MM or MMR-400 Motor to directly interface with Honeywell Series 60 and Johnson type "A" control circuits.

#### Ambient Temperature Limits,

**Shipping and Storage** -40 to 160°F (-40 to 71°C)

**Operating** -40 to 140°F (-40 to 60°C)

**Humidity** 5 to 95% RH, non-condensing

**Locations**, NEMA Type 1 indoor only when installed in MM or MMR series of motors without AM-232 gasket installed, NEMA Type 3R with AM-232 installed (AM-232 provided with MMR series of motors) and motor mounted vertically - top up.

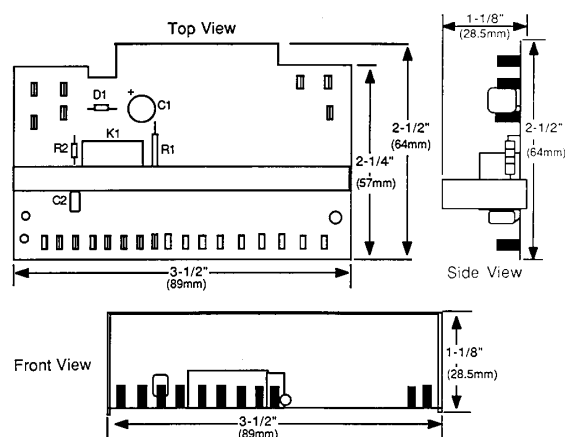
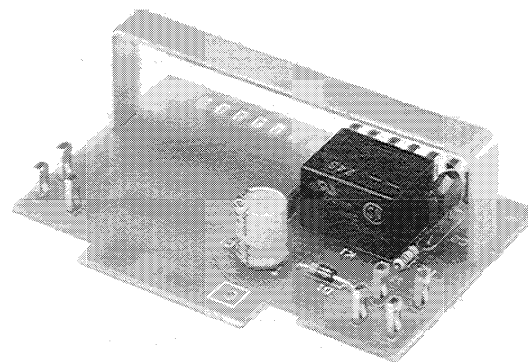

Figure-1 MMC-468 Plug-In Control Module Dimensions.

**Adjustments:** The mechanical stroke of motor is factory set for 160°; adjustable to 75°, 90°, or 110° by use of the internal mechanical stop (See General Instructions, F-23348). Other adjustments are made in the linkages.

Make sure the mechanical stroke is properly set before the control module is installed.

**Auxiliary Potentiometer:** 1K ohm  $\pm$  10%, 2 watts. For 160° rotation of the motor the potentiometer changes approximately 657 ohm  $\pm$  11%. See Table-1.

**Connections:** The motor has 1/4" spade lugs. The MMC-468 includes 6" (152.4 mm) color coded leads crimped to 1/4" female disconnects. Field connections should be made to color coded leads.

**Parallel Operation:** Up to 6 MMC-468 with MM or MMR-500 series of motors (only) can be controlled from one snap acting switch if the switch has sufficient rating. MM or MMR-400 series CAN NOT be paralleled.

To parallel; tie all Red wires (Terminal 3) together, all White/Black wires (Terminal 4) together, and all Blue Wires (Terminal 5) together.

**Interchangeability:** The MMC-468 and the MM or

MMR-400 series of motors are interchangeable with Honeywell's Series 60 (SPDT floating or snap acting) motors. The MMC-468 and the MM or MMR-500 series of spring return motors are interchangeable with Honeywell's Series 40 and 80 (SPST) motors. The motors can use the standard Honeywell accessories such as damper and valve linkages.

**Mounting:** Plug-in mounting in the MM or MMR series of motors. MMC-468 is not position sensitive.  
**Dimensions:** 1-1/8" high x 3-1/2" wide x 2-1/2" deep (28.5 mm x 89 mm x 64 mm) See Figure-1.

**Table-1 Potentiometer Resistance Change For Full Stroke (160° Rotation) of The Motor.**

Load End or N.C. End of Motor	Optional End or N.O. End of Motor	Resistance Terminal 7 (Wiper) to 6	Resistance Terminal 7 (Wiper) to 8
CCW End of Motor Stroke	CW End of Motor Stroke	343 ohms ± 11%	657 ohms ± 11%
CW End of Motor Stroke	CCW End of Motor Stroke	957 ohms + 15%, -10%	0 to 75 ohms

## PRE-INSTALLATION

### Inspection

Visually inspect the package for damage. If damaged, notify the appropriate carrier immediately. If undamaged, open the package and visually inspect the device for obvious defects. Return damaged or defective products.

### Required Installation Items

- Wiring diagram
- Tools (not provided):  
 Digital volt-ohm meter (DVM)  
 Screwdriver
- Multi-purpose crimp tool (Required only if the feedback potentiometer is used.)

## INSTALLATION

### Caution:

Installer must be a qualified, experienced technician.

Disconnect power supply before installation to prevent electrical shock and equipment damage.

Make all connections in accordance with electrical wiring diagrams, and in compliance with national and local codes. Use copper conductors only that are suitable for 85°C. Use class 1 wiring only.

Do not exceed the ratings of the device.

Avoid locations where excessive moisture corrosive fumes or vibration are present.

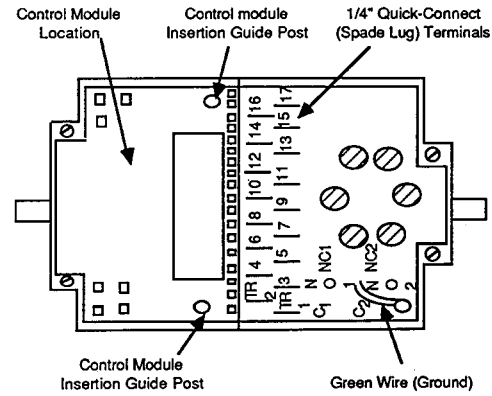

Figure-2 Terminal Board Connections and Control Module Location.

## Mounting and Wiring

1. Remove the motor cover by removing the four cover screws.

*Note:* If maximum output shaft rotation needs to be changed (factory set at 160°), see **Adjustments** before installing control module.

2. Pick up the control module by the metal installation handle and install the MMC-468 control module into the motor wiring compartment by aligning the module and carefully pushing all the way onto the pins. Press in the area around both sides of the vertical part of handle.
3. Make the wiring connections in accordance with job wiring diagram (See Figures 4 through 6 and Tables 2 and 3).
4. The field connections are made to 6" (152.4 mm) long color coded leads. The color coded leads are supplied with MMC-468 and have 1/4" female disconnects crimped to them.
5. The template supplied can be used for easy terminal installation. Place the template over the terminal block (See Figure-3).
6. Install the leads to 1/4" spade lugs in the motor referring to Figures 4 through 6.
7. Install the wiring label included with MMC-468 control module on the inside of the motor cover so that the configuration of the motor can be determined at a later date.

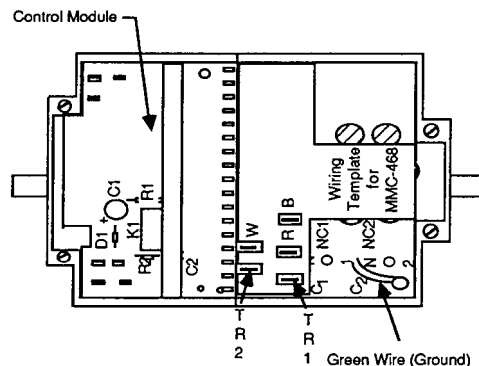

Figure-3 Terminal Board Connections with Wiring Template.

8. Replace the motor cover and covers screws if the checkout is not being done at this time.

**Table-2 Wire Selection for Control Wiring to SPDT Switch.**

Wire Size (AWG)	Maximum Run FT. (m)
18	95 (28.9)
14	250 (76.2)
12	390 (118.8)

**Table-3 Wire Selection for Power Wiring to Motor or AM-231 Cover Transformer.**

Voltage	Wire Size (AWG) (Suitable for 85°C)	Maximum Run <sup>a</sup> Feet (m)
24 <sup>b</sup>	18	95 (28.9)
	14	250 (76.2)
	12	390 (118.8)
120	14	2,700 (823)
208/240	14	4,700 (1,432)

<sup>a</sup> The maximum run is based on one motor being on the run. If more than one motor is on the run, divide the maximum run length shown in the table by the number of motors to determine actual maximum run length.

<sup>b</sup> The maximum wire run includes the wire run to the SPDT control switch.

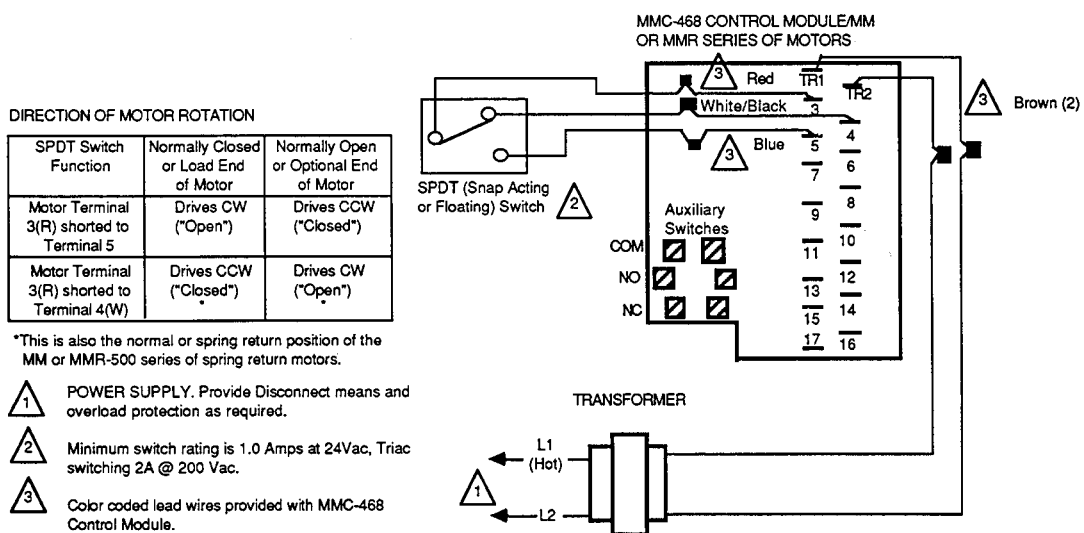

Figure-4 MMC-468 Control Module and MM or MMR Series of Motors Controlled by SPDT (Snap Acting or Floating) Switch.

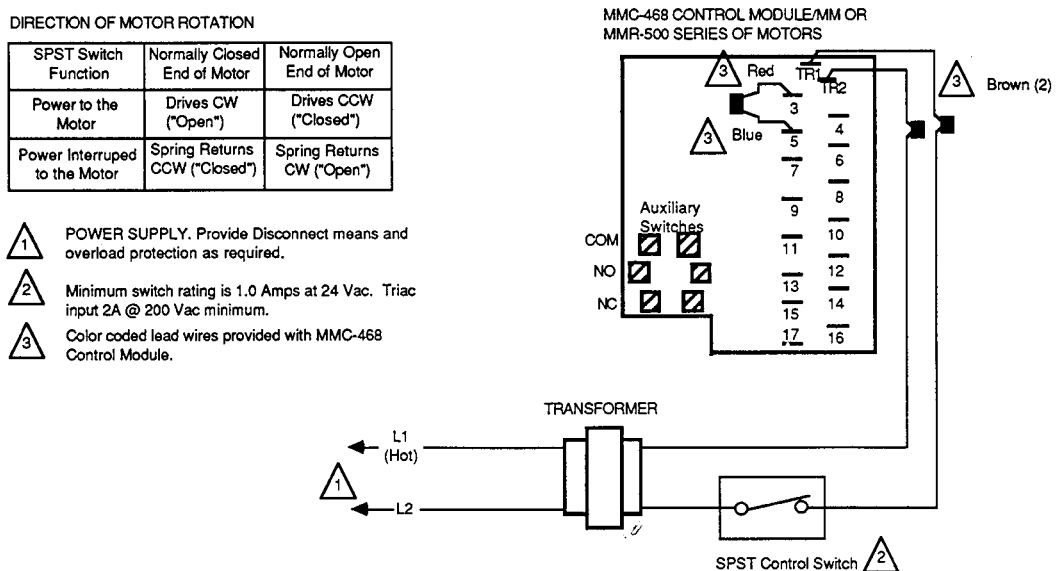

Figure-5 MMC-468 Control Module and MM or MMR-500 Series of Motors Controlled by SPST Switch (Low Voltage).

DIRECTION OF MOTOR ROTATION

SPST Switch Function	Normally Closed End of Motor	Normally Open End of Motor
Power to the Motor	Drives CW ("Open")	Drives CCW ("Closed")
Power Interrupted to the Motor	Spring Returns CCW ("Closed")	Spring Returns CW ("Open")

- 1 POWER SUPPLY. Provide Disconnect means and overload protection as required.
- 2 Minimum switch rating is 0.2 Amps at 120 Vac, 0.12 Amps at 208 Vac and 0.1 Amps at 240 Vac.
- 3 Color coded lead wires provided with MMC-468 Control Module.

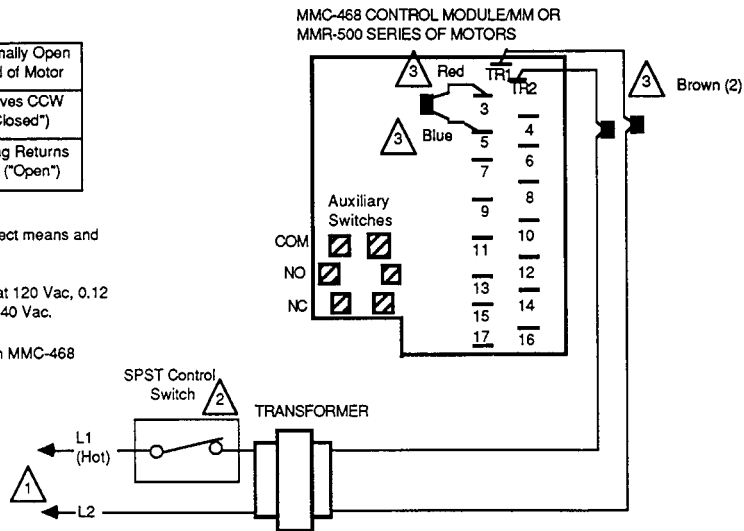

Figure-6 MMC-468 Control Module and MM or MMR-500 Series of Motors Controlled by SPST Switch (Line Voltage).

**Direction of Motor Rotation Versus Input Signal to MMC-468 Control Module**

The MM and MMR series of motors can have the load attached to either end of the motor. The ends of the MM and MMR-400 series of non-spring return motors are identified as the "Load" (end typically used for load) and "Optional". The ends of the MM and MMR-500 series of spring return motors are identified as the "Normally Closed" (CCW spring return, end typically used for load) and the "Normally Open" (CW spring return). The tables shown below describe the direction of rotation of the two ends of the motor versus the different input signals that the MMC-468 control module will accept.

**Table-4 Direction of Rotation of MM or MMR-500 Series of Spring Return Motors Versus Series 40 or 80 (SPST) Controller. See Figures-5 and 6.**

SPST Switch <sup>a</sup> Function	Normally Closed End of Motor	Normally Open End of Motor
Power to the Motor	Drives CW ("Open")	Drives CCW ("Closed")
Power Interrupted to the motor	Spring Returns CCW ("Closed")	Spring Returns CW ("Open")

<sup>a</sup> Install a jumper between terminals 3(R) and 5(B) on the motor.

**Table-5 Direction of Rotation of MM or MMR Series of Motors Versus Series 60 (SPDT Snap Acting or Floating). See Figure-4.**

SPDT Switch Function	Normally Closed or Load End of Motor	Normally Open or Optional End of Motor
Motor Terminal 3(R) Shorted to Terminal 5(B)	Drives CW ("Open")	Drives CCW ("Closed")
Motor Terminal 3(R) Shorted to Terminal 4(W)	Drives CCW ("Closed") <sup>a</sup>	Drives CW ("Open") <sup>a</sup>

<sup>a</sup> This is also the normal or spring return position of the MM or MMR-500 series of spring return motors.

**CHECKOUT**

After the entire system has been installed and the motor has been powered up, the following checks can be made for proper system operation. Also refer to the General Instruction sheet(s) for the motor and any accessories during the checkout procedure.

*Note:* The MMC-468 has no adjustments. All adjustments are made in the motor, the linkages or accessories.

**Positioning the Motor with the Controller**

If the sensed media is within the controllers setpoint range, the motor can be positioned by adjusting the controller setpoint up and down. Check for proper operation of the system as the motor is operated.

# THEORY OF OPERATION

## General Description of MM or MMR-400 Series of Motors

The MM and MMR-400 series of motors have a permanent split capacitor motor (See Figure-7). The capacitor causes the magnetic fields of the two coils to be out-of-phase which results in a rotating field that causes the rotor to turn. The power can be connected to either field coil. There is a phase shift and change in direction of rotation when the power to the coils is reversed. The motors are of the torque limiting type. That is when the motor is being driven in one direction and torque exceeds the trip point of the switch, the switch opens and stops the motor. Therefore the motor stops when the motor hits its internal mechanical stops, the valve seat or damper stops.

## General Description of MM or MMR-500 Series of Motors

The MM and MMR-500 series of spring return motors have a permanent split capacitor motor that drives the motor in one direction and spring that powers it in the other direction (See Figure 8). When power is applied to the motor coil, the brake winding is not provided releasing the brake allowing the motor to run. The torque limit switch wired to the motor coils operates the same as MM or MMR-400 series. To drive the motor in the spring return direction power is applied to terminal 4(W) pulling in the K1 relay which releases the brake allowing motor to spring return.

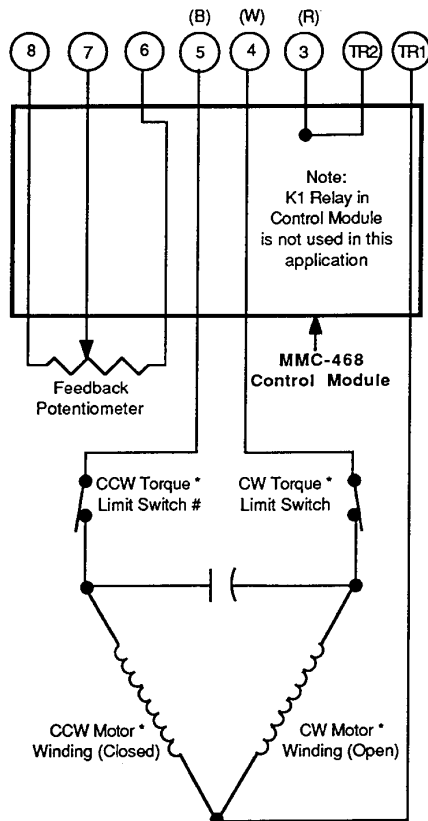

\* Direction of travel as viewed from "Load" end of the motor.  
 # The CW mechanical limit of the motor is adjustable to provide 75, 90, 110 and 160° travel.

Figure-7 Internal Schematic of MM or MMR-400 Series of Non-Spring Return Motors with MMC-468 Control Module.

## SPDT Control Switch with MM or MMR-400 Series and MM or MMR-500 Series of Motors

The common of the SPDT control switch is connected to terminal 3(R) of the motor and the other two contacts of the switch are connected to terminals 4(W) and 5(B). When the switch shorts terminals 3(R) and 5(B), the motor will drive in the open (CW) direction with respect to the "Load" or "Normally Closed - CCW Spring Return" end of motor. When the switch shorts terminals 3(R) and 4(W), the motor will drive to the closed (CCW) direction with respect to the "Load" or "Normally Closed - CCW Spring Return" end of motor.

## SPST Control Switch with MM or MMR-500 Series of Motors

The SPST switches the power to motor. The motor must have a jumper installed between terminals 3(R) and 5(B) of the motor. When power is applied the motor drives to the open (CW) position with respect to the "Normally Closed - CCW Spring Return" end of motor. When the motor is not powered the motor will spring return to the closed (CCW) position with respect to the "Normally Closed - CCW Spring Return" end of motor.

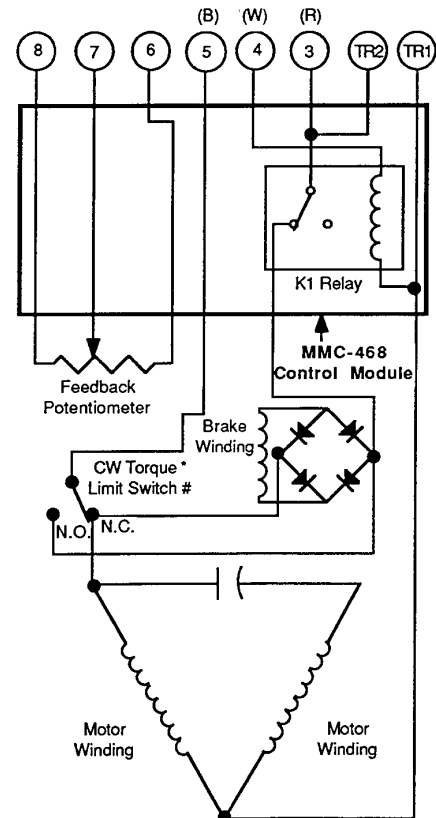

\* Direction of travel as viewed from the "Normally Closed-CCW" end of the motor.  
 # The CW mechanical limit of the motor is adjustable to provide 75, 90, 110 and 160° travel.

Figure-8 Internal Schematic of MM or MMR-500 Series of Spring Return Motors with MMC-468 Control Module.

## **MAINTENANCE**

Regular maintenance of the total system is recommended to assure sustained optimum performance.

## **FIELD REPAIR**

None. Either replace MMC-468 and or motor as required.



---

Copyright 2006, TAC  
All brand names, trademarks and registered  
trademarks are the property of their respective  
owners. Information contained within this  
document is subject to change without notice.

**TAC**  
1354 Clifford Avenue  
P.O. Box 2940  
Loves Park, IL 61132-2940

F-23349-3



[www.tac.com](http://www.tac.com)

