



TAC
1354 Clifford Avenue
P. O. Box 2940
Loves Park, IL 61132-2940
www.tac.com

MF-5X13 Series MF-5X33 Series

Floating Hydraulic Actuator General Instructions

APPLICATION

The MF-5X13 and MF-5X33 Series are small hydraulic spring return actuators which provide floating control of hydronic heating and cooling valves or dampers.

Features

- Floating actuators controlled by SPDT floating controllers or DDC controllers with 2 SPST (drive open, hold, drive close) outputs
- Spring return
- All models 24 Vac; optional AM-610 transformer available for 120, 208, or 240 Vac
- Adjustable SPDT auxiliary switch on -500 models
- Models available with potentiometer position feedback
- Available in damper models or base models that require damper or valve linkage
- Die cast lower housing and painted steel upper housing
- Hydraulic actuator with oil immersed motor and pump

Applicable Literature

- TAC Cross-Reference Guide, F-23638
- TAC Reference Manual, F-21683
- TAC Application Manual, F-21335
- Engineering Bulletin EN-110, Damper Actuator Sizing, F-15260
- AM-610 Transformer General Instructions, F-24859
- Valve Linkage General Instructions, F-19069
- Valve Selection Guide, F-24949
- Material Safety Data Sheet MSDS-12

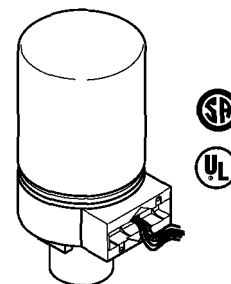

**MF-5X13 Series
Valve Actuator**

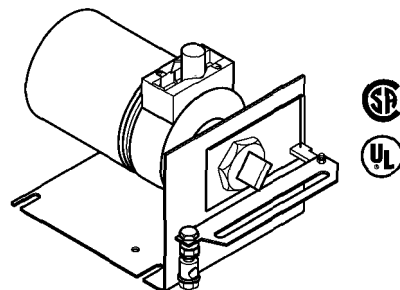

**MF-5X33 Series
Damper Actuator**

SPECIFICATIONS

Actuator Inputs:

Control Signal:

SPDT Floating Control Output or 2 SPST Control Contacts, Minimum rating of 1 A @ 24 Vac, inductive load. Refer to Figure-1.

Triacs, DDC controller output must be able to switch 1 A inductive load (200 V minimum).

Power Input: Refer to Table-1 and Table-2. All 24 Vac circuits are Class II.

Connections: Color-coded 4 ft. (1.2 m) leads.

Actuator Outputs:

Electrical:

Auxiliary Switch (-500 models, SPDT), externally adjustable over actuator stroke of 9/16". Factory-set to make N.C. contact at 1/8" from full retracted end of stroke.

Rating, 120/240 Vac, 50/60Hz, 10 amp, 1/4 hp, Pilot duty rating: 24 Va @ 24 Vac; 120 VA @ 120/208/240 Vac.

Position Feedback Signals, Refer to Table-1 and Table-2.

Mechanical:

Stroke,

Damper Approximately 2" (51 mm) from fully retracted to fully extended (includes AM-601 linkage). Refer to Table-1 for models.

Valve Approximately 9/16" (14.3 mm) from fully retracted to fully extended. Refer to Table-2 for models.

Nominal Damper Area, Nominal damper rating is 8.4 ft.² for parallel and 10.8 ft.² for opposed blade standard dampers (not low leakage) with 2000 fpm (10.2 m/s) velocity @ 1 in. H₂O (0.25 kPa) static pressure. For damper ratings under other operating conditions, refer to Engineering Bulletin EN-100 (Damper Actuator Sizing), F-15260.

Drift, Actuator movement in hold mode.

Damper 0.8"/hr. max. (2 mm/hr.).

Valve 0.02"/hr. max. (0.5 mm/hr.).

Environment:

Ambient Temperature Limits:

Shipping & Storage, -40 to 160°F (-40 to 71°C).

Damper, -20 to 140°F (-29 to 60°C).

Valve, Refer to Table-3.

Humidity: 5 to 95% RH, non-condensing.

Location: NEMA Type 1.

Table-1 Model Chart for Damper Actuators.

Part Number	Actuator Power Input				Feedback 15K ohm Potentiometer	Aux Switch	Timing in Seconds @ 75°F No Load Stroke		Approximate Output Torque Rating lb.-in. (N-m)
	AC Voltage +10/-15%	Hz	VA	Watts			To Extend	To Retract	
MF-5433	24	60	22	11	No	No	65	57	20 (2.3)
MF-5533		50	28	13	Yes	No			

Table-2 Model Chart for Valve Actuators. Also for Damper Actuators with Field Assembled Damper Linkages.

Part Number	Actuator Power Input				Feedback 15K ohm Potentiometer	Aux Switch	Timing in Seconds @ 75°F No Load Stroke		Required Linkage	
	AC Voltage +10/-15%	Hz	VA	Watts			To Extend	To Retract	Damper	Valve
MF-5413	24	60 50	22 28	11 13	No	No	65	57	AM-601	AV-600*
MF-5413-500					No	Yes				
MF-5513					Yes	No				
MF-5513-500					Yes	Yes				

*May require AV-601. Refer To Table-3.

Table-3 Restrictions on Maximum Ambient Temperature for Valve Actuators.

Maximum Temperature of Media in the Valve body (Check Rating of the Valve) °F (°C)	Max. Ambient Temperature of MF-5XXX Series	
	AV-600 Only for Chilled Water Applications °F (°C)	AV-600 and AV-601 °F (°C)
366 (180)	Do Not Use	88 (31)
340 (171)		93 (34)
281 (138)		103 (39)
181 (83)		120 (48)
140 (60)		140 (60)
80 (26)	140 (60)	140 (60)

ACCESSORIES

Common

- AM-610 Nipple-mounted transformer 120/208/240 Vac 50/60 Hz 40 VA (for mounting on conduit box)
- 11-1812 1/2" conduit bushing

Damper Only

- AD-931-105 External minimum positioner
- AM-111 Crank arm for 5/16" diameter damper shaft
- AM-112 Crank arm for 3/8" diameter damper shaft
- AM-113 Crank arm for 1/2" diameter damper shaft
- AM-115 Crank arm for 7/16" diameter damper shaft
- AM-122 Linkage connector straight type
- AM-123 Damper clip
- AM-125 5/16" diameter x 20" damper rod
- AM-125-048 5/16" diameter x 48" damper rod
- AM-132 Ball joint connector
- AM-161-3 Damper linkage kit
- AM-601 Device includes mounting bracket, damper linkage with spring and AM-122 straight connector. Required to modify MF-5X13 series valve actuators into 2" (51 mm) stroke damper actuators.

Valve Only

- AV-600 Valve linkage
- AV-601 Valve linkage extension for hot water and steam applications; requires AV-600

TOOLS

TOOL-10

Multipurpose magnetic screwdriver for Span, Zero, and minimum position adjustment

TOOL-12

Wrench for adjustment of auxiliary switch

TOOL-19

Spring compression tool for AV-600

TOOL-37

1-5/8" open-end wrench

TYPICAL APPLICATIONS (wiring diagrams)

Basic Actuator

Figure-1 illustrates a typical wiring diagram using an MF-5XXX-XXX and a transformer kit (AM-610). Two single-pole, single-throw contacts can also be used to control the actuator position.

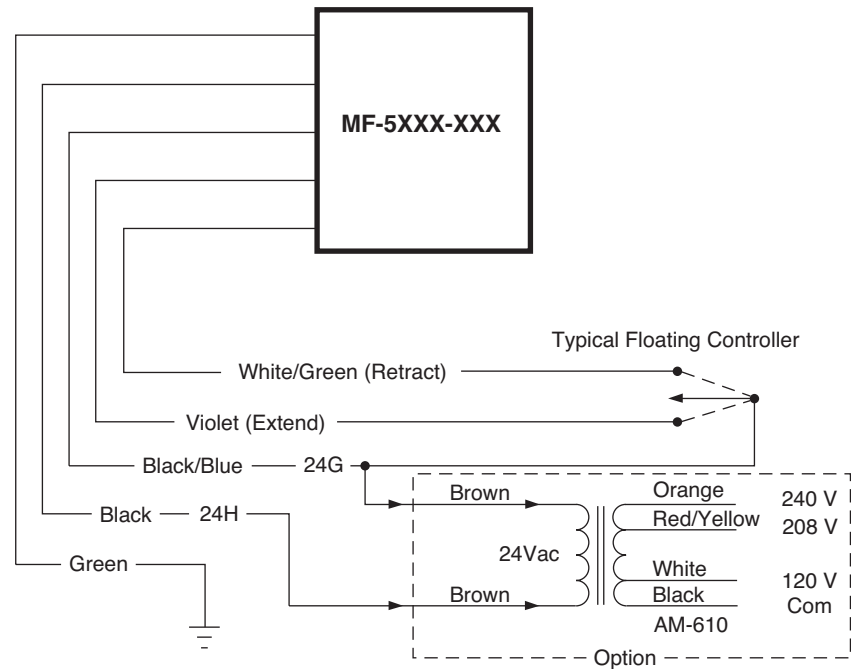

Figure-1 Basic Wiring Diagram.

15K Feedback (MF-55X3 Series)

The MF-55X3 series models contain a 15K ohm (15%) position feedback potentiometer (pot) to indicate the actuators stroke position. Refer to Figure-2.

Caution: Use the potentiometer in its intended three-wire mode instead of in a rheostat (two-wire) mode. Consult the factory on the rheostat mode.

When used in a DDC system, the maximum voltage between the white/brown and white/orange leads should be 24 volts AC or DC. With a voltage applied across the 15K ohm potentiometer element the input impedance for the white/blue lead must be 10,000 ohms or greater. The maximum current through the white/blue lead should not exceed 0.0024 amps (2.4 mA).

In the retract position the resistance between the white/blue lead and the white/orange lead is 100 to 700 ohms as measured with a voltmeter.



Figure-2 15K Feedback Potentiometer for MF-55X3 Series Models.

Auxiliary Switch (-500 Models)

The auxiliary (aux) switch can be adjusted by turning the aux. switch screw to change the switch action through the stroke of the unit (refer to Figure-3). The factory setting has the N.C. contact made at the retracted position.

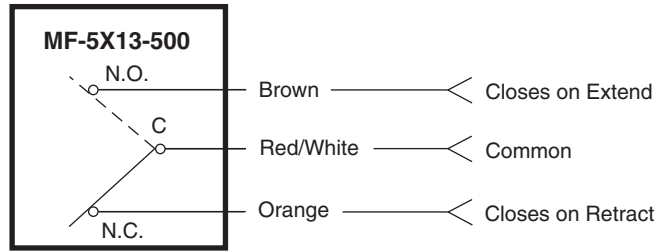

Figure-3 Auxiliary Switch for MF-5X13-500 Models.

INSTALLATION

Inspection

Inspect the package for damage. If damaged, notify the appropriate carrier immediately. If undamaged, open the package and inspect the device for obvious damage. Return damaged products.

Requirements

- Job wiring diagrams
- Tools (not provided):
 - Digital Volt-ohm Meter (DVM)
 - Appropriate drill and drill bit for mounting screws
 - Appropriate screw drivers and wrenches
 - TOOL-12, Wrench for adjustment of auxiliary switch
 - TOOL-19, Spring compression tool for AV-600
 - TOOL-37, 1-5/8" open-ended wrench
- Training: Installer must be a qualified, experienced technician.



Warning:

- Disconnect the power supply (line power) before installation to prevent equipment damage.
 - Make all connections in accordance with the wiring diagram and in accordance with national and local electrical codes. *Use copper conductors only.*
-

Caution:

- Do not exceed the ratings of the device(s).
 - Do not apply power to the unit unless the damper linkage and/or the valve assembly have been installed.
 - Avoid locations where excessive moisture, corrosive fumes, or vibration is present.
 - Do not install insulation on any part of the actuator.
-

Mounting

Caution: Do not twist or exert any force on the actuator housing during installation. Either turn the base by hand or, if necessary, use a 1-5/8" open-ended wrench (TOOL-37) on the flats provided on the actuator base or the valve body mounting nut (refer to Figure-4).

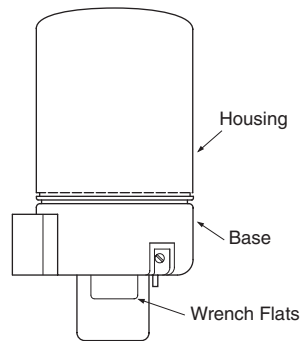

Figure-4 Housing and Base Location.

Dampers

The actuator is not position sensitive. It can be mounted in any position in a NEMA Type 1 location.

Valves

Allow 3" (76 mm) of clearance above the actuator valve assembly for the removal and reattachment of the actuator to the installed valve.

1. Install all two-way valves so that they close against the flow. An arrow on the valve body or tag indicates proper flow direction.
2. Always install three-way mixing valves with two inlets and one outlet.
3. Always install three-way diverting valves with one inlet and two outlets.

Caution: For steam applications only, mount the actuator above the valve body at 45° from vertical.

4. Actuators can be mounted in any upright position above the centerline of the valve body.

Wiring Requirements

Control Leads

The control leads may be connected to a Class 2 circuit if routed separately from Class 1 circuit wiring. Refer to Figure-8.

Refer to Table-4 for control lead colors and Table-5 for maximum wire run.

Table-4 Control Wiring Color Codes.

Description	Wire Color
Retract	White/Green
Extend	Violet
24G	Black/Blue
24H	Black
15K Feedback - Retract	White/Orange
15K Feedback - Extend	White/Brown
15K Feedback - Wiper	White/Blue

Caution:

- Use three-conductor, twisted, shielded wire when it becomes necessary to install the control leads in the same conduit with power wiring or when RFI/EMI generating devices are near.
Do not connect shield or conduit to earth ground.

Table-5 Control Wiring Data, Violet and White/Green Wires Only.

Wire Size GA	Maximum Wire Run (5% Voltage Drop) ft. (m)
18	110 (33)
16	175 (53)
14	280 (85)
12	444 (135)

Power Leads

The low voltage (24 Vac) power leads may be connected to a Class 2 circuit if routed separately from Class 1 circuit wiring. Refer to Figure-8. Refer to Table-6 for maximum length of run for given wire size(s).

To determine the allowable maximum power lead run for multiple actuator wiring, divide the maximum run shown in Table-6 by the number of actuators on the run.

Table-6 Power Wiring Data.

Actuator Voltage Vac	Actuator Model Number	Power Lead Colors	Max. Wire Run (5% Voltage Drop) ft. (m)	
			14 AWG	12 AWG
24	MF-5413	Black Black/Blue	280 (85)	444 (135)
	MF-5413-500			
	MF-5433			
	MF-5513			
	MF-5513-500			
	MF-5533			

Auxiliary Switch Leads

The low voltage (24 Vac) auxiliary switch leads may be connected to a Class 2 circuit.

The line voltage (120 Vac and 240 Vac) auxiliary switch leads must be connected to a Class 1 circuit and routed separately from any Class 2 circuit wiring. Refer to Figure-8.

Wiring Connections

Wire Lead Connections (No Conduit)

Make connections as required. Refer to Figure-5.

Note: Cover plate and screws supplied with actuator are not required.

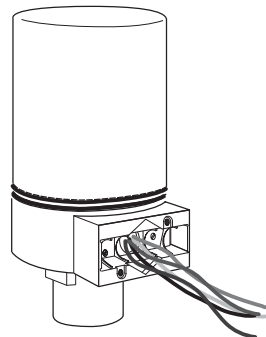

Figure-5 Wire Lead Connection (No Conduit).

Install 3/8" reduced (thin) wall flexible metal conduit onto one or both sides of actuator.

Flexible conduit may be installed onto one or both sides of the actuator. Refer to Figure-7 and Figure-8. Install each conduit as follows:

1. Determine the side of the actuator to which the flexible conduit is to be attached.
2. Remove the knockout, using channel lock pliers, on the selected side of the actuator. Refer to Figure-6.
3. Make the required connections. Refer to Figure-1 for a wiring diagram of a typical application. Refer to Figure-2 for a wiring diagram of the 18K feedback potentiometer for the MF-55X3 model series actuators. Refer to Figure-3 for a wiring diagram of the auxiliary switch for MF-5X13-500 model actuators.

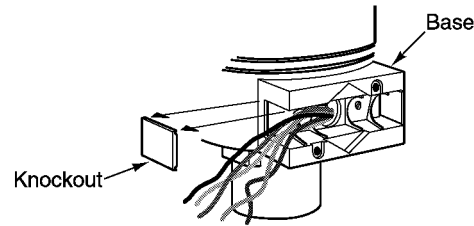

Figure-6 Removal of Knockout on Actuator Base.

4. Slip the conduit onto the base, over the ribs. Refer to Figure-7 and Figure-8.
5. Install the cover plate with two screws. The cover plate and two screws are supplied with the actuator.
6. If flexible conduit is to be installed on both sides of the actuator, repeat the preceding steps to install the second conduit.

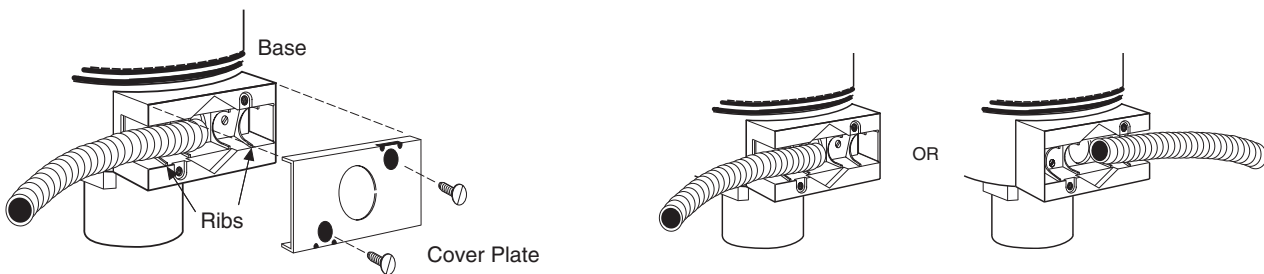

Figure-7 Flexible Conduit Installation to Either Side of Actuator.

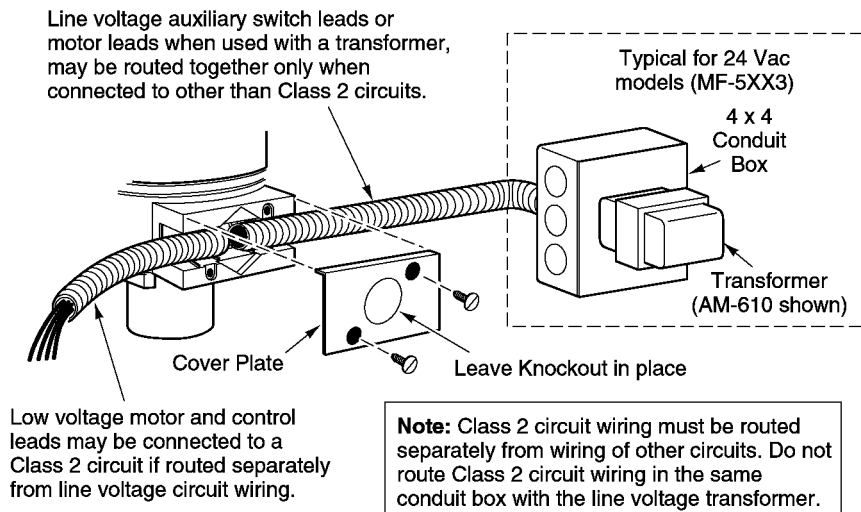

Figure-8 MF-5XX3 Series Wiring with Separation for Class 2 and Line Voltage Circuits.

Install reduced (thin) wall flexible metal conduit directly to actuator.

1. Remove the knockout from the cover plate supplied with the actuator. Refer to Figure-9.

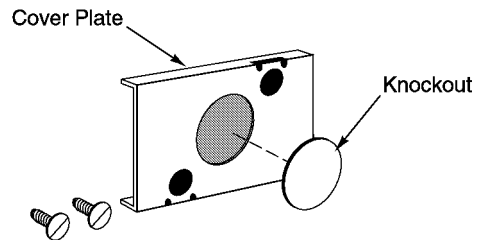

Figure-9 Cover Plate Knockout Removal.

2. Slip the leads through a standard 1/2" conduit bushing (not supplied) and the knockout hole in the cover plate. Refer to Figure-10 and Figure-11.

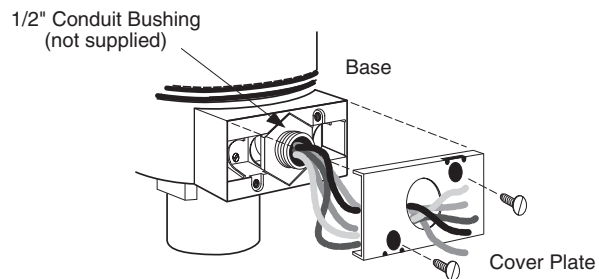

Figure-10 Conduit Bushing and Cover Plate Installation.

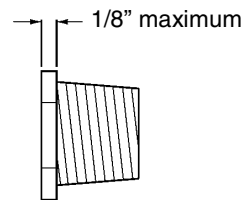

Figure-11 1/2" Conduit Bushing.

3. Nest the conduit bushing in the base.
4. Install the cover plate, using the two screws provided.
5. Make the required connections. Refer to Figure-1 for a wiring diagram of a typical application.
6. Attach the flexible conduit to the conduit bushing, as required.

Install conduit box to actuator.

1. Remove the knockout from the cover plate supplied with the actuator. Refer to Figure-6.
2. Slip the leads through a standard 1/2" conduit bushing (not supplied) and the knockout hole in the cover plate. Refer to Figure-9 and Figure-10.
3. Nest the conduit bushing in the base.
4. Install the cover plate, using the two screws provided.
5. Attach the conduit box to the threaded adaptor.
6. Make the required connections. Refer to Figure-1 for a wiring diagram of a typical application.
7. Install the rigid conduit, the flexible conduit, etc. to the conduit box as required. Refer to Figure-12.

Note: As shown in Figure-10, the hole in the cover plate of the actuator conduit housing is sized to accept both British standard M20 (20 mm) conduit connectors and 20 mm-to-PG16 adaptors for use with DIN PG16 connectors. (Follow the steps for installing the conduit box to the actuator.)

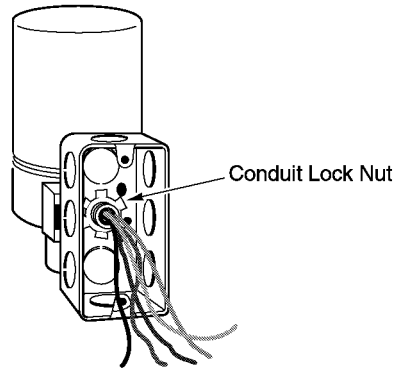

Figure-12 Attachment of Conduit Box to Threaded Adapter.

Linkage Assembly

Damper

Note: Each actuator in the MF-5X33 series is provided with a factory-installed damper linkage. No separately-ordered linkage is required.

Caution: Do not twist or exert any force on the actuator housing during installation. Either turn the base by hand or, if necessary, use a 1-5/8" open-ended wrench (TOOL-37) on the flats provided on the actuator base, or on the valve body mounting nut. Refer to Figure-4.

1. Determine the best mounting position for the actuator as follows:
 - a. Determine, from the system requirements, if the damper should spring-return to the open position (refer to Figure-13) or closed position (refer to Figure-14) whenever power is lost to the actuator. An actuator is normally linked so as to retract (spring-return) to the dampers fully open position (heat position).
 - b. Be sure to allow adequate working space around the actuator mounting location to mount the actuator, link it to the damper, and wire it into the system (refer to Figure-15).
 - c. If possible, select a mounting position such that, at mid-stroke, the actuator crank arm and the damper crank arm on the drive shaft are each at a 90° angle to the damper rod (refer to Figure-15). This is the recommended mounting position. It may be necessary to swivel the actuator linkage to arrive at this mounting location.
 - d. Consider the damper rod length when positioning the actuator in relation to the damper. A damper rod that is too long is not rigid enough to provide good control, while a damper rod that is too short makes adjustment difficult.

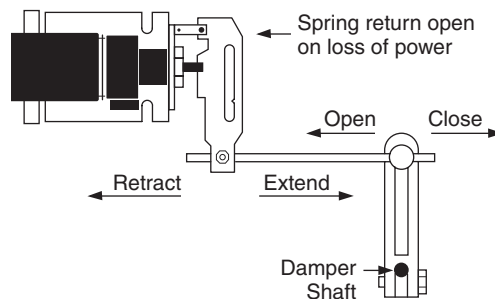

Figure-13 Dampers Open When Actuator Retracts (Spring Return Opens on Power Loss).

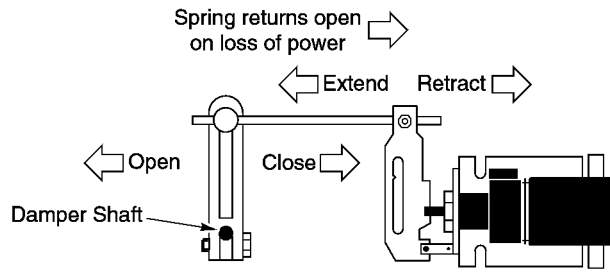

Figure-14 Dampers Open When Actuator Extends (Spring Return Closes on Power Loss).

- Position the actuator on the duct and mark the location of the mounting holes, using the actuator mounting bracket as a template. Refer to Figure-15.

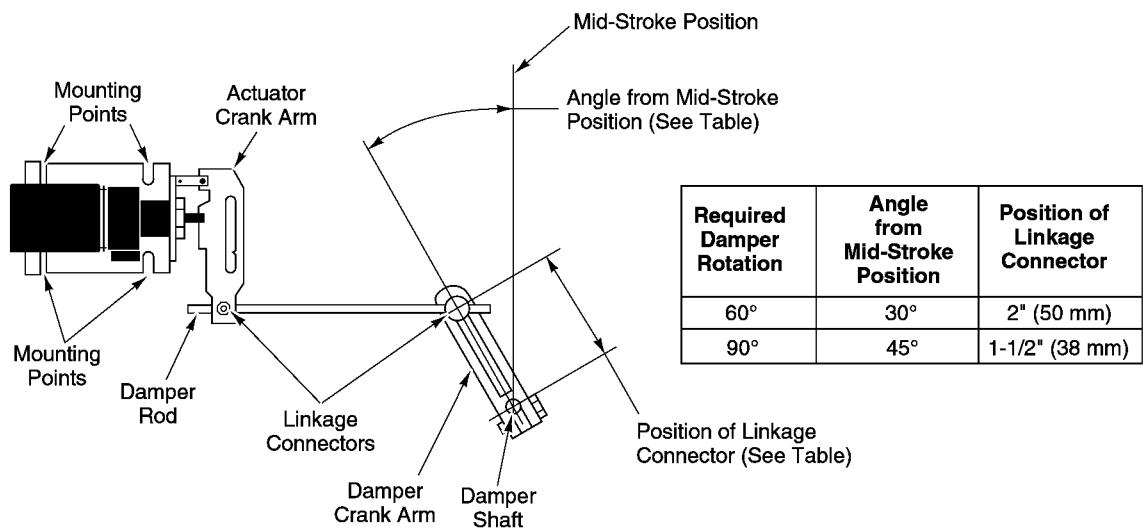

Figure-15 Recommended Actuator/Damper Mounting.

- Drill or punch the mounting holes in the duct for the appropriate 1/4" (6 mm) diameter screws or bolts. The actuator must be mounted firmly enough to prevent excessive actuator movement under normal damper loading. If there is excessive actuator movement, the damper may not fully open or close.
- Mount a ball joint connector in the slot on the damper crank arm. To achieve 90° of damper rotation, position the connector 1-1/2" (38 mm) from the centerline of the shaft hole on the crank arm. For 60° of damper rotation, position the connector 2" (50 mm) from the shaft hole centerline. Typically, 60° to 70° of rotation (maximum is 90°) is sufficient to permit almost maximum air flow through the dampers. Refer to Figure-13.
- Rotate the damper to its open position. Install and secure the damper crank arm (with ball joint connector) to the damper shaft, positioning the crank arm as follows (refer to Figure-13):
 - To achieve 60° of damper rotation, position the crank arm so that it is pointed towards the actuator at 30° from its mid-stroke position.
 - To achieve 90° of damper rotation, position the crank arm so that it is pointed towards the actuator at 45° from its mid-stroke position.
- Install the damper rod by sliding one end through the ball joint connector mounted on the damper crank arm, and the other end through the straight connector on the actuator crank arm. Tighten the nut on the actuator crank arms straight connector. Cut off any excess length of damper rod.
- For normally open dampers, tighten the nut on the ball joint connector on the damper crank arm. To ensure that the damper closes completely, make adjustments so that the actuator

is 1/16" (1.6 mm) from the extended end of stroke when the damper closes. Verify and, if necessary, make final adjustments during system checkout.

8. For normally closed dampers, rotate the damper crank arm until the damper is closed. While holding the damper closed, tighten the nut on the ball joint connector on the damper crank arm. To ensure that the damper closes completely, make adjustments so that the actuator is 1/16" (1.6 mm) from the retracted end of stroke when the damper closes.

Final adjustment of the actuator and damper must be performed when the system is powered and functioning. Refer to the CHECKOUT section to ensure that the damper is linked correctly.

Valve

For valve assembly details refer to AV-600 and AV-601 General Instructions, F-19069. Refer to Figure-18 for external dimensions for the valve actuator.

Adjustments

Auxiliary Switch for MF-5X13-500 Series

The switching point is adjustable over the entire actuator stroke and is pre-set at the factory to close the N.C. contact 1/8" from the full retracted end of stroke. The total stroke of the actuator is 9/16". Each complete turn of the switch adjustment screw moves the switching point 0.1". Use TOOL-12 to turn the switch adjustment screw CW until the switch operates at desired stroke from the retracted position. Refer to Figure-16 for location.

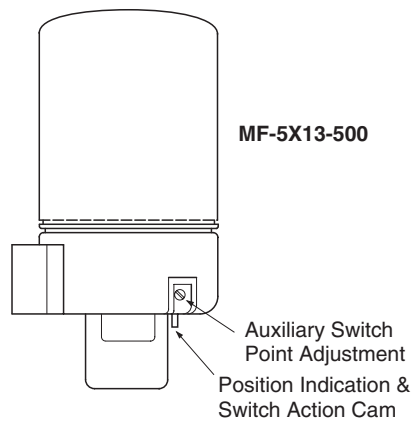

Figure-16 Auxiliary Switch Point Adjustment and Position Indication Locations.

CHECKOUT

After the entire system has been installed and the actuator has been powered up, perform the following checks for proper system operation.

Caution: Never power the actuator without a spring return linkage attached.

Positioning with Controller

If the sensed media is within the controller's setpoint range, the actuator can be positioned by adjusting the controller setpoint up and down. Check for correct operation of the actuator (valve or damper) while the actuator is being stroked.

Go, No-Go Test

1. Apply power to the actuator. The actuator motor should run and the actuator shaft should extend.
2. Remove power from the actuator. The actuator motor should stop running and the actuator shaft should spring return to the retracted position.

MAINTENANCE

The actuator is sealed in oil and requires no maintenance.

Regular maintenance of the total system is recommended to assure sustained, optimum performance.

TROUBLESHOOTING

Use the following steps to locate malfunctions:

1. Check the actuator by applying the proper supply voltage.
2. The motor should run when power is applied. If it does not run, the actuator is inoperative and should be replaced.
3. While the motor is running, the actuator should extend. If it does not extend, check the mechanical linkage for any damage or misadjustment which could prevent the actuator from extending. If the mechanical linkage is inoperative, adjust the linkage or replace the damaged components, as applicable. If the mechanical linkage moves correctly and freely, the problem lies in the actuator and it must be replaced.
4. If applying power directly to the actuator results in correct operation of the actuator, the actuator and linkage are functional, and the problem lies in the wiring or thermostat. Repair or replace the wiring or thermostat, as applicable.

FIELD REPAIR

None. Replace an inoperative actuator with a functional unit.

DIMENSIONAL DATA

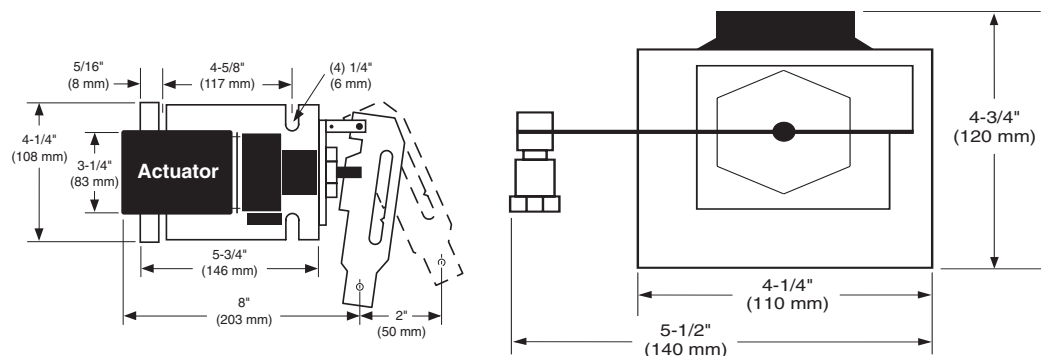

Figure-17 Damper Linkage Assembly Dimensions.

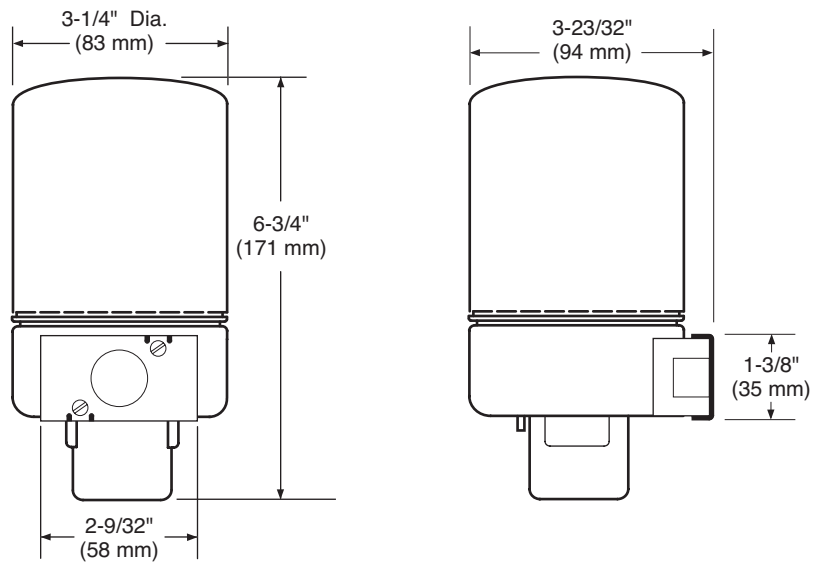

Figure-18 Actuator Dimensions.

Copyright 2006, TAC
All brand names, trademarks and registered
trademarks are the property of their respective
owners. Information contained within this
document is subject to change without notice.

TAC
1354 Clifford Avenue
P.O. Box 2940
Loves Park, IL 61132-2940

F-24696-3



www.tac.com

