

**Electronic Programmable Controllers**  
**Six Stage**  
**General Instructions**

**APPLICATION**

The six stage electronic programmable controllers provide proportional control of outside and return (mixed air) dampers in sequence with staged heating and cooling equipment. Programming of the heating and cooling stages and relay assignment of heating and/or cooling plus operating level are accomplished by dual-in-line package (DIP) switches. Proportional heating and cooling outputs are available for valves or electric heat coils. The six stages can be programmed for heating, cooling, humidification, night setback and fan operation.

The heating, cooling and ventilation are precisely controlled from a single sensor operating with the programmable controller which employs a single temperature setpoint. (The CP-8261-333 setpoint is concealed while the CP-8261-702 setpoint is exposed). A nullband adjustment is also provided for separating the heating and ventilating/cooling functions between 2 and 14°F. Fan operations may be programmed to cycle in the unoccupied mode.

**SPECIFICATIONS**

**Sequenced Control:** Staged and/or proportional heating, proportional control of outside and return (mixed air) damper, staged and/or proportional cooling. Heating and cooling cannot operate simultaneously.

**Single Setpoint (SPB):** 55 to 85°F (13 to 29°C). Heating, cooling and ventilation are controlled from a single sensor and a single setpoint.

**Nullband Adjustment (SPA):** 2 to 14°F (0 to 8°C); factory set at 3°F (2°C). Provides for separating the heating and ventilation/cooling.

**Mixed Air Low Limit Setpoint (SPC):** 41 to 95°F (5 to 35°C).

**Relay Rating:** 24/120 Vac, 1 amp. 240 Vac, 0.5 amp inductive. See Table 1.

**Adjustments:** (For other adjustments See Table 2).

**Minimum Position,** Minimum mixed air damper position (0 to 100%) factory set at 25%.

**Mixed Air Start Point,** Factory set OP3 is 9 Vdc when IO2 is at 6 Vdc. The M.A.S.P. can be adjusted so that OP3 is 9 Vdc when IO2 is 3 Vdc.

**Unit Fan:** May be programmed to cycle in the unoccupied mode.

**Relay Output:** 6 relays can be programmed for heating, cooling or fan operation. Operational voltage level by dual-in-line switches.

**Mixed Air Sensor (optional):** The controller can provide a separate mixed air control, or limit control in conjunction with proportional cooling output ramp.

**Cold Start:** On power failure.

**Sensors:** Any non-adjustable TS-8000.

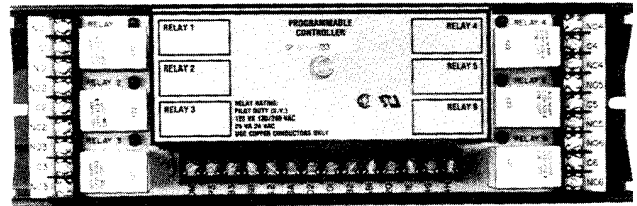

CP-8261-333

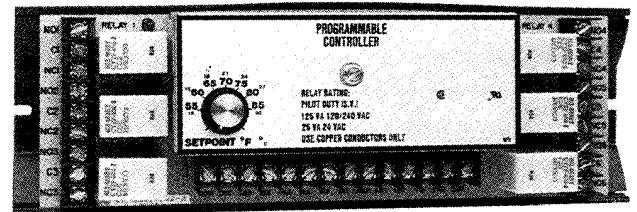

CP-8261-702



**Control Output Voltage:** See Table 2.

**Power Requirements:** 24 Vac, 10 VA.

**Power Supplies Available:** 6.2 Vdc, 4 mA; 20 Vdc, 35 mA.

These regulated and filtered power supplies must not be connected to +20, +6.2 or red lead of other supplies.

**Environment:**

**Ambient Temperature Limits,**

**Shipping and Storage -40 to 160°F (-40 to 71°C).**

**Operating 0 to 140°F (-18 to 60°C).**

**Humidity, 5 to 95% RH, non-condensing.**

**Locations, NEMA Type 1 indoor only.**

**Connections:** Coded screw terminals.

**Cover:** Aluminum.

**Mounting:** Unit is provided with plastic track for panel mounting.

**Dimensions:** 3-7/8" high x 12" wide x 2-3/4" deep (98 mm x 305 mm x 70 mm).

**Table-1 RELAY CONTACT RATINGS.**

Volts AC 50/60 Hz	Contact	VA Rating	Inrush VA
120/240	N.O.	125	1250
	N.C.	67	670
24	N.O.	25	250
	N.C.	13	130

**ACCESSORIES**

- AD-8969-201 Offset resistor kit; 5, 10, 15, and 20°F
- AT-8122 Remote setpoint adjuster, dual scale 20 to 120°F (-6 to 49°C)
- AT-8155 Remote setpoint adjuster, dual scale 50 to 250°F (10 to 120°C)
- AT-8158 Remote setpoint adjuster, dual scale 55 to 85°F (13 to 29°C)
- AT-8258-101 Night setback scale for AT-8158
- TC-4111 Bulb thermostat
- THC-2 Enthalpy controller
- TS-8101 Room sensor
- TS-8131 Room button-type sensor
- TS-8201 Duct/immersion sensor
- TS-8241 Diffuser sensor
- TS-8261 Light fixture sensor

- TS-8405 5' (1.5 m) averaging sensor
- TS-8422 22' (6.7 m) averaging sensor
- TS-8501 Outdoor sensor
- TS-8601 Selective ratio discharge sensor
- TSP-8101-103 Temperature transmitter
- TOOL-201 Calibration kit for TAC System 8000

**Table-2 SPECIFICATIONS.**

Setpoint Range °F (°C) (SFB)	Nullband Range °F (°C) (SPA)	Mixed Air Low Limit Setpoint °F (°C) (SPC)	Throttling Range Adjustments °F (°C)			Proportional Outputs			Staged Heat and/or Cool Output Relays
			Heating (TRA)	Cooling (TRB)	Mixed Air	Heating (IO1)	Cooling (IO2)	Mixed Air OP3)	
55 to 85 (13 to 29)	2 to 14 (1 to 8) Factory set for 3 (2)	41 to 95 (5 to 35)	2 to 10 (1 to 5) Factory set for 3 (2)	2 to 10 (1 to 5) Factory set for 3 (2)	10 (5) Fixed	2 to 15 Vdc Direct Acting or 15 to 2 Vdc Reverse Acting (jumper select)	2 to 15 Vdc Direct Acting ONLY	5 to 12 Vdc Direct Acting ONLY	0 to 6 Relays DIP switch selectable for any combination of Heat and/or Cool

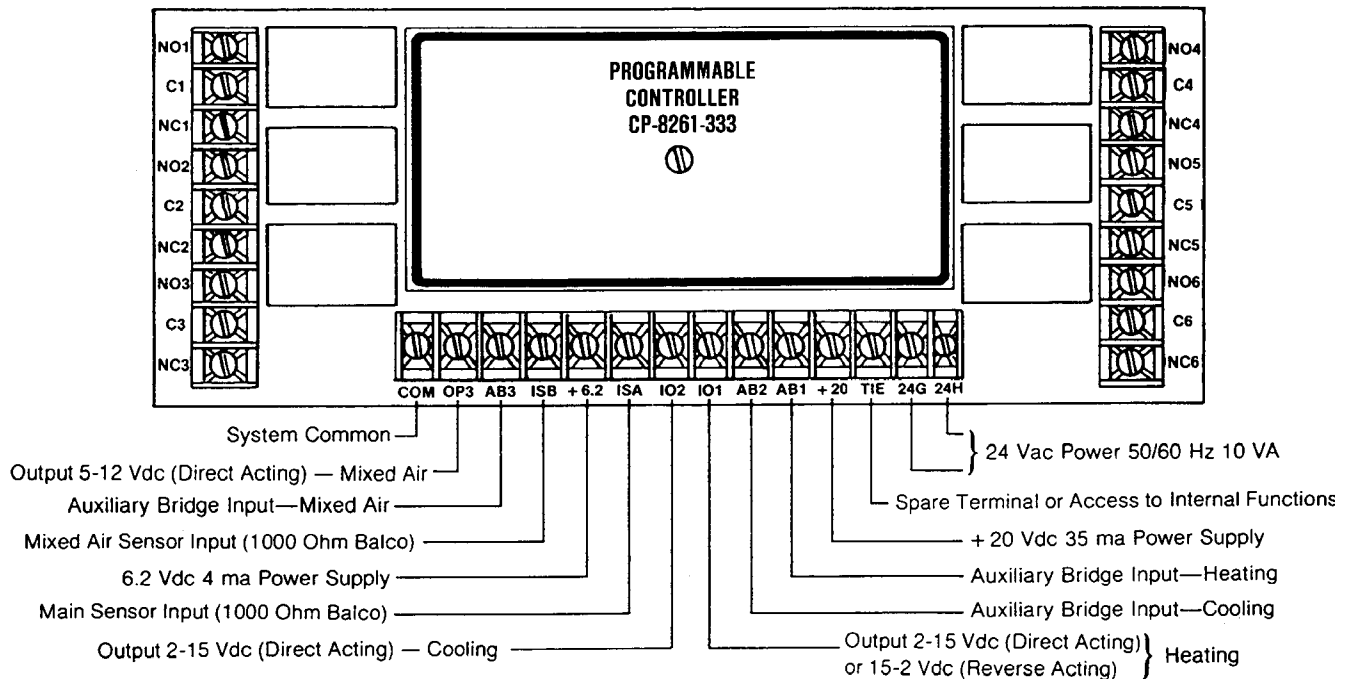

**DEFINITIONS**

**Direct Acting (D.A.) Control** Temperature increase at main temperature sensor causes the output voltage signal to increase, therefore causing the relays to energize.

**Reverse Acting (R.A.) Control** Temperature increase at main temperature sensor causes the output voltage signal to decrease, therefore causing the relays to de-energize.

**Throttling Range (T.R.)** Number of degrees change required at the main temperature sensor in order to produce a 6 to 9 Vdc (3 Vdc) proportional signal output change.

Figure-1

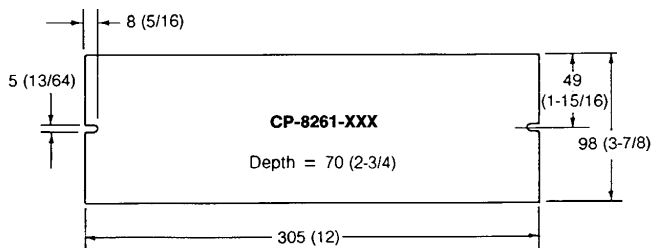

All dimensions in millimeters with inches shown in brackets.

Figure-2

## INSTALLATION

Mount the device in an inside location near the controlled equipment using the two slots in the track. Avoid locations where excessive vibration, moisture, corrosive fumes or vapors are present, or where high radio frequency or electromagnetic interference generating devices are near. NEMA Type 1 housings are intended for indoor use primarily to provide a degree of protection against contact with the enclosed equipment.

See Figure 2 for mounting dimensions.

## PRE-INSTALLATION

Visually inspect the package for damage. If damaged, notify the appropriate carrier. Visually inspect the device for obvious defects. Return damaged or defective products.

Mounting screws are not provided.

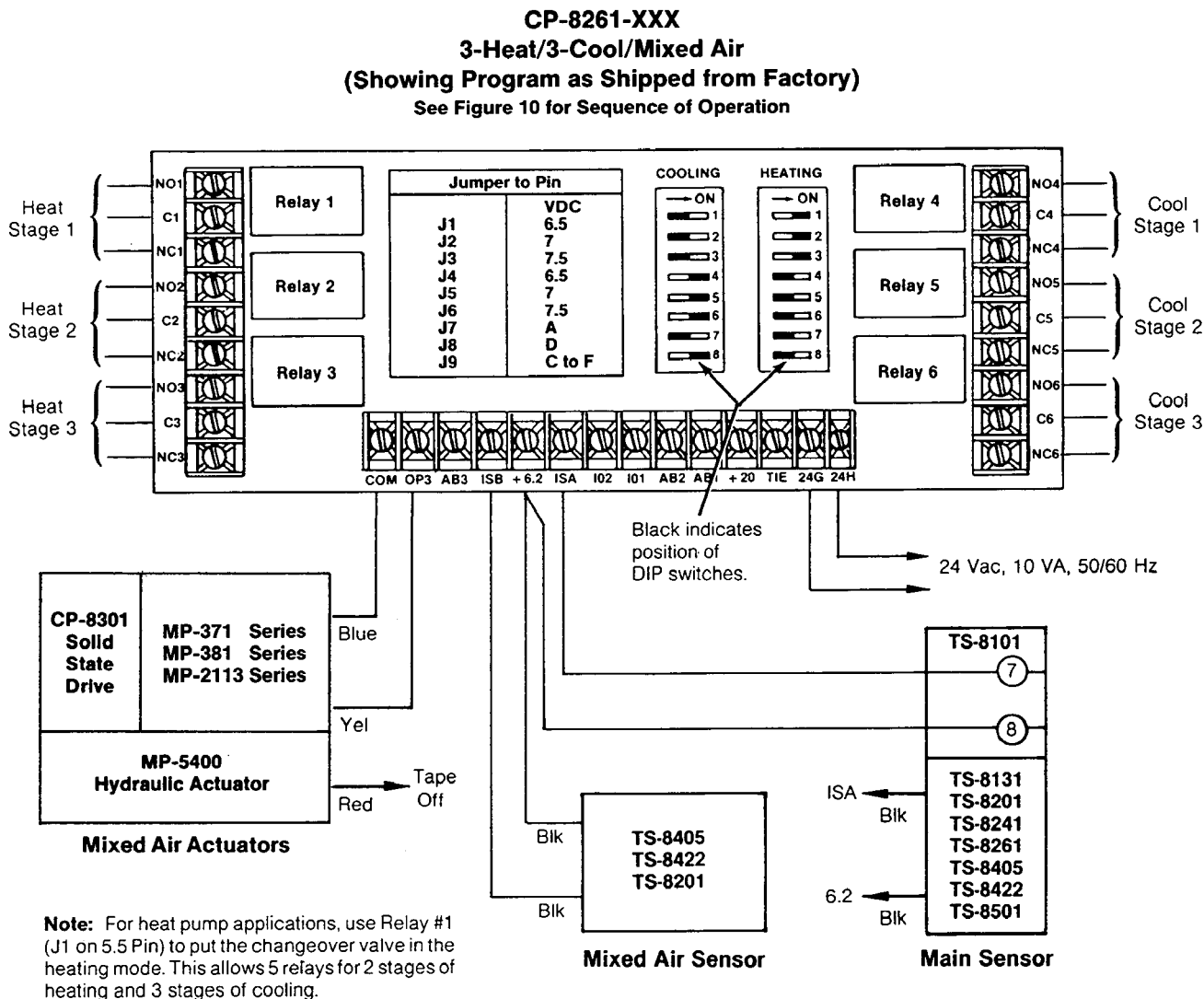

Figure-3

## WIRING

Make all connections according to job wiring diagrams and in compliance with national and local codes.

All circuits must be wired NEC Class 1 unless only one CP-8261 with all low voltage (under 30 Vac) connections is used in the enclosure.

Two separate No. 18 twisted pair wires (six turns per foot), low voltage, are suitable for up to 1000 feet for the sensor leads.

When more than one programmable controller is used in the same enclosure, one Class 2 transformer with proper VA rating should be used to power all programmable controllers.

Never run line voltage in the same conduit with unshielded sensing element leads.

Shielded cable must be used when it is necessary to install the DC signal leads in the same conduit with power wiring, or when it is known that high RFI/EMI generating devices are near. Terminate the shield at the controller only on the COM (-) terminal.

**Caution:** Never connect the shielding or common to earth ground.

Refer to the wiring diagram (Figure 3) for typical connection to power, inputs and outputs required by the application.

## OPERATIONAL DATA

The general operational capability of the programmer is explained on page 12 in Theory of Operation.

### Control Arrangements

The instructions are provided for three applications of staged control arrangements plus input and output options, as follows:

1. A staged 3 heat/3 cool/mixed air application is shown in Figure 3. As an option, position 8 on the cooling DIP switch can be placed in the "off" position. This will provide a true mixed air controller, and the mixed air will be maintained at the temperature set on the mixed air low limit setpoint. Turn the mixed air start point adjustment full clockwise to disable.
2. A staged 3 heat/2 cool/fan cycle/mixed air application is shown in Figure 8.
3. A staged 2 heat/2 cool/humidification/dehumidification is shown in Figure 9.

### Optional Inputs and Outputs

Figures 4 and 5 show the application of optional control inputs and outputs.

### Optional Inputs

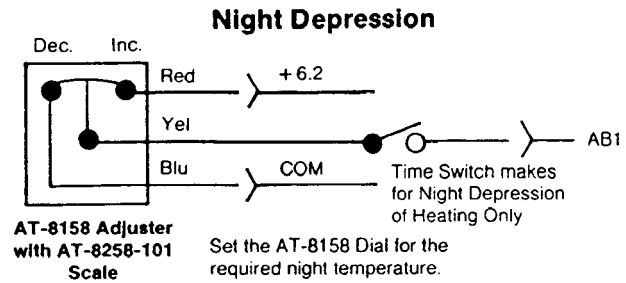

### Remote Setpoints

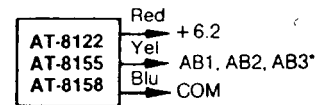

**CP-8261-XXX Settings**

**\*Note: CP-8261-333 Settings**

- AB1 (Heat) Turn SPA to 70°
  - AB2 (Cool) Turn SPB to 70°
  - AB3 (Mixed Air) Turn M.A. Lo Limit to 70°
- When the AT-8100 Series R.S.P.A. are required, 2 or 3 are used.

### Ratio Discharge Control (Heating Only)

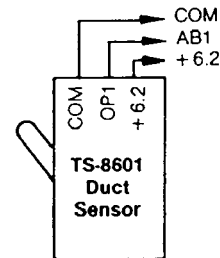

**Note: Heating Only**

### Outside Air Temperature or Enthalpy Override

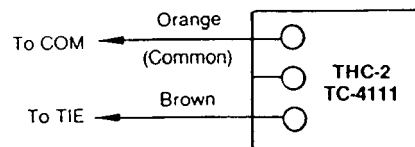

Orange breaks from brown on an increase in temperature or enthalpy to cause an override condition.

**Note: CP-8261-333 Settings**

- Jumper Pin F to Pin C (factory set)
- Place Jumper J8 to Pin H

Figure-4

## Optional Outputs

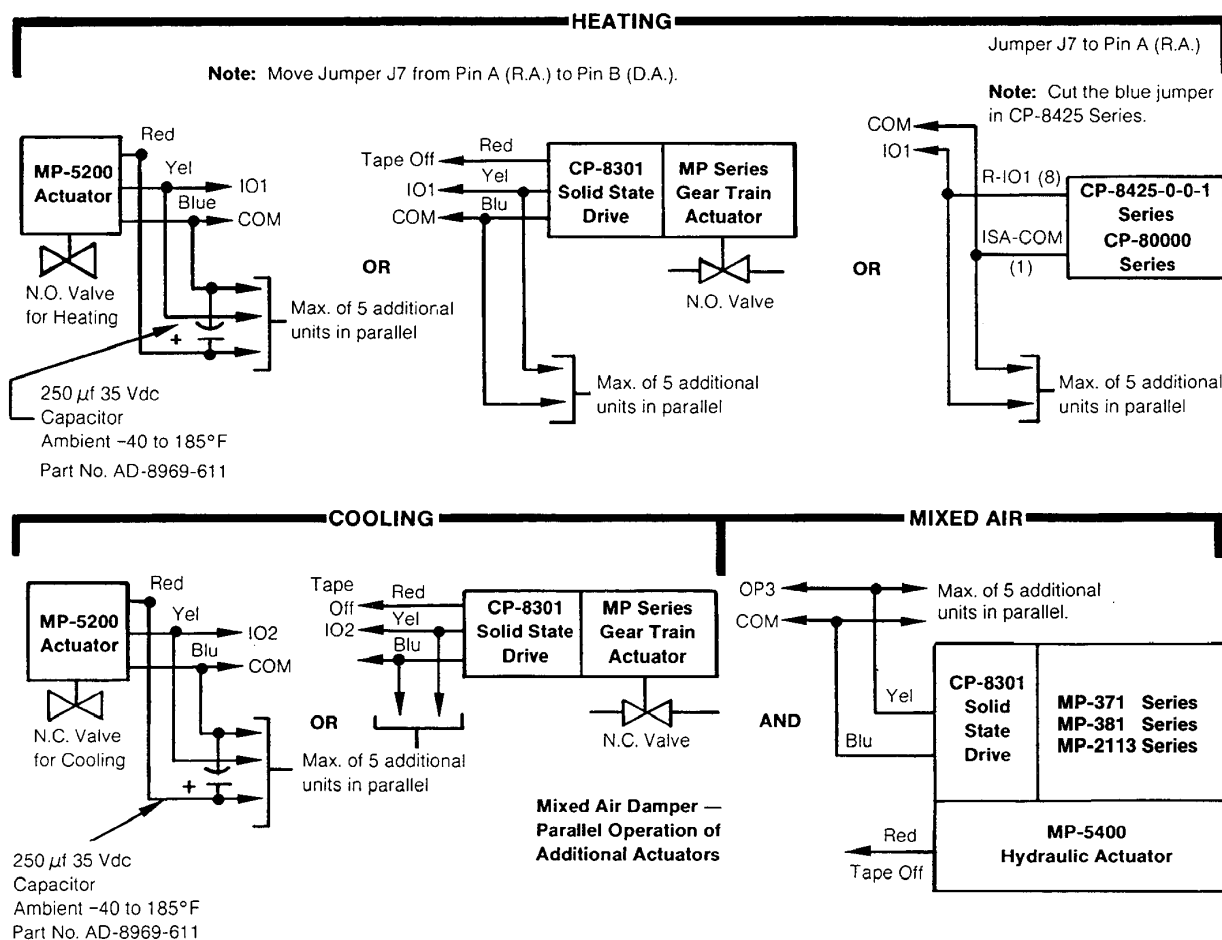

Figure-5

### OPTIONAL INPUTS

- Night depression (adjustable).
- Remote setpoints of heating, cooling and mixed air temperature.
- Ratio discharge control for heating.
- Outside air temperature or enthalpy override of the mixed air damper control to minimum ventilation when the outside air cannot cool.
- Separate heating and cooling setpoint adjusters at the sensing location.

### OPTIONAL OUTPUTS

- Heating  
Hydronic valve control.  
SCR electric heat control, single or 3 phase power.
- Cooling with chilled water valves.
- Mixed air damper control with additional actuators in parallel.
- Slaving up to five additional programmable controllers for parallel operation.
- Heating and cooling lockout.

### Jumper/Pin Programming Functions

The programmable controller block diagram, sequence of operating voltage signals and jumper/pin programming instructions are shown in Figures 10 and 11. Jumper/pin programming provides the following functions:

- Relay selection: The Vdc pins designate the pull-in voltage (via jumpers 1 to 6) that is measured at terminals IO1, IO2 and COM.
- Heating voltage signal ramp; i.e., reverse or direct acting (J7 to pin A or B).
- Mixed air override to minimum ventilation by cooling stage 1 or 2 (J8 to pin D or E) or by external outdoor air enthalpy or temperature (J8 to pin H and black jumper on pins F and C).

### Heating and Cooling DIP Switches

The programming instructions for the heating and cooling DIP Switches are shown in Figure 11. The DIP switches program the relays for heat, cool or fan operation and select the mixed air operating cycle.

## Jumper/Pin and DIP Switch Programming

The jumper/pin and DIP switch programming makes it possible to provide:

- An economizer mixed air cycle in conjunction with -  
Up to 6 stages of heat or cool.  
Any combination of heat and cool stages.  
Any combination of heat and cool stages plus a unit fan stage.  
Proportional output signals for control of heating valves, cooling valves and SCR electric heat control.
- Multiple cycles, such as 2 heat and 2 cool stages with humidification and dehumidification stages.
- A mixed air cycle with adjustable minimum ventilation which operates independently of the heating and cooling program. The mixed air temperature may be set in the range of 41 to 95°F by the mixed air low limit adjuster.

## Nullband

The nullband between heating and cooling is the difference in the SPB and SPA settings. For example, the nullband is 13°F when SPB is set at 75° and SPA is set at 65°F.

## Mixed Air Start Point

The point at which the mixed air cycle starts to operate in the heat and cool program is adjustable by using the mixed air start point (MASP). Turn the MASP adjuster clockwise to increase the nullband between free cooling and operation of the cooling equipment.

The mixed air operating throttling range is the setting of TRB when controlled from the cooling ramp signal. When the mixed air temperature is 5° above the mixed air low limit setting, the mixed air damper is positioned directly by the mixed air ramp signal. The mixed air low limit control has a 10°F fixed throttling range.

If the mixed air temperature approaches the low limit setting, the low limit proportions the outside air damper fully closed (or minimum ventilation position) 5°F below the setpoint, and allows full opening of the outside air damper 5°F above the setpoint.

The adjustment and programming locations are shown in Figure 13.

## OPERATION

The CP-8261 is factory set to provide 3 stage heat/3 stage cool/mixed air cycle program. Refer to Figure 3.

When the space temperature drops below its setpoint (SPB typically 75°F), the controller provides up to 3 stages of heat (or will proportion an SCR electric heat control) to maintain the SPB setting. The mixed air is in the minimum damper position setting for ventilation.

When the space temperature approaches the setpoint (SPB typically 75°F), the mixed air dampers are proportioned to provide maximum cooling from the outside air. The dampers are proportioned to the minimum ventilation position if the mixed air temperature approaches the low limit setting.

When the outside air cannot provide enough cooling, the controller provides 3 cooling stages (or will proportion chilled water valves) to maintain the SPB setting.

The mixed air is returned to the minimum damper position when the first stage of cooling is energized. (See programming instructions for other options). For applications requiring other combinations of heat and cool stages, simply select the staging relays by using the programming instructions for the heating/cooling DIP switches and jumpers.

## Examples:

*For a 4 stage heat/2 stage cooling application* use factory settings but set switch 4 of the heating DIP to "on" and set switch 4 of the cooling DIP to "off". Relays 1 through 4 will then be heating relays. The throttling range of heating remains 3°F unless changed by adjusting TRA or TRB. Place jumper J4 on pin 8.

*For 6 stage cooling application* set switches 1 through 6 of the heating DIP to "off" and set switches 1 through 6 of the cooling DIP to "on". The throttling range remains 3°F unless changed by adjusting TRB. Place jumper J4 on pin 8, J5 on pin 8.5 and J6 on pin 9. SPA can still be the setpoint for proportional heating.

*For 6 stage heating application* set switches 1 through 6 of the heating DIP to "on" and set switches 1 through 6 of the cooling DIP to "off". The throttling range remains 3°F unless changed by adjusting the TRA. Place jumper J4 on pin 8, J5 on pin 8.5 and J6 on pin 9. Set SPA at 65°F, for example. The cooling ramp has control of the mixed air. (Cooling switch 8 must be on). To start to open the mixed air for cooling, set SPB at 70°F. When TRB is set at 5°F, the mixed air cycle will start at 65°F (at 0% minimum). The mixed air cycle will start at a temperature of the SPB setting minus the TRB setting.

*When an air supply fan stage is used* (Figure 8), the fan is "off" in the program nullband. On a call for staged or proportional heating or cooling, the fan starts first. When the fan stage is used, the fan must always be running while electric heat or direct expansion cooling is energized.

*For heat pump applications* relay 1 controls the unit changeover valve. See the heat pump note in Figure 3.

*For systems without a mixed air cycle and with multiple cycle operation* (Figure 9), the room temperature is maintained without a mixed air cycle. The relative humidity is typically maintained in the range of 40% to 55% Rh. Humidity control is maintained by relays 5 and 6 which are controlled by the mixed air controller section and a humidity sensor.

*Blank charts are provided* inside the cover to record the application jumper/pin and DIP switch for reference in future service work.

## HEATING, COOLING LOCKOUT

Lockout stages of heating or cooling are accomplished by breaking the lead from the relay common terminal to the controlled device with a relay or switch. See Figure 6.



**CP-8261-XXX**  
**3-Heat/2-Cool/Fan Cycle/Mixed Air**

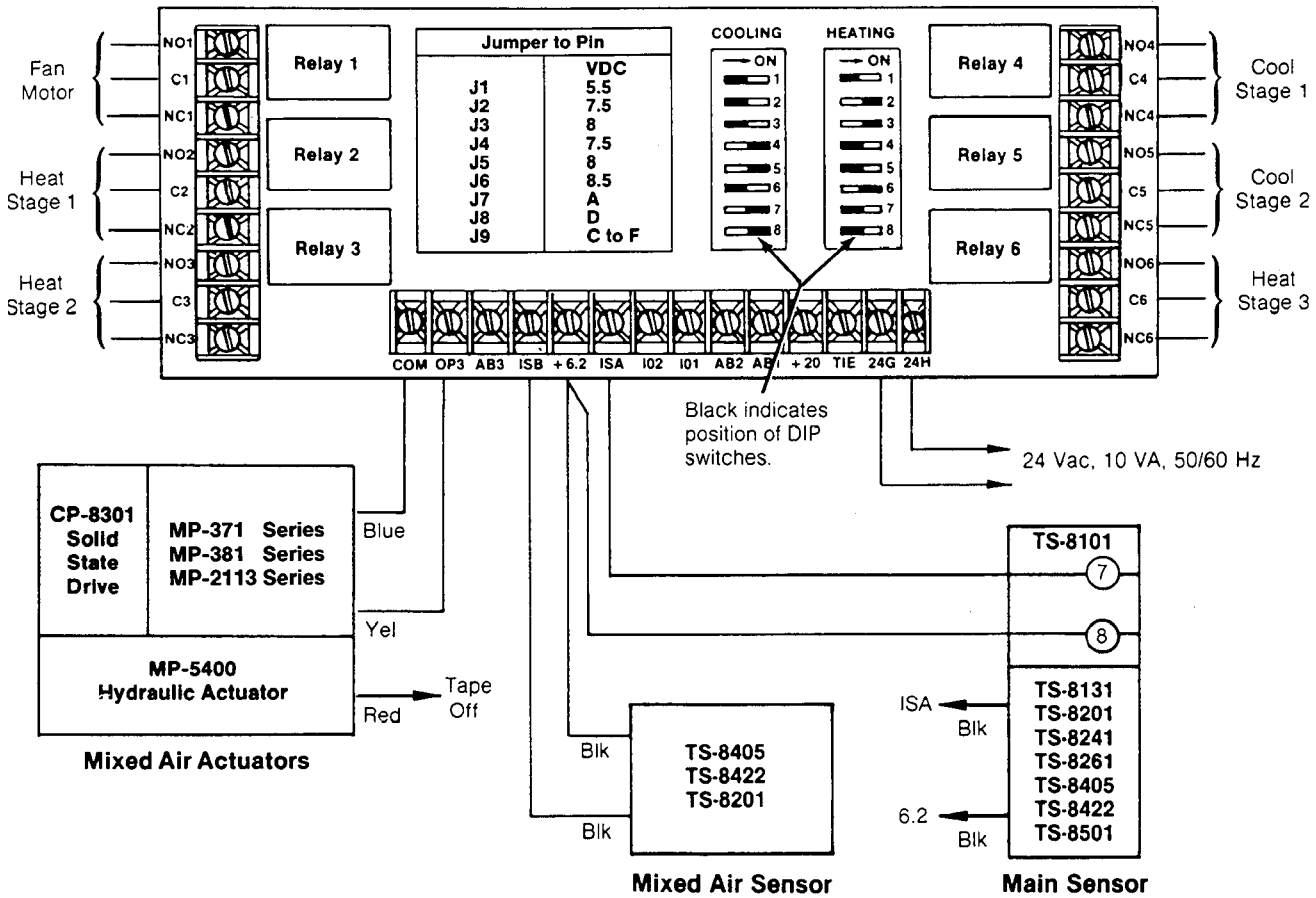

Figure-8

**CP-8261-XXX**  
**2-Heat/2-Cool/Humidification/Dehumidification**

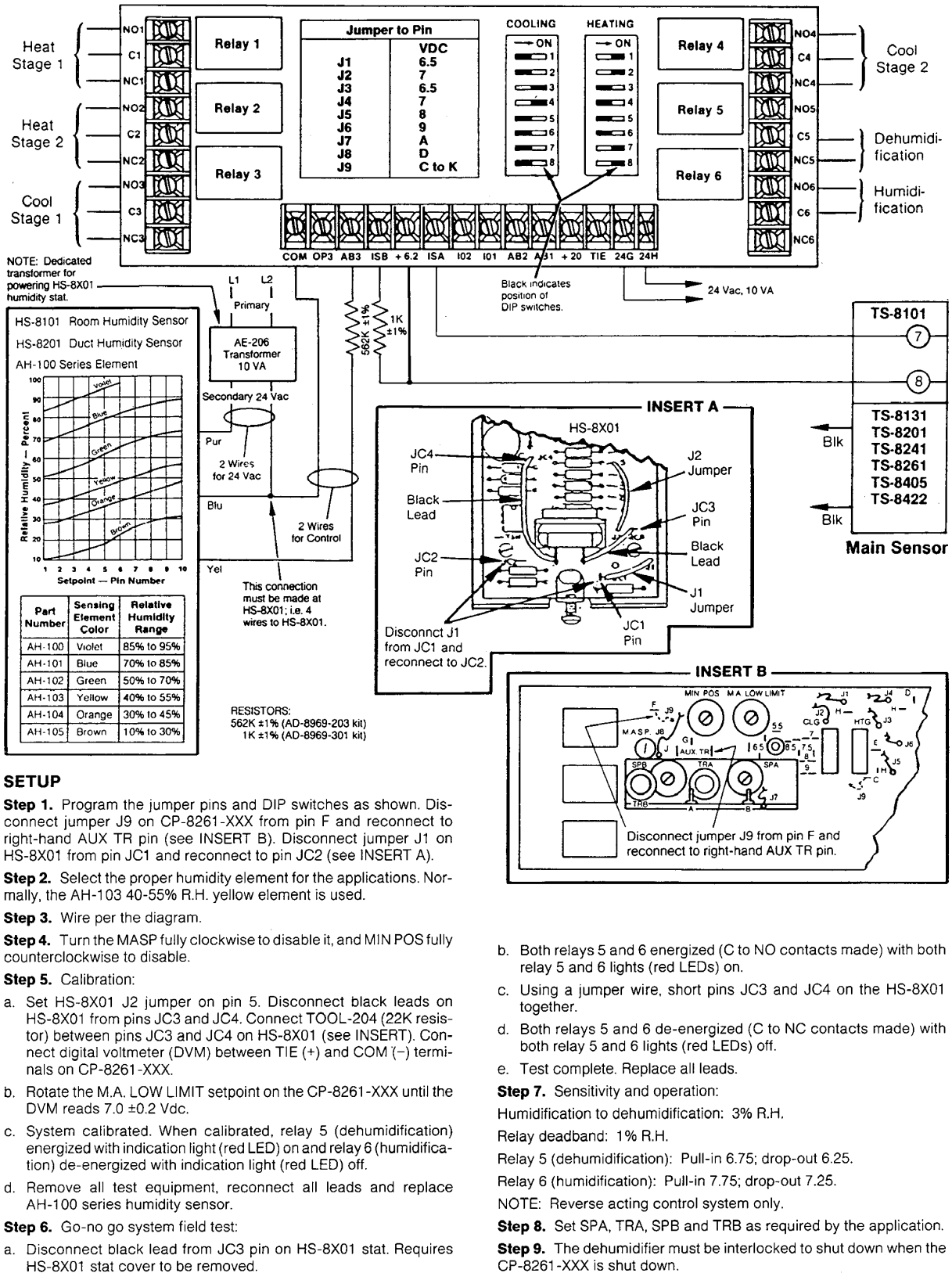
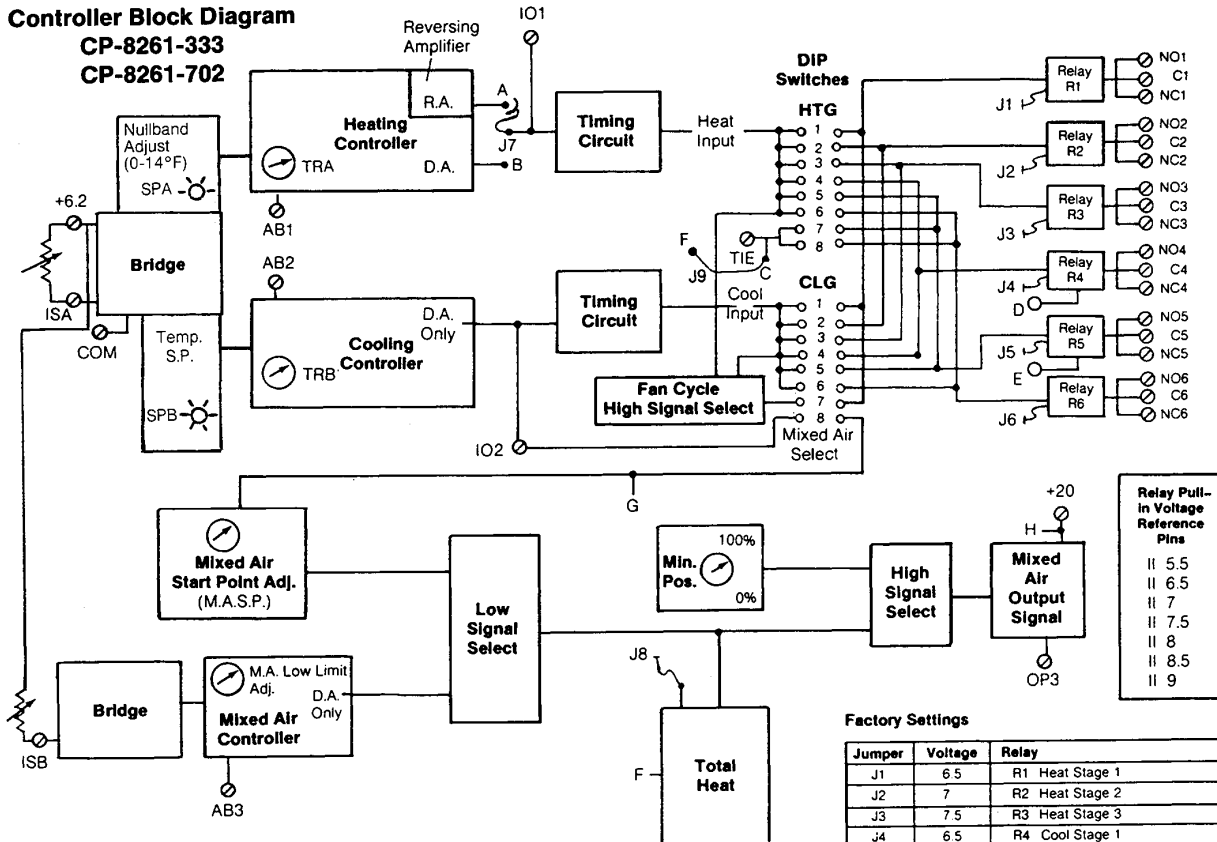

Figure-9

**Controller Block Diagram**  
**CP-8261-333**  
**CP-8261-702**



**Relay Pull-in Voltage Reference Pins**

5.5
6.5
7
7.5
8
8.5
9

**Factory Settings**

Jumper	Voltage	Relay
J1	6.5	R1 Heat Stage 1
J2	7	R2 Heat Stage 2
J3	7.5	R3 Heat Stage 3
J4	6.5	R4 Cool Stage 1
J5	7	R5 Cool Stage 2
J6	7.5	R6 Cool Stage 3
J7	A	Heating signal reverse-acting
J8	D	Mixed air override outside air to minimum ventilation on Stage 1 of cooling (Relay 4)

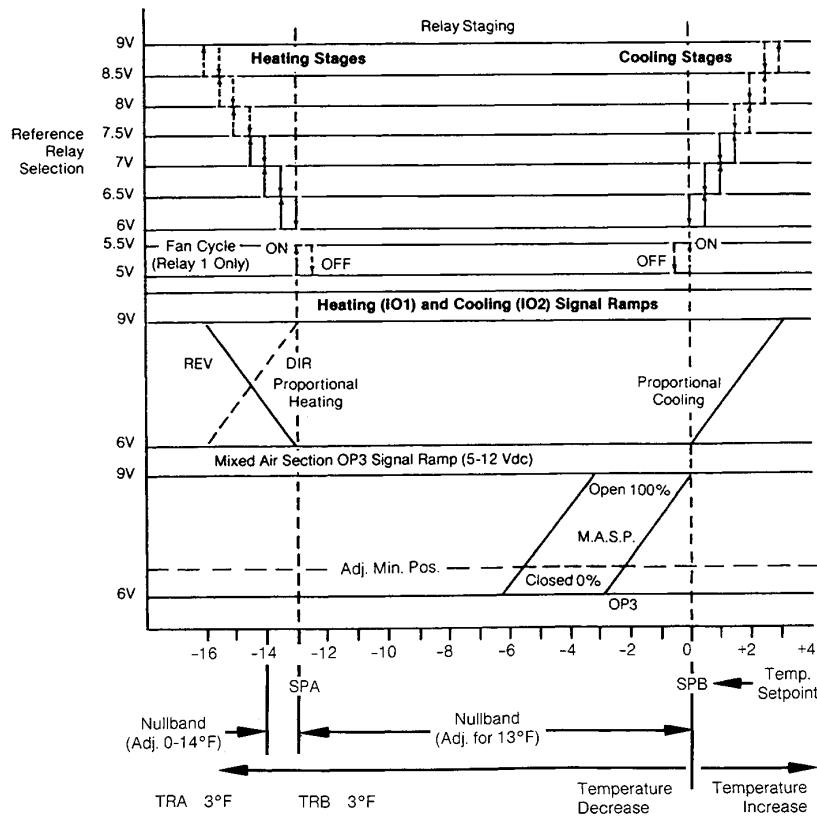

Figure-10 CP-8261-333 and CP-8261-702 Programmable Controller Sequence of Operation.

Jumper	Function		Pin	Function
J1	Relay 1 Operate Reference	T O	5.5 Vdc	Operate Reference for R1-R6 (Selection of J1-J6) Selects Relay Pull-in Voltage Measured at IO1 (Heat) and IO2 (Cool)
J2	Relay 2 Operate Reference		6.5 Vdc	
J3	Relay 3 Operate Reference		7 Vdc	
J4	Relay 4 Operate Reference		7.5 Vdc	
J5	Relay 5 Operate Reference		8 Vdc	
J6	Relay 6 Operate Reference		8.5 Vdc	
J7	HTG Output Select	T O	A	HTG (R.A.) at IO1
J8	Mixed Air Override		B	HTG (D.A.) at IO1
			D	Stage 4 (Cooling 1)
			E	Stage 5 (Cooling 2)
J9		H	Enthalpy/Temperature	
Pin C	TIE Terminal (HTG Switch Position 7 and 8 Off)	F to C	Enthalpy/Temp.	
		Pin F	Enthalpy/Temperature Override (J8 to Pin H)	

**Note:** Jumpers J1-J6 must **always** be placed on pins 6.5 through 9 Vdc (even when not used).  
Pin "C" is jumpered to pin "F" at factory.

**Programming Instructions — HTG/CLG DIP Switches**

HTG DIP Switch		CLG DIP Switch	
Position	Function	Position	Function
1 On	Relay 1 to HTG	1 On	Relay 1 to CLG
2 On	Relay 2 to HTG	2 On	Relay 2 to CLG
3 On	Relay 3 to HTG	3 On	Relay 3 to CLG
4 On	Relay 4 to HTG	4 On	Relay 4 to CLG
5 On	Relay 5 to HTG	5 On	Relay 5 to CLG
6 On	Relay 6 to HTG	6 On	Relay 6 to CLG
7 On	Relay 5 to TIE	7 On	Relay 1 to Fan
8 On	Relay 6 to TIE	8 On	Mixed Air to CLG Ramp

Factory Setting	
Heating Switch	Cooling Switch
1 On	1 Off
2 On	2 Off
3 On	3 Off
4 Off	4 On
5 Off	5 On
6 Off	6 On
7 Off	7 Off
8 Off	8 On

**Note:** Refer to Figures 10 and 13 for further detail. DO NOT place both HTG and CLG DIP switches in the ON position.

Figure-11

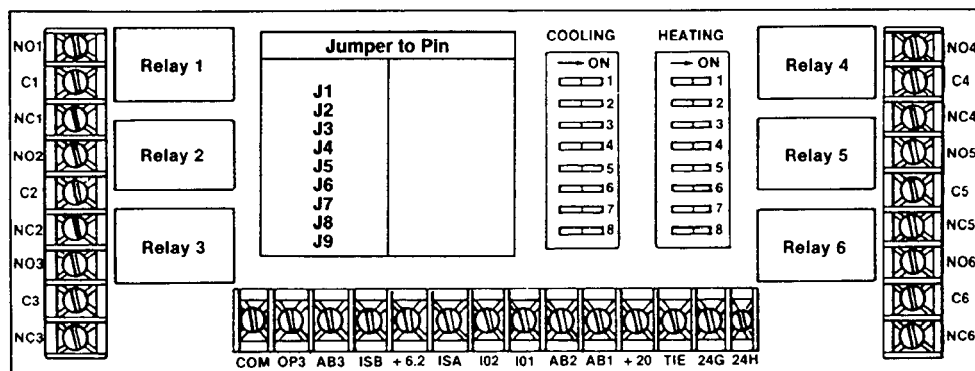

Figure-12

**Note:** Programming aid for selection of jumper/pin locations and DIP switch settings for application programs not shown in these general instructions. Mark the jumper/pin locations and DIP switch settings in the boxes above and inside the CP-8261 cover.

## THEORY OF OPERATION

The CP-8261-XXX programmable controller can be operationally described by dividing the controller into basic functional blocks. Refer to the controller block diagram (Figure 10).

**Zone Thermostats (TS-8000 Series)** The zone thermostat employs a 1000 Ohm 70°F (21°C) resistance type (Balco wire) temperature sensor. Any nonadjustable TS-8000 Series sensor can be used. This sensor increases in resistance with an increase in temperature (2.2 Ohms per °F or 3.96 Ohms per °C). This change is detected by the heating controller and cooling controller in the CP-8261-XXX.

**Heating Controller Section** The heating controller input accepts the zone thermostat resistance signal. The input converts this resistance signal change into a DC millivolt signal change. The DC millivolt signal is then amplified, producing a 2 to 15 Vdc output at terminals IO1 and COM. Selection for direct acting or reverse acting operation is made by positioning jumper J7 to pin A (reverse acting) or B (direct acting). The heating controller output signal is used internally to operate the heating relays or to position an external proportional heating controlled device. Adjustments are available for setpoint 45 to 75°F (7.22 to 23.9°C) and system throttling range 2 to 10°F (1.1 to 5.5°C).

**Cooling Controller System** The cooling controller input also accepts the zone thermostat resistance signal. The input converts this resistance signal change into a DC millivolt signal change. This DC millivolt signal is then amplified, producing a 2 to 15 Vdc output at terminals IO2 and COM. This output is used to operate the cooling relays as well as sequence the mixed air dampers if the cooling DIP switch position 8 is “on”. This output is also available to operate external proportional cooling controlled devices. Adjustments are available for setpoint 70 to 100°F (21 to 37.8°C) and system throttling range 2 to 10°F (1.1 to 5.5°C).

**Mixed Air Thermostat (TS-8000 Series)** The mixed air thermostat functions identically to the zone thermostat described above. The resistance change of the mixed air thermostat is detected by the mixed air controller section of the programmable controller.

### Mixed Air Controller Section

The output at OP3 is factory set to follow the zone cooling controller ramp (by having cooling DIP switch 8 “on”) to provide a 6 to 9 Vdc signal to the mixed air damper actuator as the zone cooling controller output changes from 3 to 6 Vdc.

**Table-3 Mixed Air Controller Auxiliary Throttling Range.**

For Total T.R. °F of:	Add between Aux. T.R.* Pins a Resistor of Value:
11	10 MEG
12	5.1 MEG
13	3.3 MEG
14	2.4 MEG
15	2 MEG
16	1.6 MEG
17	1.5 MEG
18	1.2 MEG
19	1.1 MEG
20	1 MEG

\*no additional pin or jumper setting required.

The mixed air controller accepts the mixed air sensor resistance signal and will override the zone cooling ramp to provide a proportional mixed air low limit.

The mixed air controller has a fixed throttling range of 10°F (5.5°C). Auxiliary pins are provided for other throttling range selections. The mixed air controller setpoint 41 to 95°F (5 to 35°C) establishes a minimum mixed air temperature control point. When the mixed air low limit is reached, the mixed air actuator is proportionally controlled in order to maintain this low limit temperature.

As an option, position 8 on the cooling DIP switch can be placed in the “off” position. This will provide a true mixed air controller and the mixed air will be maintained at the temperature set on the mixed air low limit setpoint. Turn the MASP full clockwise to disable it.

The operating position, with respect to the cooling control outputs, is adjustable by setting the mixed air start point potentiometer.

**Mixed Air Override** An option that provides a method of limiting the volume of outside air taken in when the outside air is unacceptable for free cooling. The input signal is derived from either:

- Outside enthalpy of temperature override thermostats: When pin F is jumpered to pin C, the override condition is created by an open circuit between COM and TIE; override is prevented by a closed circuit between COM and TIE, or
- Signal from stage 1 cooling (J8 jumper connected to pin D) and no connections to TIE, or
- Signal from stage 2 cooling (J8 jumper connected to pin E) and no connections to TIE.

**Minimum Position Section** The minimum position section establishes the minimum DC voltage level to which the output of the mixed air controller is allowed to fall. This DC voltage output between OP3 and COM provides the operating signal for the mixed air actuators.

**Heating/Cooling Sections** The six relays incorporated in the CP-8261-XXX programmable controller can be programmed to operate in either the heating or cooling mode. These relays are programmed by positioning the heating and cooling DIP switches in the “on” position. **Note:** Heating and cooling DIP switches cannot both be in the “on” position. The operating reference for the pull-in voltage of the relays can be

programmed by placing the respective J1 through J6 jumper on the proper operate reference pin. As the voltage from the heating or cooling controller increases through the respective heating or cooling selector DIP switch, the relays will operate when the voltage matches the operate reference selected. There is an interstage time delay on unit start-up.

As an option, relay 1 can be programmed to operate from both the heating and cooling controller for fan operation in the unoccupied mode.

LEDs (light emitting diodes) are provided for each relay stage to indicate the operating status. These LEDs will be "on" when the relay is energized.

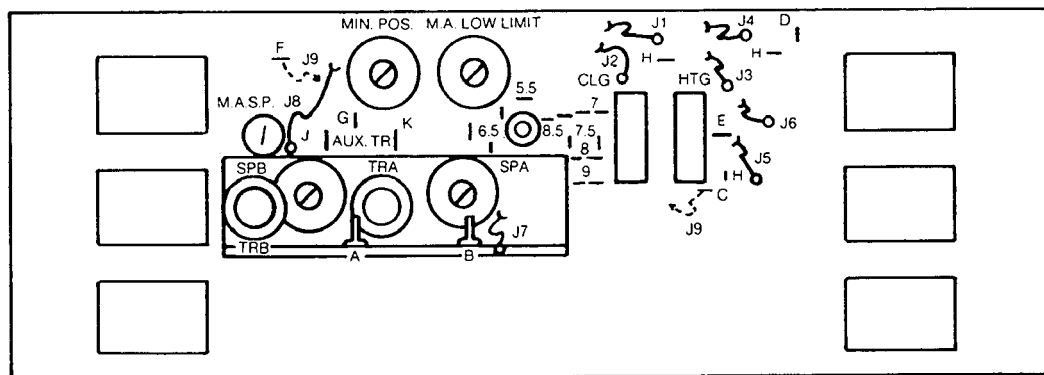
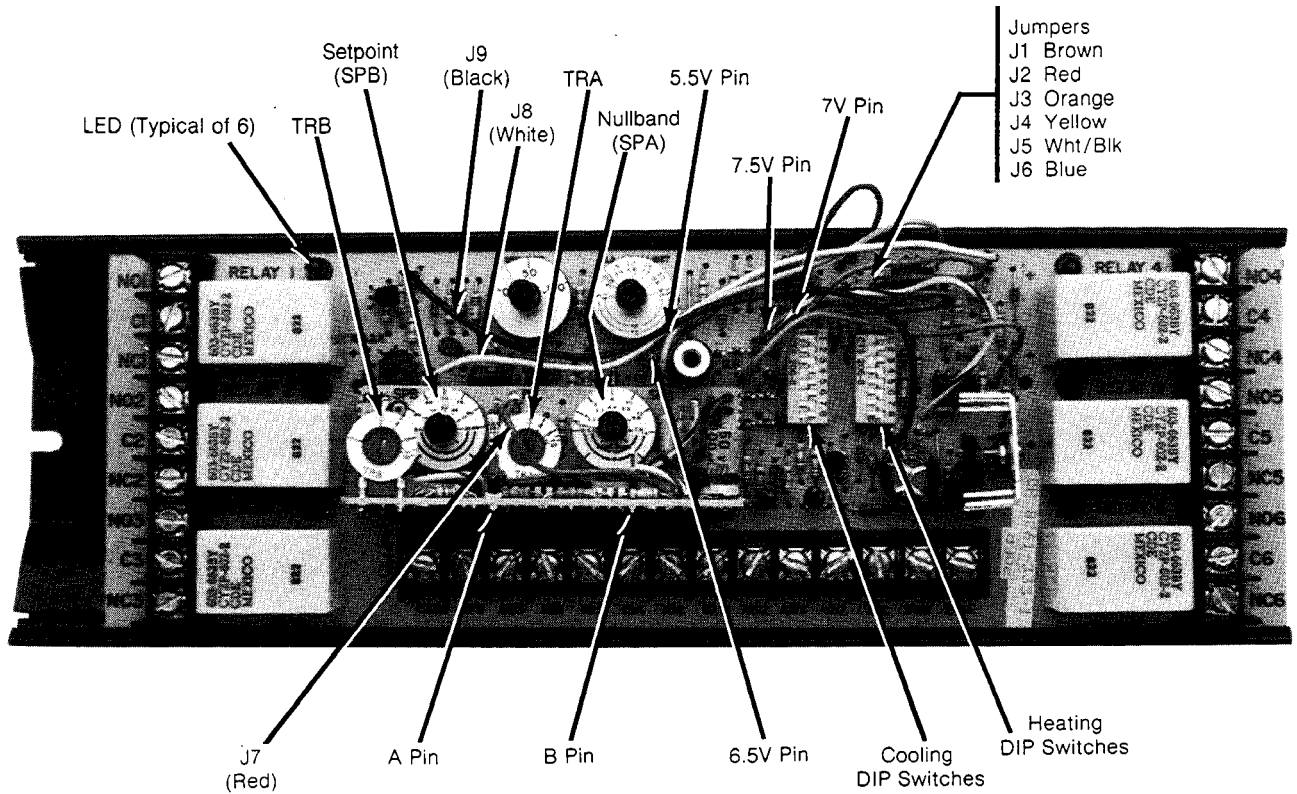

Figure-13 Pin and Jumper Location.

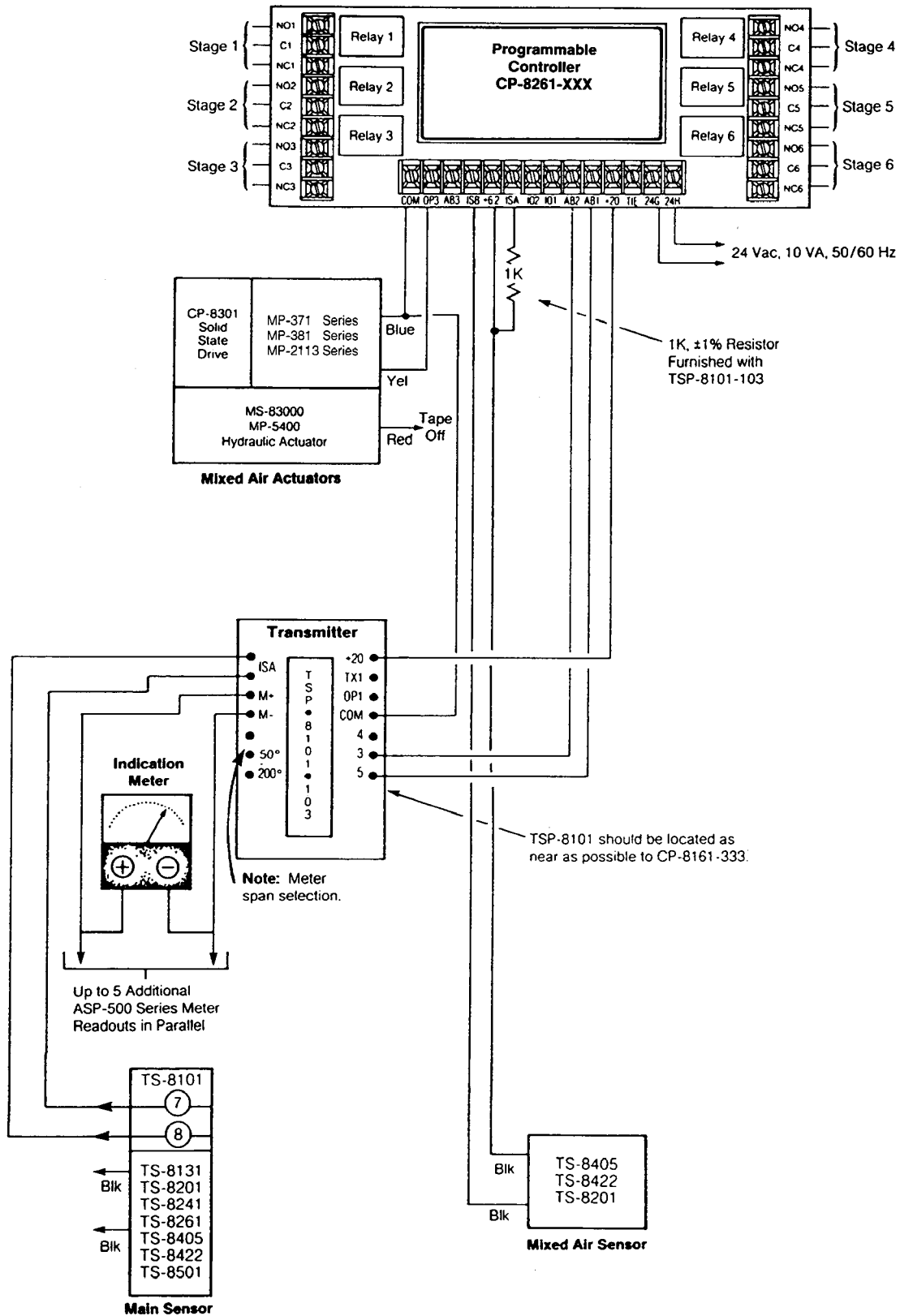

Figure-14 TSP-8101-103 Temperature Transmitter for Temperature Control Plus Temperature Indication Used with CP-8261-XXX Programmable Controller.

## MAINTENANCE

Regular maintenance of the total system is recommended to assure sustained optimum performance.

## FIELD REPAIR

Replace the plug-in circuit board containing the heating and cooling controllers (BDZD-1079) with their respective setpoint and throttling range adjusters (See Figure 13).

1. Remove 24 Vac power to CP-8261.
2. Pull circuit board straight out of the CP-8261.
3. Replace circuit board with functioning unit (BDZD-1079).
4. Restore 24 Vac power to CP-8261.
5. Verify the calibration using the calibration procedure shown on page 8.

---

**Caution:** Plug-in board (BDZD-1079) cannot be used in TP-8124/TP-8125 dual room controllers.

---

---

Copyright 2008, TAC  
All brand names, trademarks and registered  
trademarks are the property of their respective  
owners. Information contained within this  
document is subject to change without notice.

F-23832-2

**TAC**  
1354 Clifford Avenue  
P.O. Box 2940  
Loves Park, IL 61132-2940  
[www.tac.com](http://www.tac.com)

**t.a.c.**   
by **Schneider Electric**