

**Four-Stage Sequencer  
General Instructions**

**APPLICATION**

Electronic four-step sequence controller operates up to four external AC power handling relays or loads in heating, ventilating and air conditioning systems. A second unit can be sequenced to provide up to eight steps.

**SPECIFICATIONS**

**Construction:** Self-contained package with an amplifier.

**Sensors:**

**Balco**, 1000 ohm, requires remote setpoint adjustor (except TS-8111) AT-8100 series (order separately).

**Slidewire**, 135 ohm.

**Input Signals:** 6 to 9 Vdc or 11 to 14 Vdc from a controller.

**Power Demand Override:** Contact closure or proportional 2 to 15 Vdc control signal.

**Throttling Range:** 3 or 6°F (2 or 3°C), 9°F (5°C) can be obtained by the use of AD-8969-901 (order separately). Additional ranges obtainable through selection of resistors (not included).

**Staged Sequencing:** 35 second time delay between stages and return to cold start on power interruption. For electrical ratings see Table 1.

**Control Output Voltage:** 2 to 15 Vdc is available for sequencing up to two TAC System 8000 controlled devices.

**Action:** Factory set for R.A. (reverse acting), but can be made D.A. (direct acting).

**Power Requirements:** 24 Vac 50/60 Hz @ 13 VA plus VA of each stage, maximum 100 VA.

**Power Supplies Available:**

**6.2 ±.4 Vdc**, 7 mA.

**20 -1.5, +1 Vdc**, 50 mA.

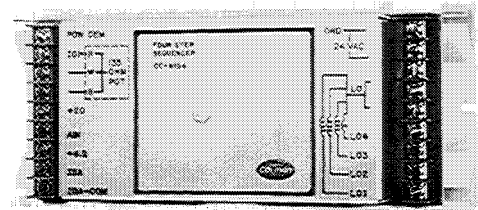

**Environment:**

**Ambient Temperature Limits,**

**Shipping and Storage** -40 to 140°F (-40 to 60°F).

**Operating** 40 to 125°F (4 to 52°C).

**Humidity**, 5 to 95% RH, non-condensing.

**Locations**, NEMA Type 1 indoor only.

**Connections:** Coded screw terminals for 16 to 20 gauge wire.

**Cover:** Aluminum.

**Mounting:** In any position. Printed circuit board is mounted to a section of track for panel installation.

**Dimensions:** 4" high x 9-1/2" wide x 2-1/2" deep (102 mm x 241 mm x 63 mm).

**ACCESSORIES**

AD-8969-201	Offset resistor kit; 5, 10, 15 and 20°F
AD-8969-301	1K ±1%, WW resistor kit
AD-8969-901	Extended throttling range jumper
AT-8100 Series	Remote setpoint adjustors
TS-8000 Series	Sensors
TOOL-201	Calibration kit for TAC System 8000

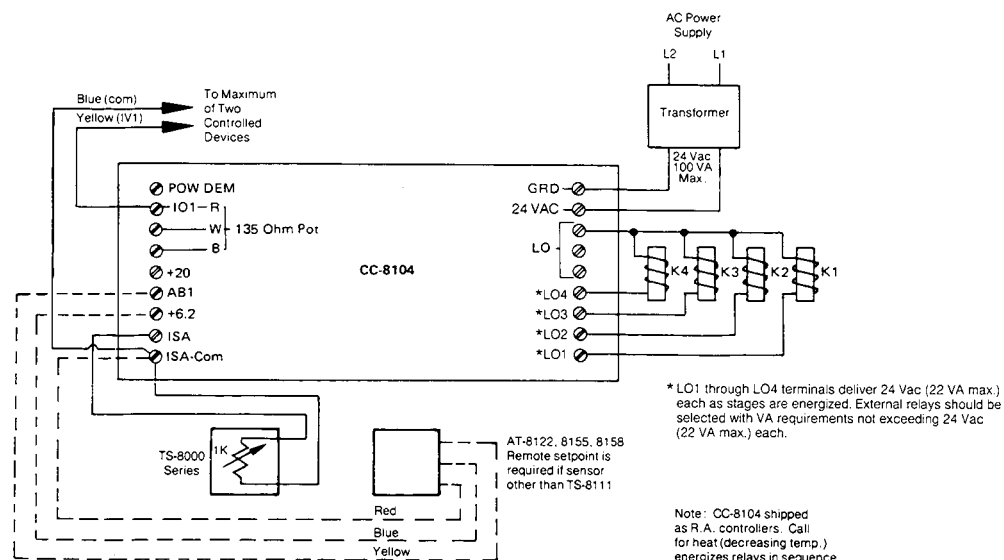

Figure-1 Typical Wiring Diagram for CC-8104.

**Table-1 Maximum Electric Ratings per Output Stage 24 Vac\*.**

Amps	VA Pilot Duty
0.9 (continuous)	22 (sealed)
9 (inrush)	220 (inrush)

\* Minimum Load Amps: 0.1

## THEORY OF OPERATION

A TS-8000 Series sensor, 135 ohm slidewire transducer or a 6 to 9 Vdc signal can be used for detecting changes in the controlled media. Changes (voltage) produced by the various input sensors are amplified by an integrated circuit operational amplifier. The output of the operational amplifier controls a timing circuit. The output of the digital timing circuit controls, in sequence, four electronic output stages which turn on or off power handling relays or loads. See Figure 2.

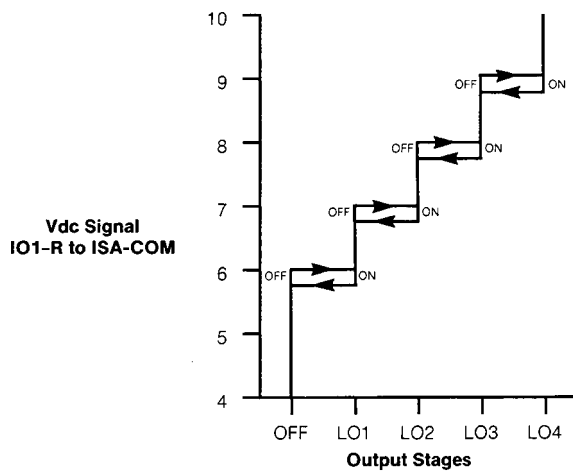

Figure-2 CC-8104 Four-Stage Sequencer Output

## PRE-INSTALLATION

### Inspection

Visually inspect the carton for damage. If damaged, notify the appropriate carrier immediately. If undamaged, open the carton and visually inspect the device for obvious defects. Return damaged or defective products. Check the part number on the unit to be sure the correct device is being installed.

### Required Installation Items

- Wiring diagrams
- Tools (not provided):  
DVM (digital volt-ohm meter)  
Appropriate screwdriver for cover mounting screw, terminal connections and track mounting screws
- Appropriate accessories
- Two (2) #8 mounting screws (not provided)

## INSTALLATION

### Caution:

- Installer must be a qualified, experienced technician.
- Disconnect power supply before installation to prevent electrical shock and equipment damage.
- Make all connections in accordance with wiring diagram, and in accordance with national and local codes. *Use copper conductors only.*
- Do not exceed ratings of the device.
- Avoid locations where excessive moisture, corrosive fumes or vibration are present.

Dimensions in inches ( ) mm

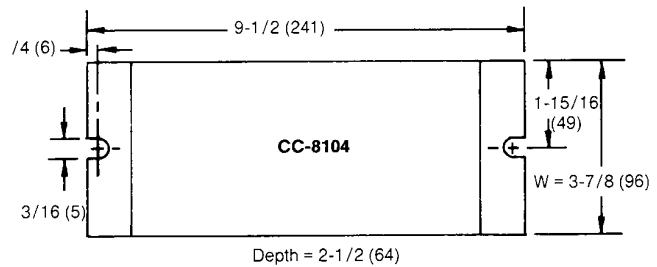

Figure-3 Mounting Dimensions

### Wiring

#### Sensors

Two (2) #18 conductor twisted wires (six turns per foot), Class II, low voltage are suitable for up to 200 ft. (61 m) without calibrating controller. On runs over 200 ft. (61 m), 1000 ft. (305 m) maximum, calibration of the controller is necessary or use larger diameter wire.

**Caution:** Never run line voltage in the same conduit with unshielded sensing element leads.

Use #18 two-conductor shielded cable when it is necessary to install the leads in the same conduit with power wiring, or when high RFI/EMI generating devices are near. Connect the shield at the controller only to the ISA-COM (-) terminal.

#### Controller to Controlled Device(s)

Two (2) #18 conductor twisted wires (six turns per foot), Class II, low voltage are suitable for up to 1000 ft. (305 m); use larger diameter for longer runs.

Use #18 two-conductor shielded cable when it is necessary to install the leads in the same conduit with power wiring, or when high RFI/EMI generating devices are near. Connect the shield at the controller only to the ISA-COM (-) terminal.

#### Power Wiring

Use 16 gauge wire on runs up to 17 ft. (5.2 m) and 12 gauge wire on runs up to 40 ft. (12.2 m).

#### Loads (Relays or Contactors)

Use 16 gauge wire on runs up to 25 ft. (7.6 m) and 12 gauge wire on runs up to 55 ft. (16.8 m).

**Table-2 GENERAL WIRING INFORMATION.**

Wire Gauge	Length of Run in Feet		
	TS-8000 Series to Sensor CC-8104	TS-8601 to CC-8104	CC-8104 to Controlled Device
22	—	—	—
18	1000	1000	1000
16	2250	—	2250
14	4000	—	4000

**TYPICAL WIRING**

**For Direct Action (D.A.)\***

\*Increase in sensed temperature causes relays to energize.

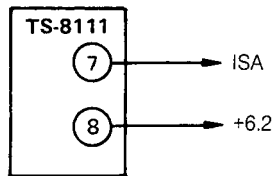

**Note:** See Figure 11.

1. Remove R1 resistor and printed circuit board.
2. Add 1K ±1%, W.W. resistor (AD-8969-301 kit) between CC-8104 terminals ISA and ISA-COM.

**For Reverse Action (R.A.)\***

\*Increase in sensed temperature causes relays to de-energize.

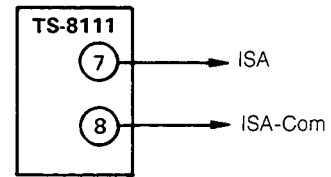
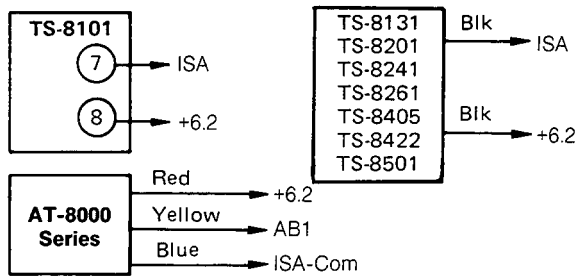

Figure-4 Adjustable Room Sensor.

**For Direct Action (D.A.)\***

\*Increase in sensed temperature causes relays to energize.



**Remote Setpoint Adjuster**

**Note:** See Figure 11.

1. Remove R1 resistor and printed circuit board.
2. Add 1K ±1%, W.W. resistor (AD-8969-301 kit) between CC-8104 terminals ISA and ISA-COM.

**For Reverse Action (R.A.)\***

\*Increase in sensed temperature causes relays to de-energize.

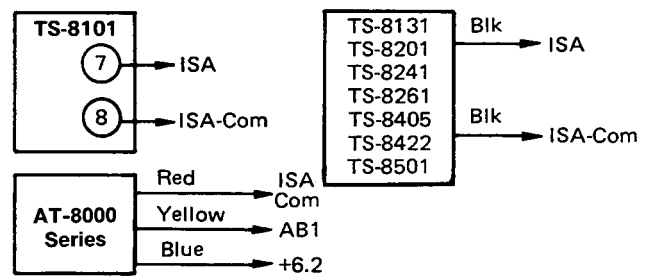

**Remote Setpoint Adjuster**

Figure-5 Non-Adjustable Sensors with Remote Setpoints.

**For Direct Action (D.A.)\***

\*135 ohm transducer wiper (R) travels to W end, relays energize.

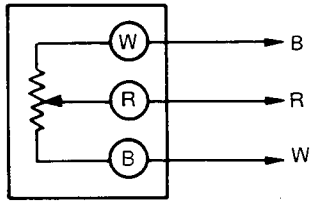

**Note:** Requires removal of jumper J1 from CC-8104. See Figure 11 for details.

**For Reverse Action (R.A.)\***

\*135 ohm transducer wiper (R) travels to W end, relays de-energize.

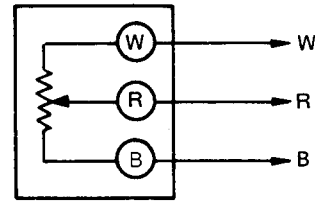

**Note:** Requires removal of jumper J1 from CC-8104. See Figure 11 for details.

Figure-6 135 Ohm Slidewire for Single CC-8104 Only.

**For Direct Action (D.A.)\***

\*Increase in sensed temperature causes relays to energize.

**2-Input Controller CP-8102**

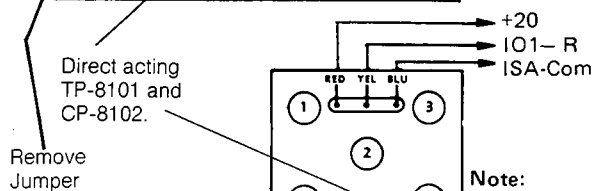
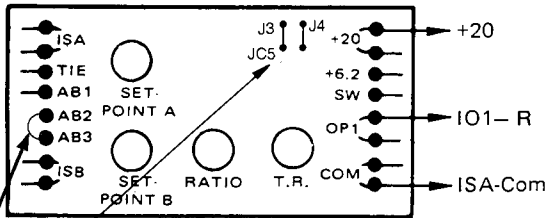

**Note:** Requires removal of J1 jumper in CC-8104. See Figure 11 for details.

**TP-8101 Room Controller**

**Note:** 4 to 5 – D.A.

**For Reverse Action (R.A.)\***

\*Increase in sensed temperature causes relays to de-energize.

**2-Input Controller CP-8102**

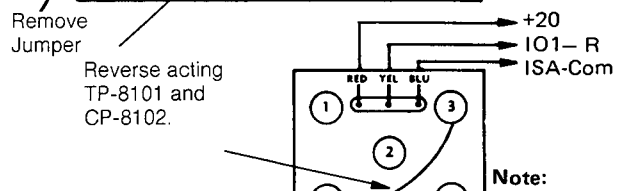
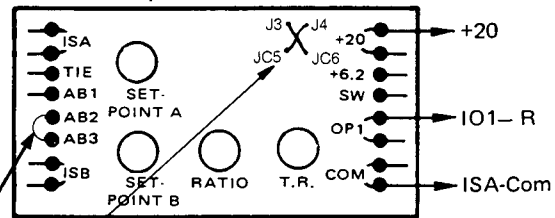

**Note:** Requires removal of J1 jumper in CC-8104. See Figure 11 for details.

**TP-8101 Room Controller**

**Note:** 3 to 4 – R.A.

Figure-7 TP-8101 and CP-8102 Controllers.

### For Direct Action (D.A.)\*

\*Increase in sensed temperature causes relays to energize.

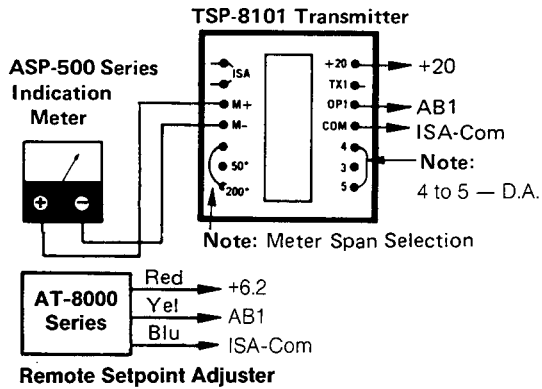

**Note:** See Figure 11.

1. Add 1K  $\pm$ 1%, W.W. resistor (AD-8969-301 kit) between CC-8104 terminals ISA and ISA-COM.
2. Do not remove R1 resistor from CC-8104.

### For Reverse Action (R.A.)\*

\*Increase in sensed temperature causes relays to de-energize.

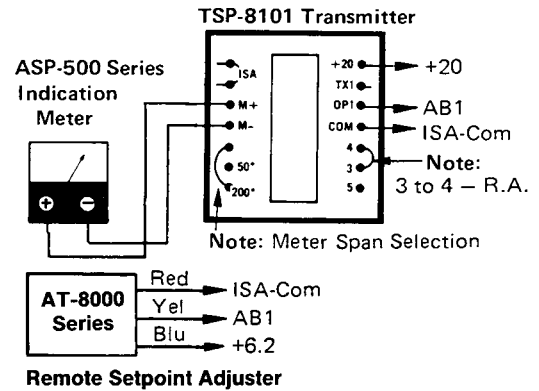

**Note:** See Figure 11.

1. Add 1K  $\pm$ 1%, W.W. resistor (AD-8969-301 kit) between CC-8104 terminals ISA and ISA-COM.
2. Do not remove R1 resistor from CC-8104.

Figure-8 Control and Identification.

### For Direct Acting Control (D.A.) with Reverse Reset (R.R.)

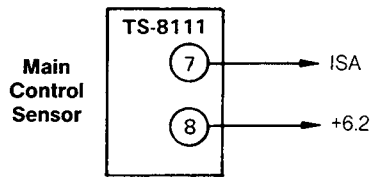

**Note:** See Figure 11.

1. Remove R1 resistor and printed circuit board.
2. Add 1K  $\pm$ 1%, W.W. resistor (AD-8969-301 kit) between CC-8104 terminals ISA and ISA-COM.

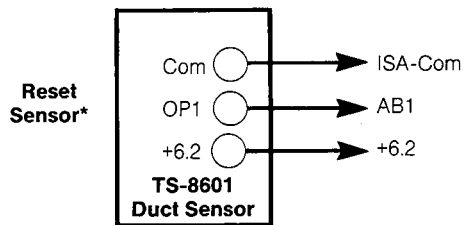

**Note:** Use with adjustable room sensors, non-adjustable sensors, TP-8101 and CP-8102 controllers, and control and indication. (See Figures 4 and 5.)

\*For direct acting control (D.A.) with direct reset (D.R.), connect +6.2 terminal of TS-8601 to ISA-COM on CC-8104 and COM terminal of TS-8601 to +6.2 terminal on CC-8104.

### For Reverse Acting Control (R.A.) with Reverse Reset (R.R.)

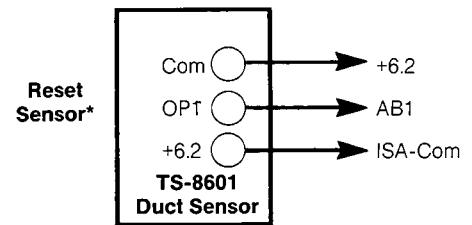
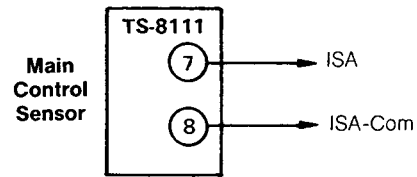

**Note:** Use with adjustable room sensors, non-adjustable sensors, TP-8101 and CP-8102 controllers, and control and indication. (See Figures 4 and 5.)

\*For reverse acting control (R.A.) with direct reset (D.R.), connect +6.2 terminal of TS-8601 to +6.2 terminal of CC-8104 and COM terminal of TS-8601 to ISA-COM terminal on CC-8104.

Figure-9 Ratio Discharge Control.

**SYSTEM 8000  
Controlled Devices**

CC-8100 Series  
CP-8301 Series  
MP-5200 Series\*  
MS-83000 Series  
MS-1233 Series  
SP-40000 Series  
CP-8511 Series  
CP-8513 Series

\*Requires AD-8969-611 kit between red and blue leads.

**Note:** Max. of two units.

**RELAY SPECIFICATIONS**

1. Voltage: 24 VAC
2. Current (amps): Continuous
  - a. 4-stages: 0.9 max.
  - b. 8-stages: 0.4 max.\*

\*Restricted for 100 VA transformers as required by UL for Class 2 wiring.

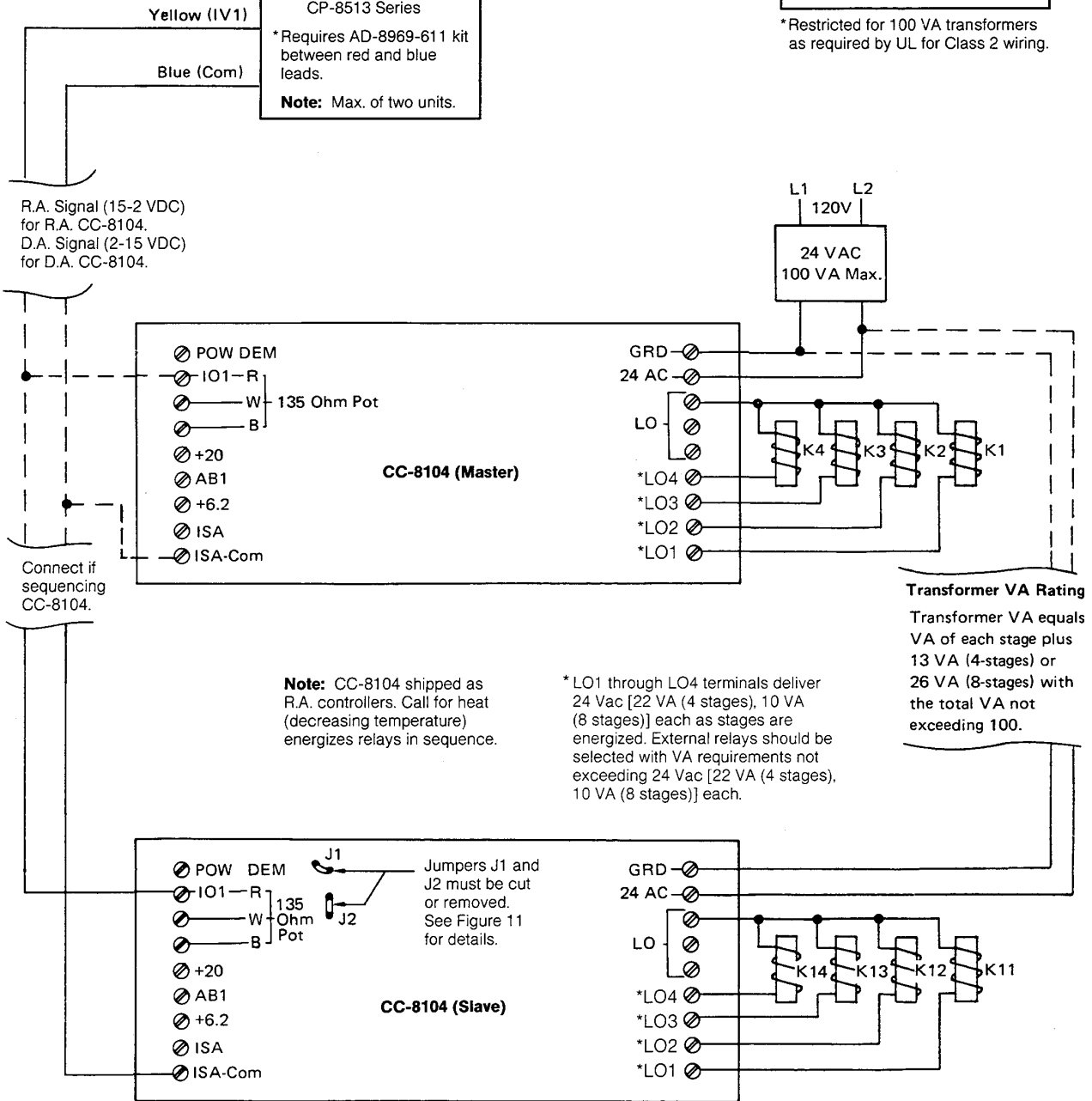

Figure-10 CC-8104 Master and Slave System.

## FIELD ADJUSTMENTS

### Action

The CC-8104 is factory set for Reverse Action (a decrease in the sensed temperature causes the relays to energize). For Direct Action (an increase in the sensed temperature causes the relays to energize), remove the 1K resistor (marked R1) from the printed circuit board and add 1K  $\pm$ 1% W.W. resistor (AD-8969-301 kit) between terminals ISA and ISA-COM. See Figure 11.

### Sequencing or Parallel Operation

See Figures 10 and 11.

Removal of J1 jumper from printed circuit board will disable the controller circuit of slave CC-8104. This removal will allow a master CC-8104 to parallel a slave CC-8104.

Removal of jumper J2 allows a master CC-8104 to sequence a slave CC-8104 from 11 to 14 Vdc. A master CC-8104 can operate from 11 to 14 Vdc if J2 jumper is removed.

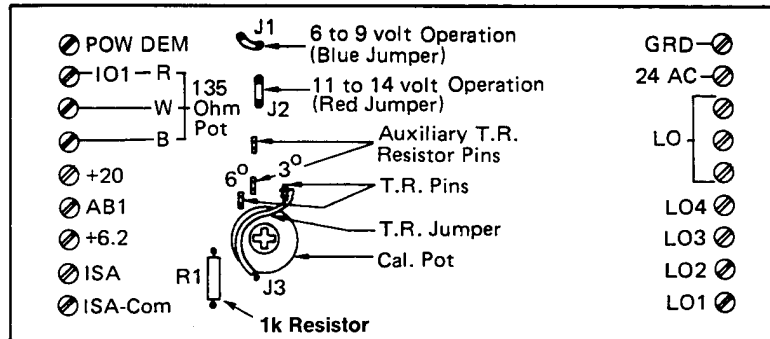

Figure-11 CC-8104 Field Adjustments.

### Throttling Range

See Figure 11 and Table 3.

The throttling range jumper (J3) is factory set to 3°F (1.7°C). Move jumper J3 to 6°F (3°C) pin for greater throttling range or 9°F (5°C) by using AD-8969-901 jumper (order separately).

Additional throttling ranges are available by resistor selection. (See Table 3.) Select required resistor for specified throttling range. Solder resistor between auxiliary resistor pin terminals on printed circuit board. Connect throttling range jumper J3 to lower auxiliary resistor pin.

**Table-3 AUXILIARY THROTTLING RANGES.**

Throttling Range (°F)	T.R. Resistors*
8	560k
12.5	360k
15	300k
25	180k
30	150k
40	110k
50	91k
60	75k

\*  $\pm$ 5%, 1/2W, Carbon

### CHECKOUT

After the system has been installed, the following checks for proper controller and system operation can be made. (See Figure 11.)

1. Check for 24 Vac by measuring at the GRD and 24 Vac terminals on the controller. If the 24 Vac is not present, then check transformer input voltage source. If the transformer input voltage source is present, then consider the transformer as defective and replace.
2. Check the 20 -1.5 +1.0 Vdc source on the controller by connecting a DVM between the +20 terminal (+) and ISA-COM terminal (-). If the 20 Vdc is not present or is out of tolerance, consider the controller as defective and replace.
3. Check the 6.2  $\pm$  .4 Vdc source on the controller by connecting a DVM between the +6.2 terminal (+) and ISA-COM terminal (-). If the 6.2 Vdc is not present or is out of tolerance, consider the controller as defective and replace.
4. Turn the temperature setpoint 9 to 10°F (5°C) above sensor temperature. All load relays should energize in sequence (if CC-8104 is connected for reverse acting) after appropriate time delays. Connect a DVM between the OP1-R terminal (+) and ISA-COM terminal (-). A reading of 15 Vdc or greater should be obtained. If the above operation is not obtained, check the sensor. The TS-8000 Series sensor should equal approximately 1000 ohms at 70°F (sensor changes 2.2 ohms per °F). If the sensor is good, then consider the controller as defective and replace.
5. Turn the temperature setpoint 9 to 10°F (5°C) below sensor temperature. All load relays should de-energize in sequence after appropriate time delays. Connect a DVM between the IO1 terminal (+) and ISA-COM terminal (-). A reading of 2 Vdc or less should be obtained. If this reading is not obtained, consider the controller as defective and replace.

## CALIBRATION

The CC-8104 is factory calibrated and normally requires no field calibration. If field calibration is required, proceed as follows:

1. Measure the temperature at the thermostat or sensor with a reliable thermometer.
2. Adjust the setpoint to agree with the measured temperature.
3. Connect a DVM to the IO1 terminal (+) and ISA-COM terminal (-) of the controller.
4. The system is in calibration if the VOM reads  $7.5 \pm 1$  Vdc. Also the first two stages should be energized after appropriate time delay. If the  $7.5 \pm 1$  Vdc reading is not obtained then:

### **TS-8111 Adjustable Room Thermostat (See Figure 4.)**

- a. Place thumb of the left hand over setpoint knob so it cannot move.

---

**Caution:** Keep hands as far away from sensor as possible in order to prevent heating of the sensor.

---

- b. Using the right hand, insert a 5/64" Allen wrench through the hole in the side of the thermostat into the setpoint knob.
- c. Rotate the Allen wrench, making sure to hold the setpoint knob firmly in place, until a DVM reading of  $7.5 \pm 1.25$  Vdc is obtained.
- d. The system is now calibrated.

### **Non-Adjustable Sensors with Remote Setpoints, 135 Ohm Slidewire with Single CC-8104 and Ratio Discharge Control (See Figures 5, 6 and 9)**

- a. Remove setpoint knob.
- b. Adjust setpoint potentiometer until a DVM reading of  $7.5 \pm 1$  Vdc is obtained.
- c. Replace setpoint knob agreeing with temperature measured at the sensor.
- d. The system is now calibrated.

### **TP-8101 and CP-8102 Controllers**

Calibrate CP-8102 or TP-8101 according to General Instructions F-18097 or F-14969.

## MAINTENANCE

Regular maintenance of the total system is recommended for sustained optimum performance.

## REPAIR

If the CC-8104 should not operate according to specifications, replace the unit as defective.