

**Contents**

How to Select the Globe Valve Retrofit Solution ..... pg 31  
 Globe Valve Retrofit Actuators ..... pg 32

**Solutions for Specific Manufacturer and Part Number**

Honeywell ..... pg 33  
 Johnson Controls ..... pg 36  
 Robertshaw ..... pg 40  
 Siebe - Invensys - Barber Colman ..... pg 42  
 Siemens - Landis - Powers ..... pg 44  
 Warren Controls ..... pg 47

Custom Globe Valve Solutions ..... pg 49  
 Custom Globe Valve Retrofit Solution Form..... pg 50  
 UGSP Series Globe Valve Retrofit Solution, Identification... pg 52  
 UNV Retrofit Solution ..... pg 62  
 UNV Retrofit Installation Instructions ..... pg 63  
 NV Series Globe Valve Actuators..... pg 66  
 UGLK/UGSP Retrofit Solution..... pg 70  
 Valve Accessories ..... pg 81



**Globe Valves:**  
**UNV Series** Direct Coupled Actuator  
 2-way Valves  
 3-way Valves  
**UGLK Series** Linkage Solution  
 2-way Valves  
 3-way Valves

**Retrofit Solutions for Virtually any Valve**  
**Manufacturers:**  
**Globe:** Siemens, Johnson  
 Honeywell, Invensys  
 and more  
**Control:** On/Off, Floating, 2-10 VDC  
 Multi-Function Technology®  
 Spring Return or  
 Non-Spring Return

L-30043 - 07/09 - SUBJECT TO CHANGE. © BELIMO AIRCONTROLS (USA), INC.

## Self Adapting Stroke

The NV Series actuators, which are used with the UNV retro-fit kits (Figure 1), are stroke adapting actuators. In modulating applications, the actuator will recognize the stroke length requirement and automatically adjust the control signal for maximum resolution.

## Ratings for Steam Application

The UNV-035 is rated for 50 psi inlet steam. All other UNV solutions are rated for 15 psi inlet steam.

All UGLK linkages can be used with Belimo actuators up to a maximum of 50 psi steam

For other applications between 50 psi and 100 psi inlet steam, please call Belimo Customer Service for assistance



Figure 1

## Spring Return Function

When ordering a UNV kit with an NV Series spring return actuator, you must know the required spring return direction. The NVF24-MFT US springs to the UP position and the NVF24-MFT-E US springs to the DOWN position.

If the required spring return direction is not known, a UGLK linkage (Figure 2) and spring return actuator may be selected. The rotary actuators can be turned over on the linkage and produce a spring return function in either direction.

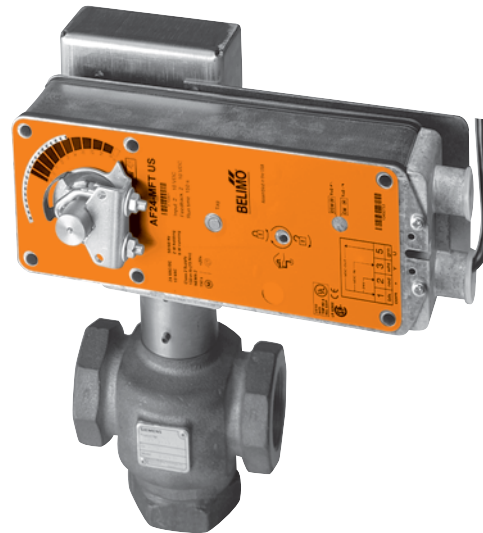
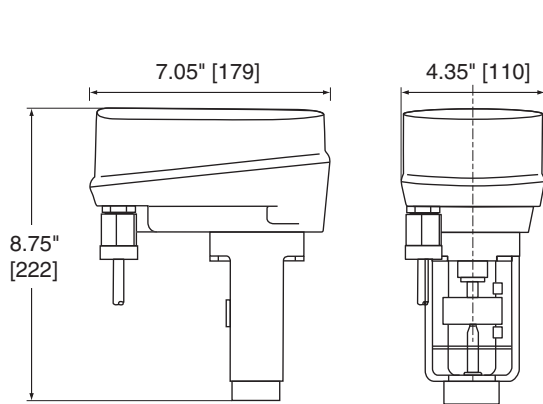

Figure 2

## Maximum Dimensions – UNV with NV Series Actuators



UNV-001 Dimensions in inches (numbers in brackets are metric)

D033

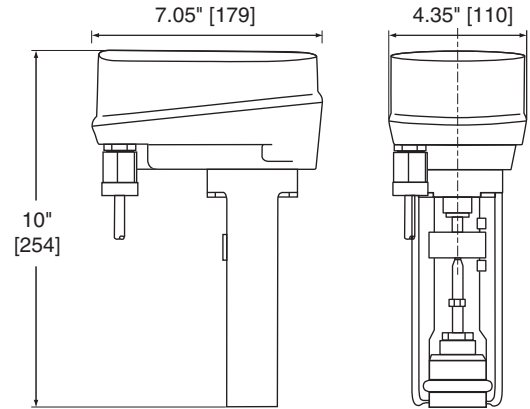

UNV-003-UNV-051 Dimensions in inches (numbers in brackets are metric)

D034

## Maximum Dimensions – UGLK Linkages with Rotary Actuator

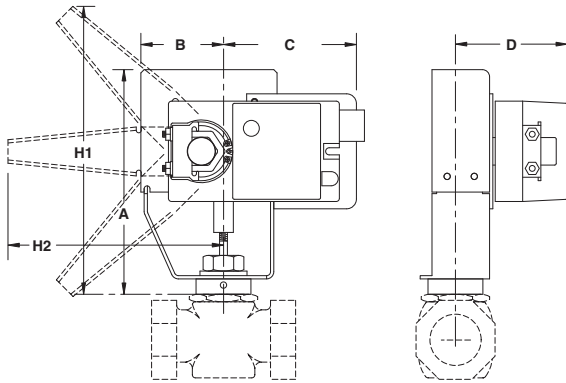

Linkages Taking 1 Actuator

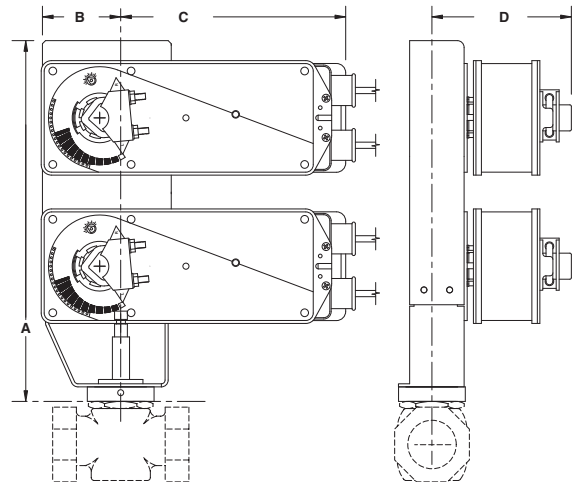

Linkages Taking 2 Actuators

### Maximum Dimensions

#### Linkages Taking 1 Actuator

A	9.5"	D	5"
B	3"	H1	14"
C	9"	H2	9.5"

#### Linkages Taking 2 Actuators

A	19"	D	5"
B	3"		
C	9"		

#### UGLK1150 and UGLK1550

A	6.5"	D	4.0"
B	1.5"	H1	4.0"
C	5.0"	H2	3.5"

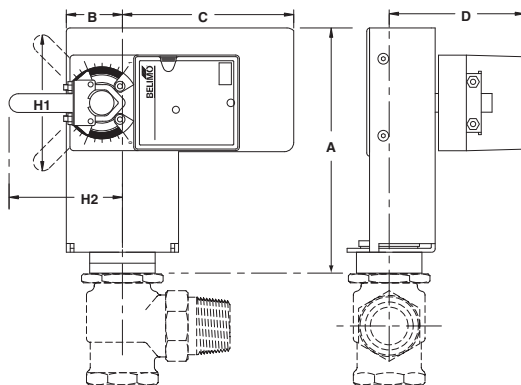

UGLK1150 and UGLK1550

L-30043 - 07/09 - SUBJECT TO CHANGE. © BELIMO AIRCONTROLS (USA), INC.

Linear Actuators						
Series	Model	Spring Return	Control Input	Feedback Position	Power Supply	Standard Running Time
NVF Series	NVF24-MFT US	spring UP	Variable with MFT (VDC, PWM, Floating Pt., On/Off)	variable VDC	24 VAC/DC	150 seconds
	NVF24-MFT-E US	spring DOWN	Variable with MFT (VDC, PWM, Floating Pt., On/Off)	variable VDC	24 VAC/DC	150 seconds
NV Series	NV24-3 US		Floating Pt., On/Off		24 VAC/DC	150 seconds
	NV24-MFT US		Variable with MFT (VDC, PWM, Floating Pt., On/Off)	variable VDC	24 VAC/DC	150 seconds
NVG Series	NVG24-MFT US		Variable with MFT (VDC, PWM, Floating Pt., On/Off)	variable VDC	24 VAC/DC	150 seconds

Rotary Actuators						
Series	Model	Spring Return	Control Input	Feedback Position	Power Supply	Standard Running Time
LF Series*	LF24 US	•	24 VAC/DC		24 VAC/DC	Consult Specifications
	LF24-MFT US	•	Variable with MFT (VDC, PWM, Floating Pt., On/Off)	variable VDC	24 VAC/DC	
NF Series*	NF24 US	•	24 VAC/DC		24 VAC/DC	
	NF24-MFT US	•	Variable with MFT (VDC, PWM, Floating Pt., On/Off)	variable VDC	24 VAC/DC	
AF Series*	AF24 US	•	24 VAC/DC		24 VAC/DC	
	AF24-MFT US	•	Variable with MFT (VDC, PWM, Floating Pt., On/Off)	variable VDC	24 VAC/DC	
LM Series*	LMB24-3X1		Floating Pt., On/Off		24 VAC/DC	
	LMB24-MFTX1		Variable with MFT (VDC, PWM, Floating Pt., On/Off)	variable VDC	24 VAC/DC	
NM Series*	NMB24-3X1		24 VAC/DC		24 VAC/DC	
	NMB24-MFTX1		Variable with MFT (VDC, PWM, Floating Pt., On/Off)	variable VDC	24 VAC/DC	
AM Series*	AMB24-3X1		24 VAC/DC		24 VAC/DC	
	AMB24-MFTX1		Variable with MFT (VDC, PWM, Floating Pt., On/Off)	variable VDC	24 VAC/DC	
GM Series*	GMB24-3X1		24 VAC/DC		24 VAC/DC	
	GMB24-MFTX1		Variable with MFT (VDC, PWM, Floating Pt., On/Off)	variable VDC	24 VAC/DC	

\*Please consult the Product Guide and Price List for a complete selection of Spring Return and Non-Spring Return Actuators of the listed series. Standard run times should be considered in the selection.

Multi-Function Technology								
Programming Codes				Control Input	Running Time	Built-in Feedback		
NV CODES	V-10001	N01	ROTARY ACTUATOR CODES	P-10001	A01	2-10 VDC	150 seconds	2-10 VDC
	V-10002	N02		P-10002	A02	0-10 VDC	150 seconds	0-10 VDC
	V-10028	N1E		P-10028	A28	0-10 VDC	150 seconds	0-10 VDC
	V-10063	N1K		P-10063	A63	0.5-4.5 VDC	150 seconds	0.5-4.5 VDC
	V-10064	N1L		P-10064	A64	5.5-10 VDC	150 seconds	5.5-10 VDC
	V-20002	N1U		P-20002	W02	0.02-5.00 seconds PWM	150 seconds	2-10 VDC
	V-20003	N1V		P-20003	W03	0.10-25.5 seconds PWM	150 seconds	2-10 VDC
	V-30001	N24		P-30001	F01	Floating Pt.	150 seconds	2-10 VDC
V-40002	N29	P-40002	J02	On/Off	150 seconds	2-10 VDC		

Note: V-codes used for NV...Series actuator. All other MFT actuators use P-codes.

**NV, NVG, NVF Series Direct Coupled Solution**

Valve				Linkage Solution	
Valve Body Model	Body Type	Configuration	Size	UNV-001	UNV-035
VB7000 series	NPT	2-way/3-way	½" to 2"	UNV-001	
VB9000 series	NPT	2-way/3-way	½" to 1¼"	UNV-001	
Belimo USA G2 and G3 series	NPT	2-way/3-way	½" to 2"	UNV-001	
VB7000 series	NPT	2-way/3-way	½" to 2"		UNV-035
VB9000 series	NPT	2-way/3-way	½" to 1¼"		UNV-035
Belimo USA G2...S	NPT	2-way	½" to 2"		UNV-035

\* UNV-035 can be used in steam application up to 50 psi inlet.

**CLOSE-OFF PRESSURE (psi)**

Linkage	Valve Size	CLOSE-OFF PRESSURE (psi)		
		Spring Return	Non-Spring Return	
		NVF Series	NV Series	NVG Series
UNV-001 UNV-035	½"	250	250	250
	¾"	250	250	250
	1"	183	229	250
	1¼"	117	147	235
	1½"	82	102	160
	2"	46	57	90

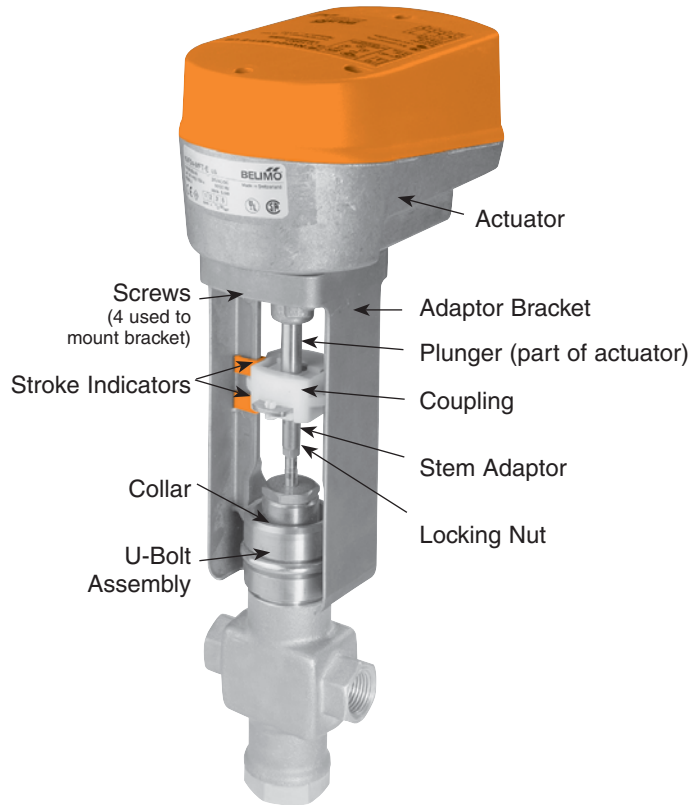

**UNV-Box-Kit**

Multi Box Starter Kit for UNV

Refillable with below items.

**UNV Multi-box Kit Components**

Part No.	Description	Part No.	Description
UNV-BKT-001	SIEBE bracket (UNV-001)	UNV-STEM-006	Stem Adaptor-006
UNV-BKT-002	Universal bracket (UNV-003 through UNV-035)	UNV-STEM-007	Stem Adaptor-007
UNV-COL-004	Collar-004 and set screws	UNV-STEM-035	Stem Adaptor-035
UNV-COL-005	Collar-005	UNV-STEM-040	Stem Adaptor-040
UNV-COL-006	Collar-006 and set screws	UNV-NUT-001	1/4"-28 Locking Nut (UNV-001, 004, 005, 006, 008, 009, 035)
UNV-COL-007	Collar-007	UNV-NUT-007	1/4"-32 Locking Nut (UNV-007)
UNV-COL-008	Collar-008	UNV-BOLT	Kit of U-bolt, Nuts for U-bolt
UNV-COL-009	Collar-009	UNV-SCREW	Kit of Screws
UNV-COL-035	Collar-035	UNV-STROKE IND	Kit of Stroke indicators
UNV-COL-040	Collar-040	UNV-CPL	Coupling
UNV-STEM-001-SET	Stem Adaptor-001,005	UNV-CPL	Coupling-10 pc set
UNV-STEM-003	Stem Adaptor-003	UNV-Override	NV Manual Override
UNV-STEM-004-SET	Stem Adaptor-004,008,009		

**UNV Dimensional Details**

Dimensional Data	UNV-001	UNV-003	UNV-004	UNV-005	UNV006	UNV-007	UNV-008	UNV-009	UNV-035	UNV-040	UNV-051
Length of Stem Adaptor	1 7/16"	2"	2 1/8"	1 7/16"	1 1/8"	2 1/8"	2 1/8"	2 1/8"	3 7/16"	2 1/8"	1-1/4"
Stem Adaptor Diameter	1/4"	5/8"	1/4"	1/4"	1/4"	1/4"	1/4"	1/4"	1/4"	1/4"	3/8"
Stem Adaptor-Threads Per In.	28	N/A	28	28	28	32	28	28	28	28	24
Locking Nut	1/4"-28	N/A	1/4"-28	1/4"-28	1/4"-28	1/4"-32	1/4"-28	1/4"-28	1/4"-28	1/4"-28	3/8"-24
Collar	Molded into Bracket	N/A	YES 1/4"-20 set screws	YES	YES 1/4"-20 set screws	YES	YES	YES	YES-303 SS	YES	YES
U-Bolt	N/A	YES	YES	YES	YES	YES	YES	YES	YES	YES	YES
Adaptor Bracket	UNV-BKT-001	UNV-BKT-002	UNV-BKT-002	UNV-BKT-002	UNV-BKT-002	UNV-BKT-002	UNV-BKT-002	UNV-BKT-002	UNV-BKT-002	UNV-BKT-002	UNV-BKT-002

800-543-9038 USA

866-805-7089 CANADA

203-791-8396 LATIN AMERICA

L30043 - 07/09 - SUBJECT TO CHANGE. © BELIMO AIRCONTROLS (USA), INC.

## Operation/Installation UNV-001 Series

### Installation Instructions for Siebe VB7000 and VB9000 Series Valves

#### Preparing the Valve

1. Remove all existing linkage and push stem to down position.
2. Screw lock nut (L) and stem adaptor (I) onto valve stem.
3. With stem pushed down completely adjust stem adaptor (I) height for corresponding valve. Tighten lock nut (L). (See Figure 1).

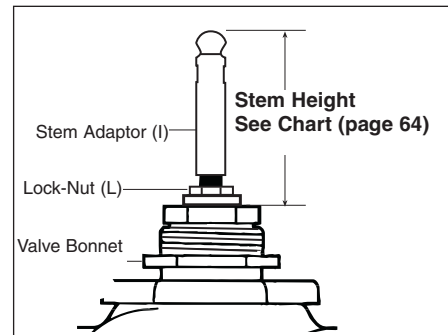

Fig. 1

#### Preparing the Actuator and Mounting the Valve

1. Slide the black coupling lock (C) up into the unlocked position. (See Figure 3).
2. Attach it to the end of the actuator plunger (K). This is done by pushing the bottom of the coupling apart with your thumbs while pressing it onto the actuator plunger. (See Figure 5).
3. Attach bracket (E) onto bottom of NV actuator (A) with 4 provided screws (B).
4. Attach stroke indicators (G) above and below the valve coupling.
5. Screw NV actuator (A) onto valve, and tighten valve bonnet nut (J).
6. Lower plunger (K) using manual override until stem adaptor (I) meets valve coupling. When connected, the valve stem adaptor will be captured by the valve coupling.
7. Slide the coupling lock (C) down in to its locked position.
8. Move sliding stroke indicators (G) to sit above and below lip on valve coupling (H). Stroke indicators are automatically repositioned to the maximum stroke when power is applied to actuator.
9. Set actuator switches S3.1, S3.2 to desired settings (See attached data).

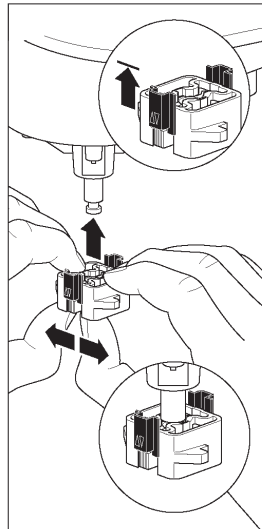

Fig. 5

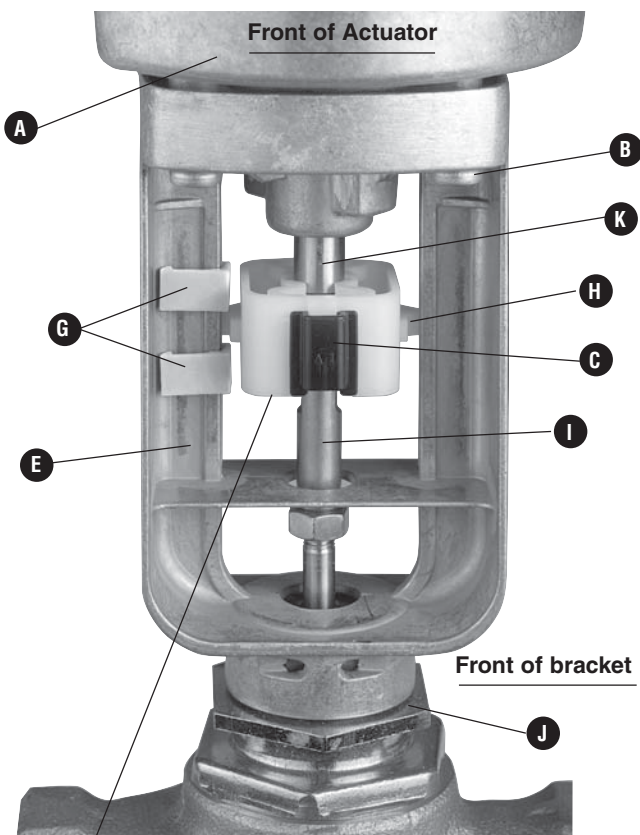

Fig. 2

When disassembling, move the coupling lock (C) up to the unlocked position and squeeze the sides of the coupling while pulling the valve away from the coupling.

#### Recommended Installation Location

It is permissible to install the NV actuator upright or horizontally. However, it is not recommended that the valve stem be installed facing downward. Allow 12 inches of clearance for removal of actuator and 6 inches for removal of actuator cover.

#### Initial Start-up

The unit must not be started up until the valve and actuator have been assembled according to instructions. Adaptation (initialization) will only occur the first time the actuator is powered. To reset, remove housing cover and press adaptation button S2. (See attached set-up information).

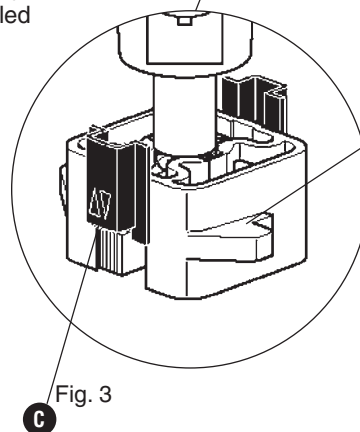

Fig. 3

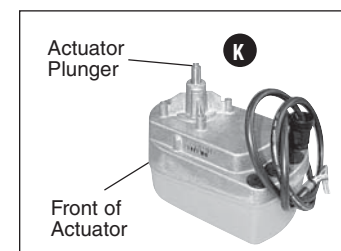

Fig. 4

## Operation/Installation UNV-003 to UNV-051 Series

### Preparing The Valve

#### Kits with Threaded Collars

##### UNV-005, UNV-007, UNV-008 UNV-009, UNV-035, UNV-040, UNV-051

1. Remove all existing linkage from the valve.
2. Push stem into the fully down position.
3. Screw the Collar onto the valve neck and tighten. \*Flats should be on the top for UNV-008 UNV-009, UNV-035, UNV-040 and UNV-051.  
Flats should be on the bottom for UNV-005 and UNV-007.
4. Screw the Lock Nut and the Stem Adaptor onto the valve stem. Use chart to determine the correct height of the stem adaptor. (Height is measure from the top of the valve collar to the top of the stem adaptor, when the stem is in the fully down position.)
5. Tighten the Lock Nut against the Stem Adaptor.

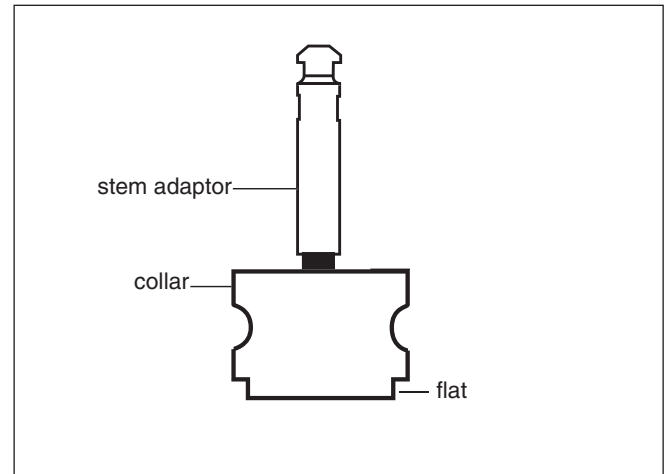

#### Kits with Set Screw Collars

##### UNV-004 and UNV-006

1. Remove all existing linkage from the valve.
2. Push stem into the fully down position.
3. Slide the Collar down over the valve neck and secure in place by installing and tightening the Setscrews. (The threaded Setscrew holes in the collar should be towards the bottom.)
4. Screw the Lock Nut and the Stem Adaptor onto the valve stem. Use chart to determine the correct height of the stem adaptor. (Height is measure from the top of the valve collar to the top of the stem adaptor, when the stem is in the fully down position.)
5. Tighten the Lock Nut against the Stem Adaptor.

#### Kit UNV-003, UNV-013

1. Remove all existing linkage from the valve.
2. Pull the existing slotted stem adaptor into the fully up position.
3. Place Stem Nut (2) over Stem Adaptor (1).
4. Slide Threaded Stopper (3) over existing slotted stem adaptor.
5. Insert Retaining Clip (4) onto existing slotted stem adaptor.
6. Screw and tighten assembly (1,2,3) to existing slotted stem adaptor.

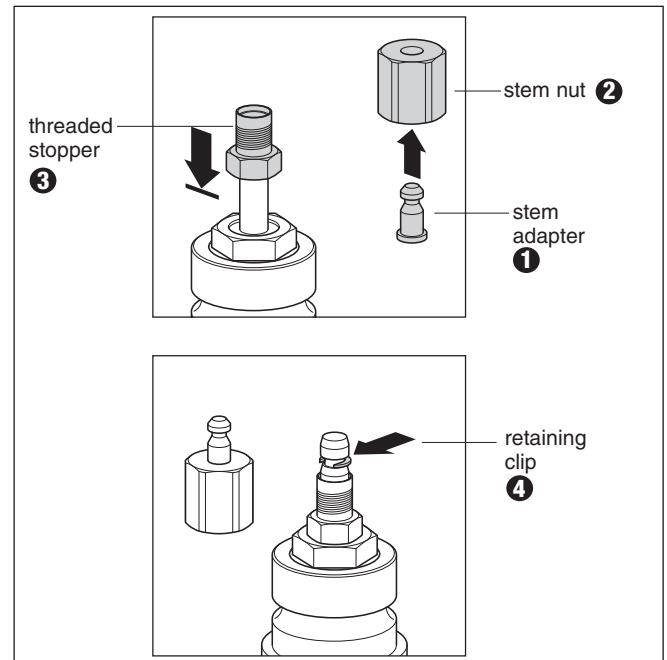

Stem Adjustment	
UNV Number	Height inches [mm]
UNV-001	1.77 [45]
UNV-003	N/A
UNV-004	2.36 [60]
UNV-005	2.56 [65]
UNV-006	2.56 [65]
UNV-007*	2.36 [60]
UNV-008	2.36 [60]
UNV-009	2.56 [65]
UNV-035	2.64 [67]
UNV-040	2.87 [73]
UNV-051	2.56 [65]

\*When retrofitting a V6800 series valve, the stem adjustment is 64 mm.

## Operation/Installation UNV-003 to UNV-051 Series

### Preparing the Actuator and Mounting the Valve All UNV Kits excluding UNV-001

1. Slide the black coupling lock (C) up into the unlocked position. (See Figure 3).
2. Attach Valve Coupling (D) to Actuator Plunger (H). This is done by pushing the bottom of the coupling apart with your thumbs while pressing it on to the actuator plunger. (See Figure 1).
3. Slide the Bracket (E) over the Valve Coupling and the 4 standoffs on the actuator base.
4. Attach the Bracket to the Actuator (A) using 4 Screws (B).
5. Attach Stroke Indicators (G) above and below the valve coupling.
6. Push the valve stem in to the fully down position
7. Use the U-bolt (F) and secure the valve into the bracket, tighten using a 10mm wrench. (U-bolt will fit into the groove in the collar, or the valve neck in the case of UNV-003).
8. Lower plunger (H) using manual override until stem adaptor (I) meets valve coupling. When connected, the valve stem adaptor will be captured by the valve coupling.
9. Slide the coupling lock (C) down in to its locked position.
10. Move Stroke Indicators (G) so that they are directly above and below the valve coupling. They will be automatically repositioned to the maximum stroke when power is applied to the actuator.
11. Set Actuator switches S3.1 and S3.2 to desired setting.

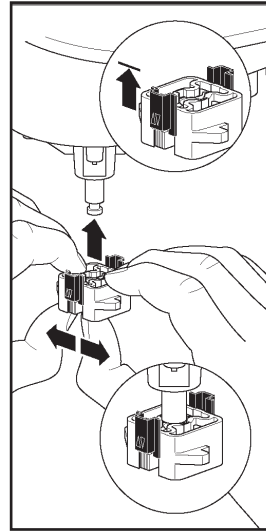

Fig. 1

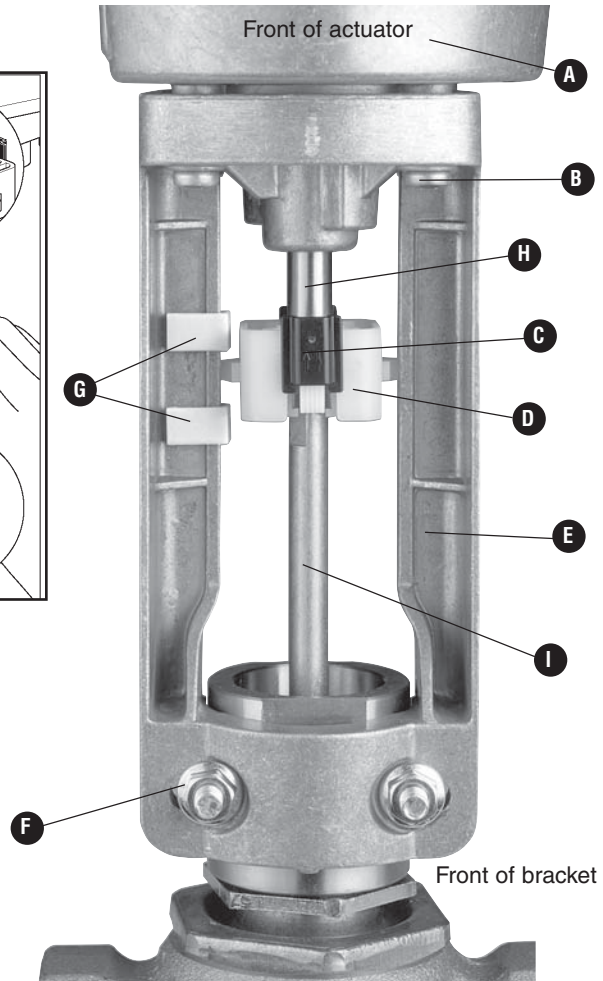

Fig. 2

When disassembling, move the coupling lock (C) up to the unlocked position and squeeze the sides of the coupling while pulling the valve away from the coupling.

### Recommended installation location

It is permissible to install the NV actuator upright or horizontally. However, it is not recommended that the valve stem be installed facing downward. Allow 12 inches of clearance for removal of actuator and 6 inches for removal of actuator cover.

### Initial start-up

The unit must not be started up until the valve and actuator have been assembled according to instructions. Adaptation (initialization) will only occur the first time the actuator is powered. To reset, remove housing cover and press adaptation button S2. (See attached set-up information).

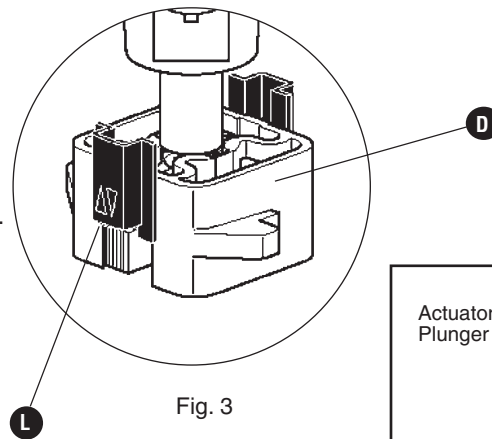

Fig. 3

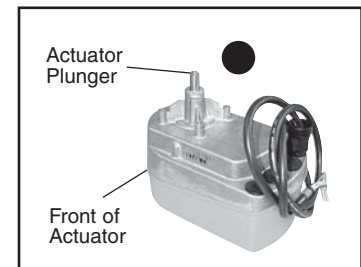

Fig. 4

## Operation/Installation

### Set-Up of NV24-3 US Actuators during Installation

#### General

Beneath the cover of the actuator are the terminals for the cable connection and the S1 switch.

The floating point signal is processed in the microprocessor and conveyed to the motor.

#### Functional Description

**Use Switches S1.1 and S1.2 to set the run time and select the valve closing point**

S1.1	Actuating time	
	Off position	50s/.25" [7.5s/mm]
	(Default)	
	On position	Deactivated not used
S1.2	Selecting the closing point	Valve closing point is with the closing point actuator plunger extended or retracted
	Off position	Valve closing point is with the actuator plunger retracted
	On position	Valve closing point is with the actuator plunger extended

**Note:** NV24-3 US and NVD24-3 US do not contain test or adaptation functional switches. Adaptation is not necessary for the NV24-3 US and NVD24-3 US actuators.

NV24-3 US

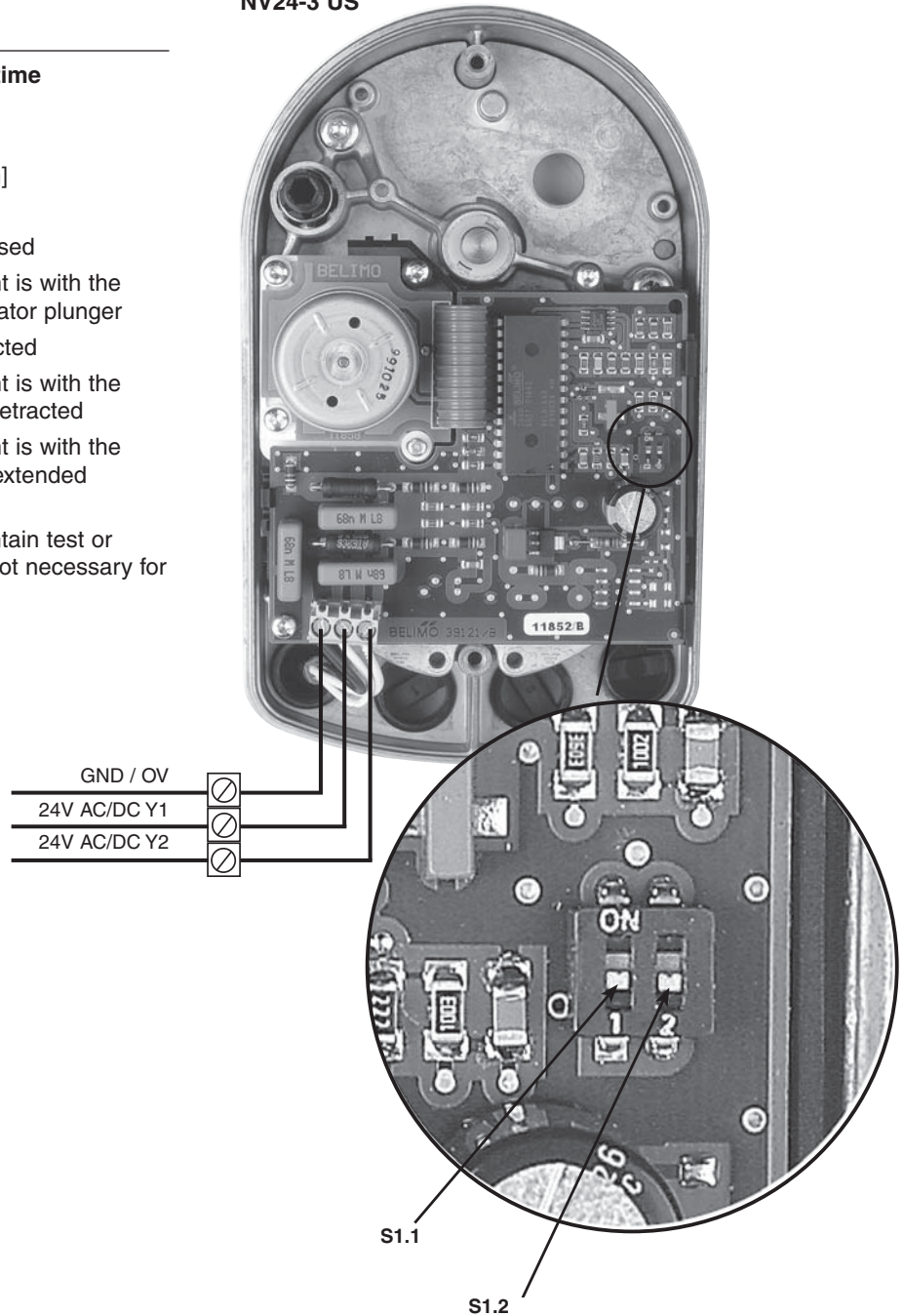

## Operation/Installation

### Set-Up of NV Series MFT Actuators during Installation

#### General

Beneath the cover of the actuator are the terminals for the cable connection, the S1 and S2 buttons, S3 switch, and the LED status display H1.

The setting signal is processed in the microprocessor, and conveyed to the motor via drivers. By setting the slide switch S3 or pressing the buttons S1 and S2, the actuator can easily be configured on site to the requirements, if there are changes from the factory settings.

### MFT and Spring Return Actuators

#### Operation of Switches/LED

##### LED operating display H1

Green steady light	Actuator working properly
Green flashing light	Test run or adaptation with synchronization in progress
Red steady light	Fault; repeat adaptation
Red flashing light	After power interruption (>2 sec.). By the next closing movement the valve will be automatically synchronized in the chosen closing point. The LED indicator will change from a red flashing into green steady light.
Alternating red/green light	Master control system being addressed and operation of the adaptation button S2 in progress

The NV and NVF actuators are maintenance-free. The two-color LED display is located beneath the cover of the actuator. This display allows immediate recognition of the functional state of the actuator. In addition, it permits simple set-up if the factory settings need to be changed.

NV...MFT US  
NVF...MFT US  
NVF...US

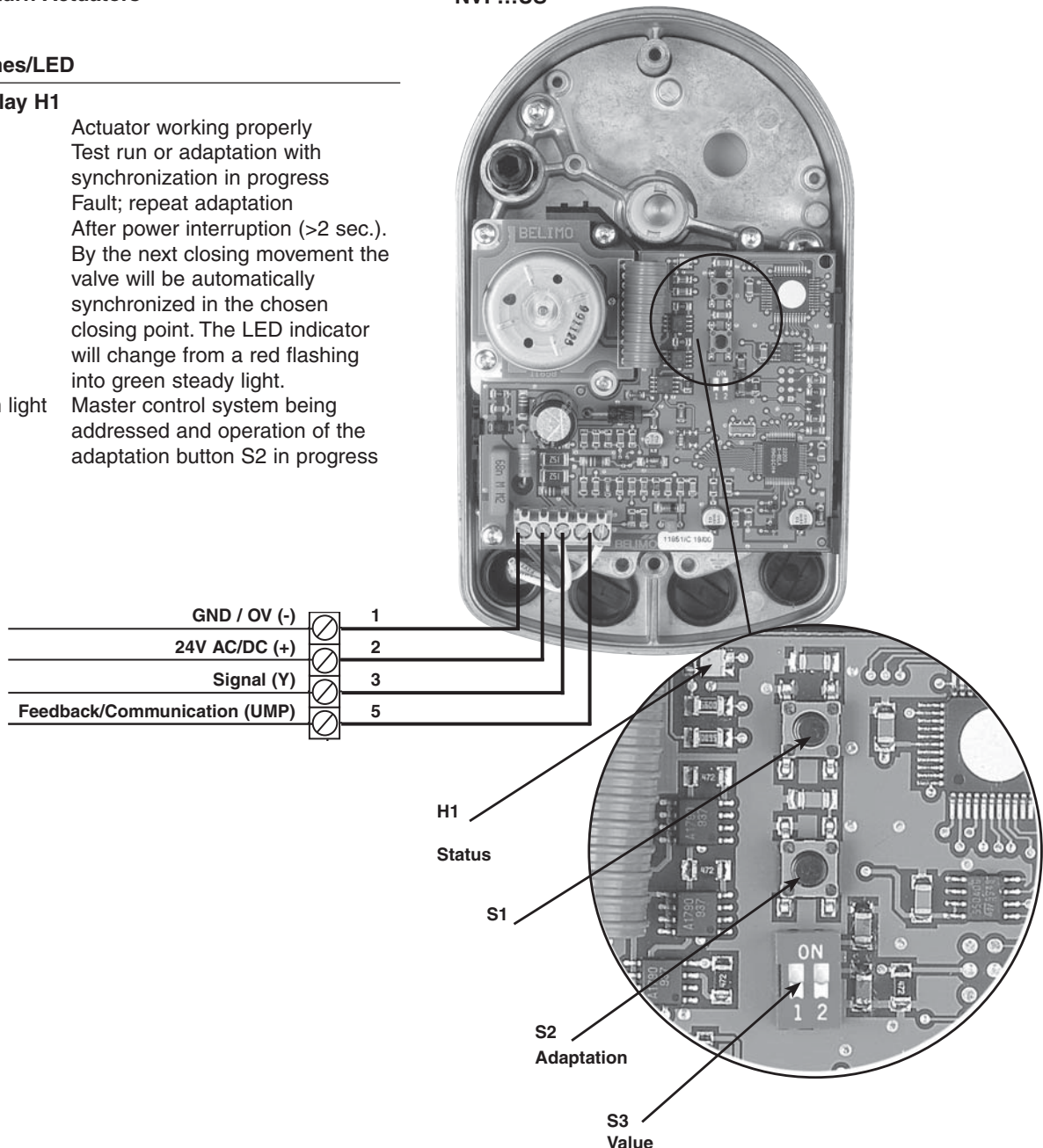

L30043 - 07/09 - SUBJECT TO CHANGE. © BELIMO AIRCONTROLS (USA), INC.

## Operation/Installation

### Manual Override NV...US Non-Spring Return

The valve coupling can be adjusted by inserting a 3/16" or 5 mm hex in the housing cover. (Fig. 3).

If the hex is turned clockwise, the coupling moves down; counterclockwise turning moves it up. The manual override is protected against overload. The coupling remains in the manual position as long as the actuator is not connected to the nominal voltage. With the nominal voltage applied to the actuator, the coupling follows the positioning signal.

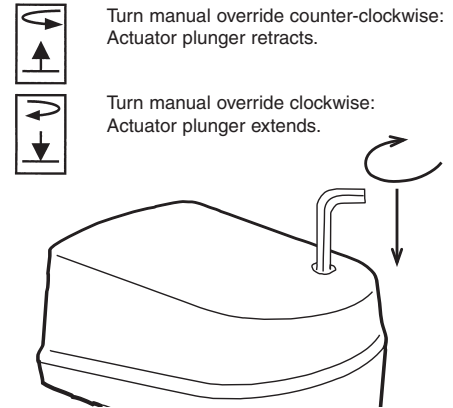

Fig. 3

Over-torquing manual override will not damage actuator.

### Manual Override NVF...US Spring Return

The valve coupling can be adjusted by inserting a 3/16" or 5 mm hex in the housing cover. (Fig. 3).

The spring return function in the actuator is pre-tensioned when delivered. The manual operating mechanism is overload-proof. The plunger will remain at the manual setting until the power supply to the actuator is turned on or, the next time the power supply is interrupted, it moves to whichever end position has been selected.

### NVF...US Retracting, Spring Up

#### ① Disengaging manual operation

Turn the hex clockwise 45° until resistance is encountered. Then lift the key approx. 1/4" [7 mm] until the black socket for the key is level with the top of the housing cover. The spring mechanism will now rotate the key counter-clockwise and the plunger will retract.

#### ② Manual operation

Turning the hex clockwise causes the plunger to extend to the required position.

#### ③ Locking manual operation

Turn the hex 3/4 turn counter-clockwise and then press it down into the cover of the housing (the black socket will move inwards approx. 1/4" [7 mm]). Slight counter-clockwise rotation of the key will then lock the manual operating mechanism in position.

**Note:** Do not trigger the spring mechanism and turn the manual operating mechanism clockwise to the "spring-up" end position at the same time.

#### NOTE:

1. Do not override the NVF while power is applied to the actuator.
2. If the actuator is overridden while power is applied, remove cover and perform manual adaptation function by pressing S2 button.
3. When overriding the actuator turn the hex 3/4 turn and then press down to lock after the desired position is found. This prevents the gear from over-tightening into an end-position which would prevent the override mechanism from unlocking automatically during power up. If the manual override does not unlock automatically during power-up you must unlock the actuator manually with the hex.
4. Use the NV... MFT US in only closed control loops.

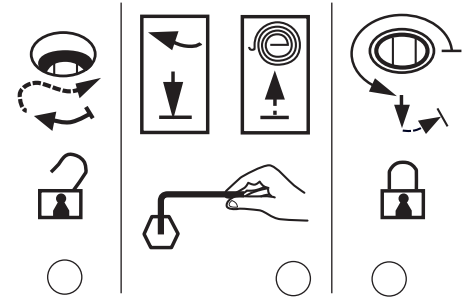

### NVF...-E US Extending, Spring Down

#### ① Disengaging manual operation

Turn the hex counter-clockwise 45° until resistance is encountered. Then lift the key approx. 1/4" [7 mm] until the black socket for the key is level with the top of the housing cover. The spring mechanism will now rotate the key clockwise, the plunger will extend.

#### ② Manual operation

Turning the hex counter-clockwise causes the plunger to retract to the required position.

#### ③ Locking manual operation

Turn the hex back clockwise 3/4 turn and then press it down into the cover of the housing (the black socket will move inwards approx. 1/4" [7 mm]). Slight clockwise rotation of the key will then lock the manual operating mechanism in position.

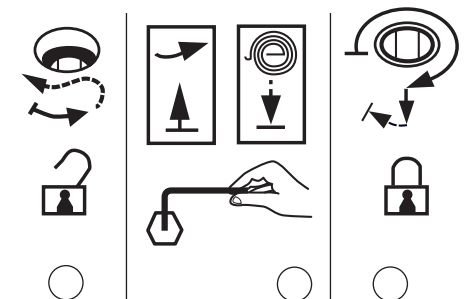

## Operation/Installation

### Functional description NV24-MFT US, NVF... US

The S1 button makes it simple to check the wiring and overall functioning of the actuator. The first time voltage is applied, the stroke is adapted automatically. Independently of this, an adaptation can be repeated as necessary by pressing button S2. Actuator will not do an adaptation after each power loss.

S1	Test	The valve performs full stroke at minimum running time and checks the adapted stroke.
S2	Adaptation	The stroke effected (between the two mechanical end-stops of the valve) is acquired as 100% stroke and stored in the microprocessor. The control signal and running time are then matched to this 100% stroke.

### Set-Up of S3 switches

Note: It is very important to set Switches S3.1 and S3.2 to ensure proper valve operation.

- Determine if the valve body is STEM UP CLOSED or STEM UP OPEN. In other words, when is the valve closed from Ports A to AB– when the stem is up or down?

If the valve is STEM UP OPEN – set Switch S3.2 to the ON position

If the valve is STEM UP CLOSED – set Switch S3.2 to the OFF position

By setting this switch, the actuator will be able to recognize its closing point during the ADAPTATION process.

- Determine if you would like to valve to be Reverse or Direct Acting.

**Direct Acting:** if the valve should be CLOSED at minimum control signal – set Switch 3.1 to the OFF position.

Using this setting, the valve will be CLOSED at minimum control signal and will OPEN as the control signal increases. EX: Closed at 0 Volt signal and Open at 10 Volt signal.

**Reverse Acting:** if the valve should be OPEN at 2 Volts (or minimum control signal) – set Switch 3.1 to the ON position.

Using this setting, the valve will be OPEN at minimum control signal and will CLOSE as the control signal increases. EX: Closed at 10 Volt signal and Open at 2 Volt signal.

**NOTE: The Feedback signal (Wire 5) of the NV Series actuator will follow the closing point of the valve- not the input control signal. In other words, the feedback will always read 2 Volts when the valve is closed regardless if the input control signal is set for Reverse or Direct Acting.**

### S3 Setting the direction of stroke and selecting the closing point

The stroke direction can be adjusted to be reverse or direct acting. Under the factory setting, the stroke increases as the setting signal increases. Depending upon the type of valve (NO/NC), the closing point (stroke = 0%) can be chosen with the valve stem retracted or extended.

S3.1	Direction of stroke	The direction of stroke is inverted in relation to the control signal
	Off position	Control signal = 0% corresponding to 0% stroke
	On position	Control signal = 100% corresponding to 0% stroke
S3.2	Selecting the closing point	This is the closing point of the valve. This is dependent on the valve body-not the actuator. This setting must be correct for proper operation of the actuator.
	Off position	Valve is stem up closed. (Flow from A to AB).
	On position	Valve is stem down closed. (Flow from A to AB).

### EXAMPLES

S3.1 OFF                      At 2 Volts, the valve is closed  
S3.2 OFF                      The valve closing point is STEM UP CLOSED.

Result of Input Signal and Feedback Signal: The valve will be closed at 2 Volts and will open as the actuator drives down. The control signal will read 2 Volts at the closed point and 10 Volts at the fully open point. The feedback will read 2 Volts at the closed point and 10 Volts at the fully open point.

S3.1 ON                        At 2 Volts, the valve is open.  
S3.2 OFF                      The valve closing point is STEM UP CLOSED.

Result of Input Signal and Feedback Signal: The valve will be fully open at 2 Volts and will close as the actuator retracts. The control signal will read 10 Volts at the closed point and 2 Volts at the fully open point. The feedback will read 2 Volts at the closed point and 10 Volts at the fully open point.

S3.1 OFF                      At 2 Volts, the valve is closed  
S3.2 ON                        The valve closing point is STEM DOWN CLOSED.

Result of Input Signal and Feedback Signal: The valve will be closed at 2 Volts and will open as the actuator retracts. The control signal will read 2 Volts at the closed point and 10 Volts at the fully open point. The feedback will read 2 Volts at the closed point and 10 Volts at the fully open point.

S3.1 ON                        At 2 Volts, the valve is open.  
S3.2 ON                        The valve closing point is STEM DOWN CLOSED.

Result of Input Signal and Feedback Signal: The valve will be open at 2 Volts and will close as the actuator drives down. The control signal will read 10 Volts at the closed point and 2 Volts at the fully open point. The feedback will read 2 Volts at the closed point and 10 Volts at the fully open point.