

ICM222 LOCKOUT PROTECTION MODULE



The ICM222 is a low cost lockout protection module that monitors pressure/flow switch inputs and provides anti-short cycle/lockout protection.

Features

- Anti-short cycle/lockout control
- Pressure/flow switch monitoring
- Alarm output during lockout
- 5-minute anti-short cycle delay (5-second test mode)
- LED fault codes for lockout status
- Test mode for reduced test time
- Conformally coated for moisture protection

Mode of Operation

The control will begin the 5-minute time delay upon a Y call from the thermostat. After the time delay expires, the compressor contactor will be energized as long as the high and low pressure switches are closed. If either switch is open after the delay expires, the compressor will not energize. If either switch opens while the compressor is energized, it will de-energize immediately and begin the anti-short cycle delay. The compressor will not be allowed to turn on again until the anti-short cycle delay expires and both pressure switches are closed. The flow switch will have a 30-second bypass timer in which the control will ignore an open flow switch for the first 30-seconds. If the flow switch remains open after the 30-second bypass timer expires, the unit will de-energize the compressor and begin the anti-short cycle delay. If the control experiences three high pressure, low pressure, or flow switch faults in a 60-minute period, it will lockout the compressor and energize the fault output. A manual reset of power will be required to reset the lockout condition.

The control has a status LED to indicate which type of fault or lockout has occurred. If a high pressure fault or lockout occurs, the status LED will blink once. If a low pressure fault or lockout occurs, the status LED will blink twice. If a flow switch fault occurs, the status LED will blink three times.

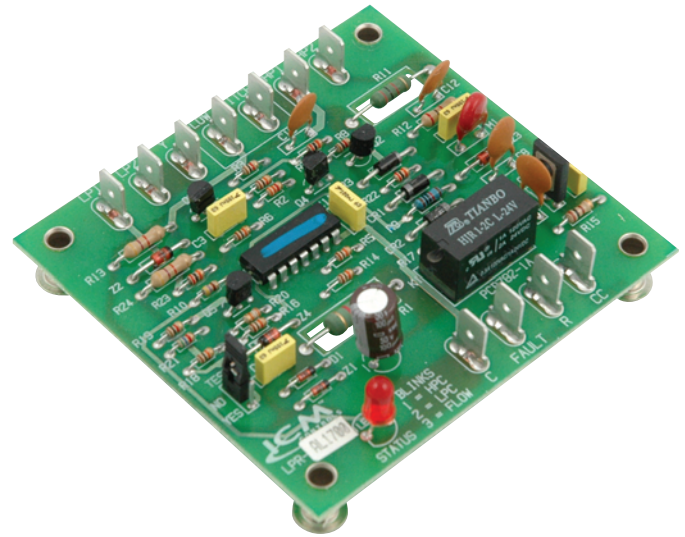

Specifications

Input

- Voltage: 18 to 30 VAC
- Frequency: 50 to 60 Hz

Outputs

- CC
 - Type: Solid state (Triac)
 - Rating: 1 amp @ 30 VAC
- Fault
 - Type: Relay (SPDT) N.O.
 - Rating: 1 amp @ 30 VAC

Time Delay

- Anti-short cycle time: 5 minutes fixed $\pm 20\%$ (5-second test mode)

Mechanical

- Board dimensions: 3.5" x 3.25" x 1"
- Mounting: Surface mount using (4) #6 or #8 screws

Wiring Diagram

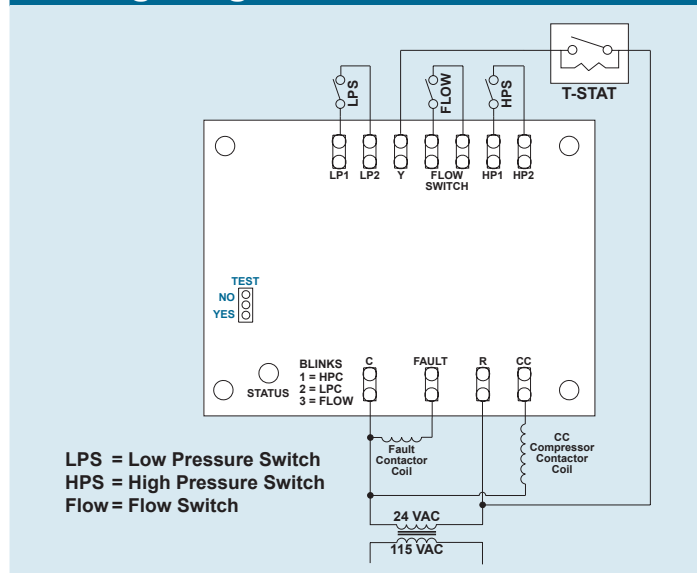

Dimensions

