

SYSTEM CONTROL KIT

Model: CK-43F



Designed for use with the SWG Series Power Venter for controlling Natural Gas or L.P. Gas draft induced appliances.

ITEMS INCLUDED IN KIT

- 1) Junction box with mounted pressure switch and post purge timer
- 1) 2 ft. length of 1/4 inch aluminum tubing
- 2) Flexible conduit connector
- 1) 4" MG1 Barometric Draft Control
- 1) 1/4 inch tubing connector

DO NOT DESTROY

THESE INSTRUCTIONS MUST REMAIN WITH EQUIPMENT



FIELDCONTROLS
THE VENTING SOLUTIONS COMPANY

2630 Airport Road • Kinston, NC 28504
Phone: 252-522-3031 • FAX: 252-522-0214
www.fieldcontrols.com

INSTALLATION

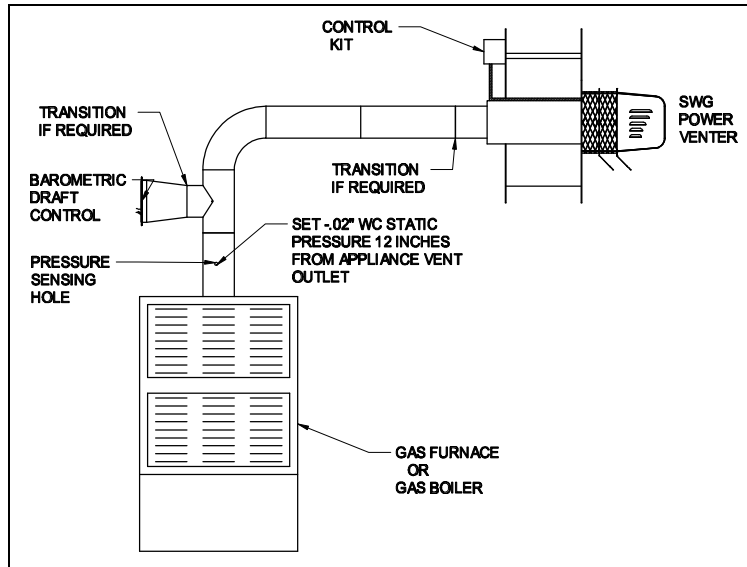

Typical Vent System Layout

MOUNTING JUNCTION BOX

The junction box can be mounted at the venter or remotely mounted away from the venter. (See Figure 1 & Figure 2)

1. Remove one of the knockouts from the side of the junction box where the pressure switch is mounted. Install the flexible conduit connector onto the CK-43F junction box and secure with fastening nut. If remote mounting the CK-43F junction box, mount the flexible conduit connector onto a 2" x 4" installer supplied junction box.
2. Fasten the flexible conduit from the SWG Venter into the conduit connector. Mount the CK-43F junction box or installer supplied junction box onto the wall or floor joist without straining the flexible conduit. Fasten the CK-43F junction box through the four dimpled locations on the base of the box. (See Figure 3)

PRESSURE SWITCH SENSING TUBE INSTALLATION

1. Attach the 1/4 inch tubing connector to the pressure tube on the SWG Venter. (See Figure 3)
2. Connect the supplied 1/4" aluminum tubing to the tubing connector. Route the tubing to the CK-43F junction box and connect the tubing to the pressure switch. When routing the tubing, avoid kinking the tubing by bending the tubing too sharply.

For remote mounted CK-43F Junction Box, use a 1/4" OD copper, aluminum or plastic tubing and route the tubing to avoid contact with any heat source.

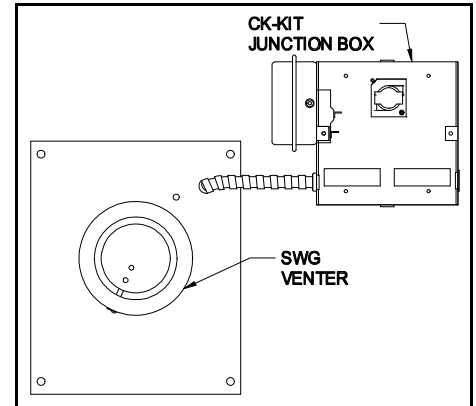

Figure 1

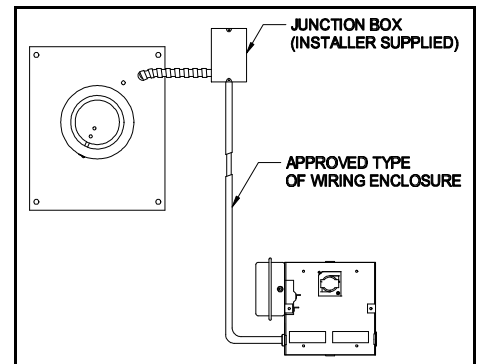

Figure 2

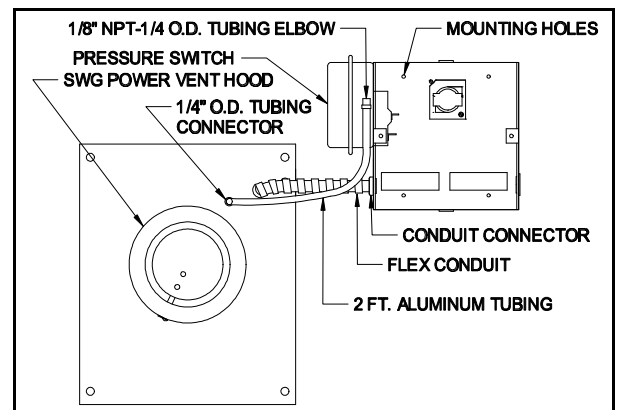

Figure 3

DRAFT CONTROL INSTALLATION

CAUTION: This draft control is shipped as a single acting draft control. If the draft control is not being used on a gas draft induced furnace, remove the gate stop on the draft control ring before installing.

COLLAR INSTALLATION

This control is shipped with a collar patterned to fit a single wall round vent pipe. To attach this collar to the flue, see Figure 4 and follow the instructions below.

1. Bend outward the two ears at the front corners of the collar. Bend 90 degrees, 1/4 inch behind the single hole on the straps.
2. Insert clamping screw in ears on collar and bolt the remainder of the collar together.
3. Hold the collar against the side of the flue in the exact position it is to be installed (shown by dotted lines) and mark the outline of the collar on the flue.
4. Cut a hole in the flue about 1/2" inside of this outline.
5. Make a series of cuts about 1/2" apart from the edge of this hole to the outline marks.
6. Strap the collar to the flue pipe.
7. Bend the tabs formed by the series of cuts outward against the inside of the collar to make a tight joint.
8. Insert the draft control. (See Draft Control Installation and Adjustment Section.)

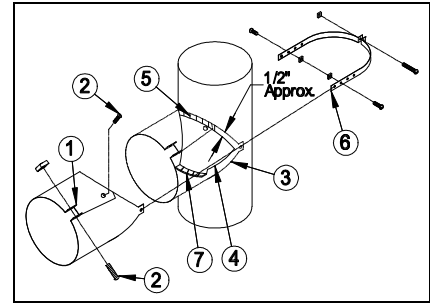

Figure 4

DRAFT CONTROL INSTALLATION IN TYPE B VENT PIPE

CAUTION: DO NOT use the supplied collar when mounting draft control to Type B Vent Pipe. Install by using a Type B Vent Pipe Tee.

1. Install a vent pipe reducer or increaser into the inner pipe and fasten using sheet metal screws. (See Figure 5)
2. The opening of the Type B Vent Tee, at the draft control mounting location, should be sealed with a high temperature sealant or equivalent.
3. Refer to Draft Control Installation Section.

DRAFT CONTROL INSTALLATION

Insert the draft control into the collar or tee. The front face of the control MUST be plumb and the bearing surfaces MUST be level whether the control is on a horizontal, vertical or sloping flue pipe.

Use a spirit level and level accurately. (See Figure 5) Secure the control in the collar by tightening the clamping screws. If a tee is used or a collar is supplied locally, the control may be held in place by sheet metal screws.

ADJUSTING THE DRAFT CONTROL WITH 4" MG1

The control MUST be adjusted to the desired draft setting by adding or removing the washer-type weights supported by the two chains on the side of the draft control. (See Figure 6) DO NOT move the weight attached directly to the gate, this is used only for balancing at the factory.

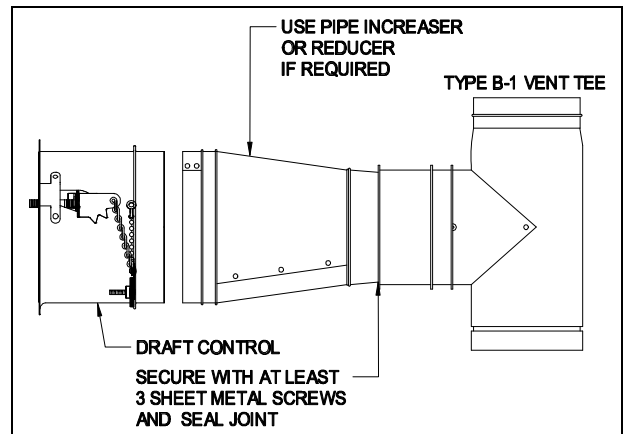

Figure 5

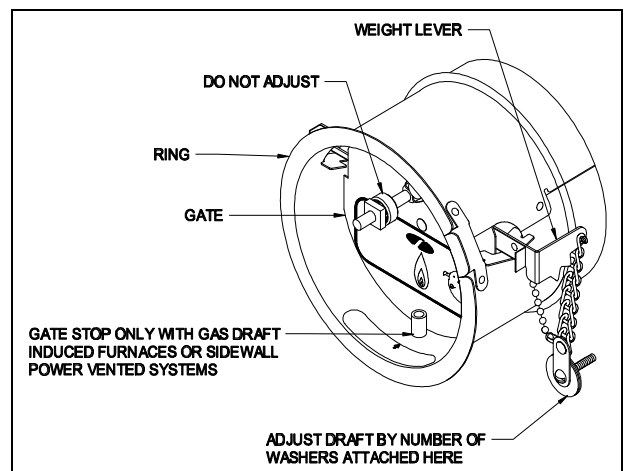

Figure 6

WHAT DRAFT SETTING TO USE

When adjusting the control, two things are essential:

1. The burner must be operating for at least 10 minutes to obtain maximum chimney draft.
2. An analysis of the flue gases is necessary to determine the percentage of CO₂ and check for presence of CO.

Refer to the appliance instructions and/or to the local gas company for the proper CO₂ readings and allowable CO levels. A rule of thumb for draft setting is between .01" to .03" of water column draft at the appliance outlet. (Check equipment requirement.)

Changes in the adjustment of the 4" MG1 control should be made by adding or removing the washer-like weights (supplied with the control) to or from the weight holder chain assembly. After the control is adjusted, it's action will be entirely automatic, the gate will open or close by itself to correct for changes in the draft that occur in the chimney.

ADJUSTMENTS

PROVING SWITCH ADJUSTMENTS

After proper airflow is established, the pressure switch adjustment is made by turning the pressure switch adjustment screw clockwise (See Figure 7) until burner operation stops. Turn the adjustment screw counterclockwise until burner ignites. Turn the adjustment screw an additional 1/4 to 3/4 turn counterclockwise to ensure adequate switch adjustment.



WARNING: Failure to properly adjust the pressure switch as specified above could lead to improper operation of the pressure switch which will result in a hazardous condition and bodily harm!

THERMOSTAT HEAT ANTICIPATOR ADJUSTMENT

After venting kit installation and checkout, check the amperage current draw through the thermostat circuit and adjust the thermostat anticipator accordingly.

WIRING

CAUTION: Disconnect electrical power when wiring power venter.

Wire the venter motor and controls in accordance with the National Electrical Code, manufacturer's recommendations and/or applicable local codes. UNITS MUST BE GROUNDED. Check ground circuit to make certain that the unit has been properly grounded. The wiring should be protected by an overcurrent circuit device rated at 15 amperes. CAUTION must be taken to ensure that the wiring does not come into contact with any heat source. All line voltage and safety control circuits, between the venter and the appliance, MUST be wired in accordance with the National Electrical Code for class one wiring or equivalent methods. Route the venter motor and control wiring with an appropriate wiring method. Refer to Wiring Diagrams A and B.

LOW VOLTAGE WIRING INSTRUCTIONS FOR BOILERS AND WARM AIR FURNACES

1. With boilers, locate terminal on spark ignition module or gas valve (if standing pilot) which would normally be 24 volts hot on a call for heat. With spark ignition systems, this terminal could be TH-W, 24 V, THS or T1 depending on the spark ignition control.
2. With warm air furnaces, locate terminal W in furnace junction box.
3. Remove wire from this terminal and reroute to T1 on CK-43F.
4. With boilers, connect T3 on CK-43F to hot side of gas valve (if standing pilot) or to terminal TH-W, 24 V, THS or T1 if spark ignition.

NOTE: Remember, the correct terminal is the one that would normally be hot on a call for heat.

5. With warm air furnaces, connect T3 on CK-43F to terminal W in furnace junction box.
6. Connect T2 on CK-43F to a 24 volt neutral where convenient.

LINE VOLTAGE WIRING INSTRUCTIONS

1. Connect 120 volts hot power source wire to terminal L1 on CK-43F.
2. Connect 120 volts neutral power source wire and white wire from venter motor to terminal N on the CK-43F.
3. Connect black wire from venter motor to terminal M on the CK-43F.

Refer to the SWG Venter installation instructions for setting system airflow.

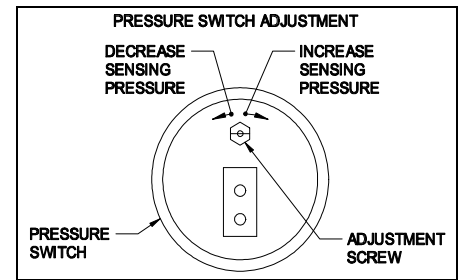

Figure 7

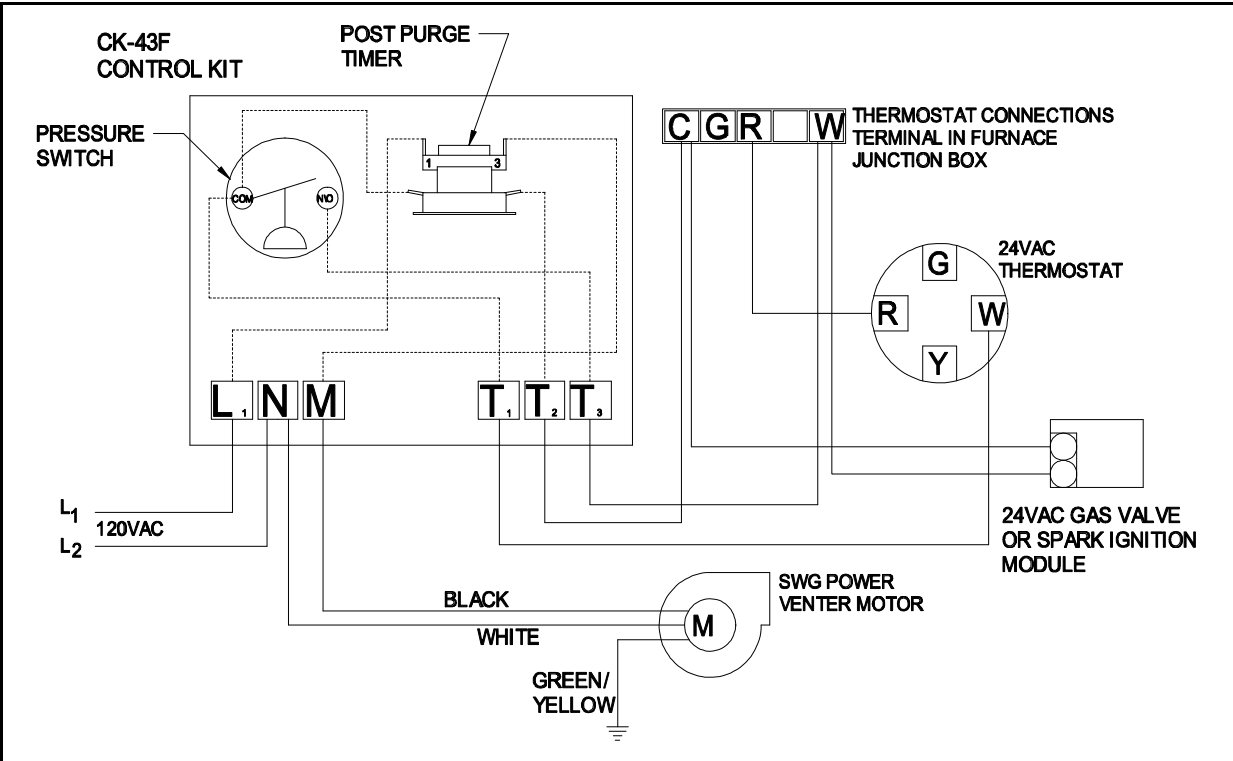

Diagram A

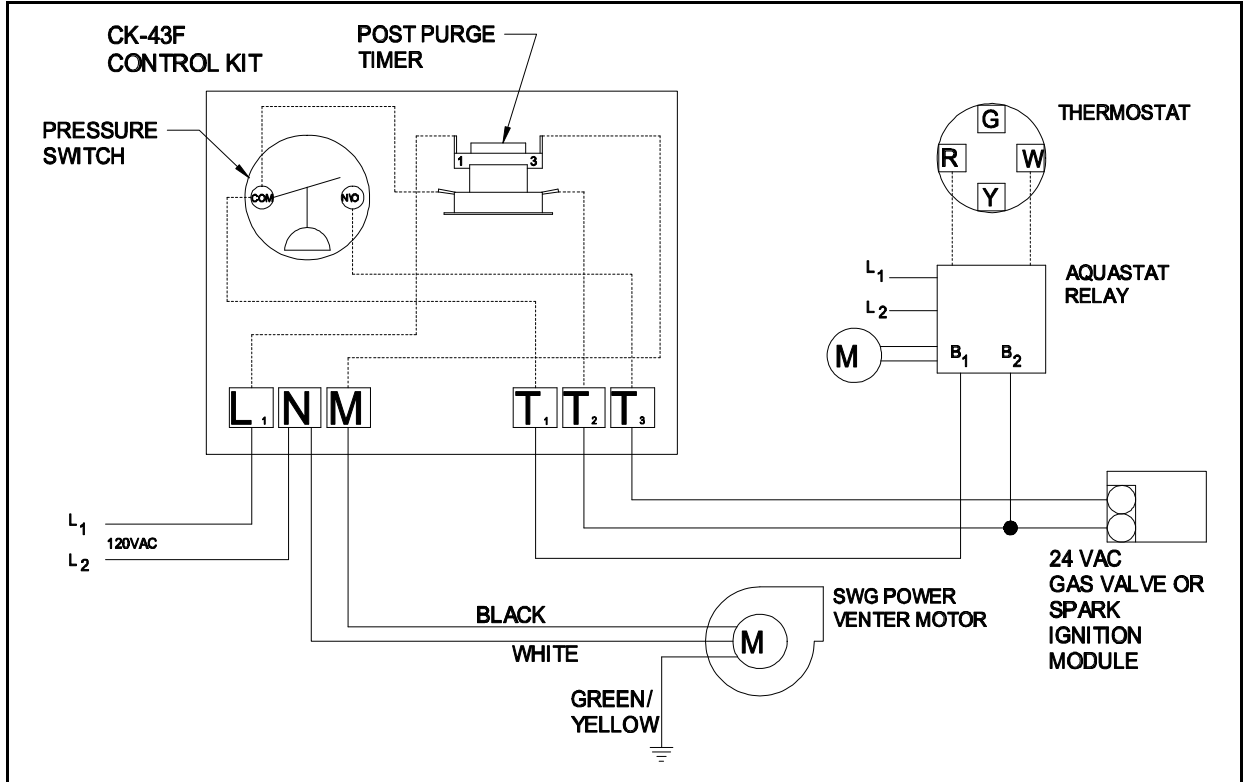

Diagram B

INTERNAL WIRING FOR CK-CONTROL KIT: DIAGRAM A & B	
L1 to 1 on post purge timer	T2 to timer relay base
M to 3 on post purge timer	T3 to N/O on pressure switch
T1 to common on pressure switch	Timer base to common on pressure switch

SYSTEM CONTROL CHECK OUT PROCEDURES

1. For furnaces or boilers, adjust the thermostat to call for heat and observe the power venting system for proper operation sequence. (Repeat if necessary)
 - a. Thermostat calls for heat.
 - b. Relay is energized and venter motor starts.
 - c. Pressure switch closes and burner starts.
 - d. Thermostat is satisfied, the burner stops.
 - e. This starts the post purge cycle. Purge time 1 to 2 min.
2. While system is operating, disconnect power to the venter motor. This should open the pressure switch contacts and stop burner operation.

TROUBLE SHOOTING HINTS

1. Venter does not activate when thermostat calls for heat.
 - a. Check wiring.
 - b. Check gas pressure switch for continuity across terminals when gas valve is pressurized.
 - c. Check gas pressure.
2. Flue gas odor.
 - a. Check system draft.
 - b. Check for negative pressure in building.
3. Pilot will not stay lit on water heater.
 - a. Solder all spillage switch wire terminal connections.
 - b. Check reset buttons on spillage switches.

REPAIR AND REPLACEMENT PARTS

REPAIR AND REPLACEMENT PARTS LIST	
<i>DESCRIPTION</i>	<i>PART NUMBER</i>
Pressure Switch	46083000
Post Purge Timer	46282800

INSTALLATION INFORMATION

MODEL NO.: _____ **CK-43F** _____

INSTALLER'S NAME: _____

INSTALLER'S COMPANY: _____

INSTALLER'S PHONE NO.: _____

DATE OF INSTALLATION: _____

