

# Honeywell

## DAMPER LINKAGE

THE Q605F,G,H,J DAMPER LINKAGE CONNECTS A MODUTROL IV MOTOR TO A STANDARD DAMPER OR SET OF DAMPERS TO PROVIDE CONTROL OF DUCT AIRFLOW.

- Q605F used to mount motor externally on duct.
- Q605G used to mount motor inside duct.
- Q605H used to mount motor externally or internally on duct.
- Q605J used to mount motor externally on duct without mounting bracket.
- Linkages include motor mounting bracket (except Q605J), motor crank arm, damper crank arm (except Q605G), and ball joints.
- Adjustable to any desired degree of damper opening.
- Damper crank arms for 1/2 inch damper shaft standard, crank arms for 3/8 or 7/16 inch shaft available.
- Pushrods available in lengths from 12 to 48 inches.
- Motor crank arm adapter available to permit control of 2 or 3 dampers in selected applications where standard linkages cannot be used. (Standard in Q605H1024 SUPER TRADELINE.)

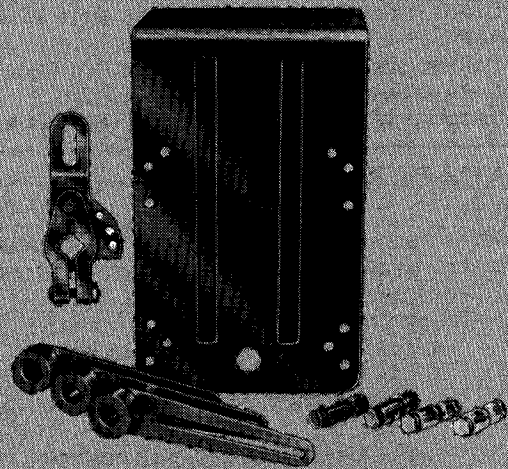

## Q605F,G,H,J

# SPECIFICATIONS

## IMPORTANT

THE SPECIFICATIONS GIVEN IN THIS PUBLICATION DO NOT INCLUDE NORMAL MANUFACTURING TOLERANCES. THEREFORE, THIS UNIT MAY NOT MATCH THE LISTED SPECIFICATIONS EXACTLY. ALSO, THIS PRODUCT IS TESTED AND CALIBRATED UNDER CLOSELY CONTROLLED CONDITIONS, AND SOME MINOR DIFFERENCES IN PERFORMANCE CAN BE EXPECTED IF THOSE CONDITIONS ARE CHANGED.

## SUPER TRADELINE/TRADELINE MODELS

SUPER TRADELINE linkage offers features not available on TRADELINE or standard models, and are designed to replace a wide range of Honeywell and Competitive models. SUPER TRADELINE/TRADELINE models are selected and packaged to provide ease of stocking and handling as well as maximum replacement value. Specifications of SUPER TRADELINE and TRADELINE linkages are the same as those of standard models except as noted below.

### SUPER TRADELINE MODELS AVAILABLE:

Q605H1024 Damper Linkage.

### SUPER TRADELINE FEATURES INCLUDE:

- Left-hand drive ear, Part No. 14000644-004. Assists internal motor mounting.
- Three damper crank arms for 1/2 in. diameter shaft, Part No. 260262G.
- Four ball joints for 5/16 in. pushrod, Part No. 27518.
- Crank arm adapter assembly, Part No. 220767A.
- Permits simultaneous control of two or three dampers as described under ACCESSORIES.
- Template showing installer how to fabricate a

reinforcement plate to strengthen bottom of duct if required for internal mounting.

- Adhesive backed labels indicating damper position (open ad closed), direction (arrow) of air flow, and "Honeywell Energy Management Control System."

### TRADELINE MODELS AVAILABLE:

Q605F1018 Damper Linkage.

### TRADELINE FEATURES:

- Includes the Honeywell Damper Adjustment Guide.
- TRADELINE pack with cross reference label and special instruction sheet.

## STANDARD MODELS

### MODELS:

Q605F—Bracket and linkage for connecting a Modutrol motor to a louver damper when the motor is mounted externally on the duct.

Consists of:

- a. External motor mounting bracket.
- b. Motor crank arm.
- c. Damper crank arm for 1/2 inch diameter shaft.
- d. Ball joints (2) for 5/16 inch pushrod.

Q605G—Bracket and linkage for connecting a

Modutrol motor to a louver damper when the motor is mounted internally.

Consists of:

- a. Internal motor mounting bracket.
- b. Motor crank arm.
- c. Adapter arm for motor crank arm.
- d. Ball joints (2) for 5/16 inch pushrod.

Q605H—Bracket and linkage for connecting one Modutrol motor to two louver dampers when the motor is mounted externally on the duct.

(continued on page 3)

# ORDERING INFORMATION

WHEN PURCHASING REPLACEMENT AND MODERNIZATION PRODUCTS FROM YOUR AUTHORIZED TRADELINE WHOLESALE OR DISTRIBUTOR, REFER TO THE TRADELINE CATALOG OR PRICE SHEETS FOR COMPLETE ORDERING NUMBER, OR SPECIFY—

1. Linkage order number, TRADELINE/SUPER TRADELINE if desired.
2. Pushrod part number.
3. Adapter assembly if desired.
4. Optional damper arm if desired.

IF YOU HAVE ADDITIONAL QUESTIONS, NEED FURTHER INFORMATION, OR WOULD LIKE TO COMMENT ON OUR PRODUCTS OR SERVICES, PLEASE WRITE OR PHONE:

1. YOUR LOCAL HONEYWELL RESIDENTIAL BUILDING CONTROLS SALES OFFICE (CHECK WHITE PAGES OF PHONE DIRECTORY).
2. RESIDENTIAL AND BUILDING CONTROLS CUSTOMER SERVICE  
HONEYWELL INC., 1885 DOUGLAS DRIVE NORTH  
MINNEAPOLIS, MINNESOTA 55422 (612) 542-7500

(IN CANADA—HONEYWELL LIMITED/HONEYWELL LIMITEE, 740 ELLESMERE ROAD, SCARBOROUGH, ONTARIO M1P 2V9) INTERNATIONAL SALES AND SERVICE OFFICES IN ALL PRINCIPAL CITIES OF THE WORLD.

Consists of:

- a. External motor mounting bracket.
- b. Motor crank arm.
- c. Damper crank arms (3) for 1/2 inch shaft.
- d. Ball joints (4) for 5/16 inch pushrod.

Q605J—Linkage for connecting a Modutrol motor to a louver damper when the motor may be mounted directly on a wall or on the outside of the duct without using a mounting bracket.

Consists of:

- a. Motor crank arm.
- b. Damper crank arm for 1/2 inch diameter shaft.
- c. Ball joints (2) for 5/16 inch pushrod.

**ACCESSORIES:**

Pushrods—Pushrods are not included with the linkages and must be ordered separately. All pushrods are 5/16 inch in diameter.

PUSHROD ORDER NUMBER	LENGTH	
	In	mm
27520C-00021	12	304.8
27520D-00021	15	381.0
27520E-00021	18	457.2
27520G-00021	24	609.6
27520K-00021	36	914.4
27520L-00021	48	1219.2

Linkages normally require a pushrod (or rods) of a standard length, as given below, but if it is impossible to determine the necessary length at ordering, choose a long one and cut to length.

LINKAGE	PUSHROD NORMALLY USED
Q605F	27520E (18 in. [457.2 mm])
Q605G	27520D (15 in. [381.0])
Q605H	27520E (18 in. [457.2 mm]) and 27520K (36 in. [914.4 mm])
Q605J	27520E (18 in. [457.2 mm])

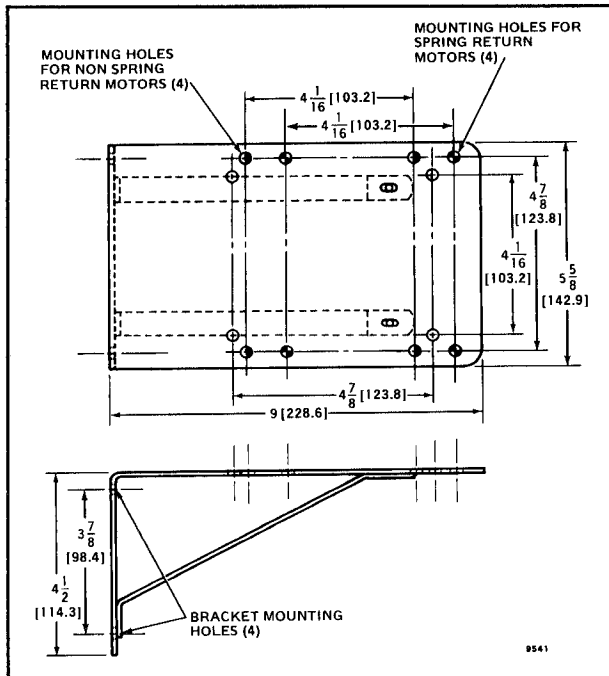

191385 Internal Mounting Kit includes right hand drive ear and bracket.

220767A Adapter Assembly— For use with 106013D crank arm. Permits simultaneous control of:

- a. Two dampers acting at right angles.
- b. Two dampers too far apart to be controlled by standard linkages.
- c. Three dampers, size permitting, ordinarily uncontrollable with standard linkages.

**OPTIONAL SPECIFICATIONS:**

20625B Damper Arm—For 3/8 inch diameter shafts.

27174B Damper Arm—For 7/16 inch diameter damper shafts.

27514B Damper Arm—For 3/4 inch diameter damper shafts.

DIMENSIONS: See Figs. 1-4.

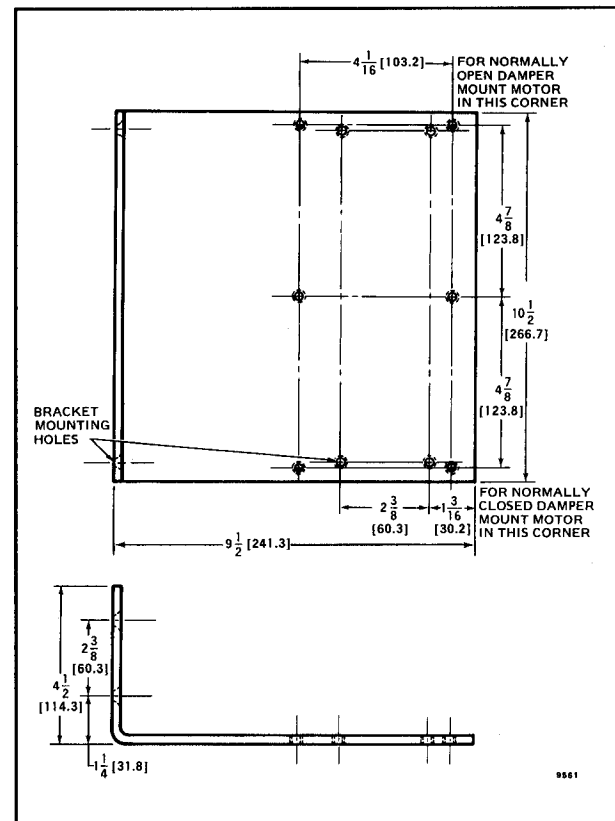
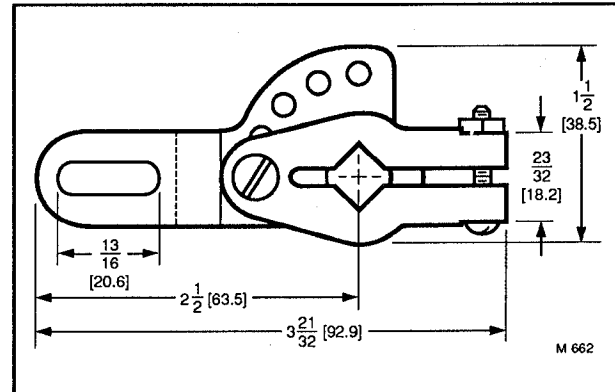

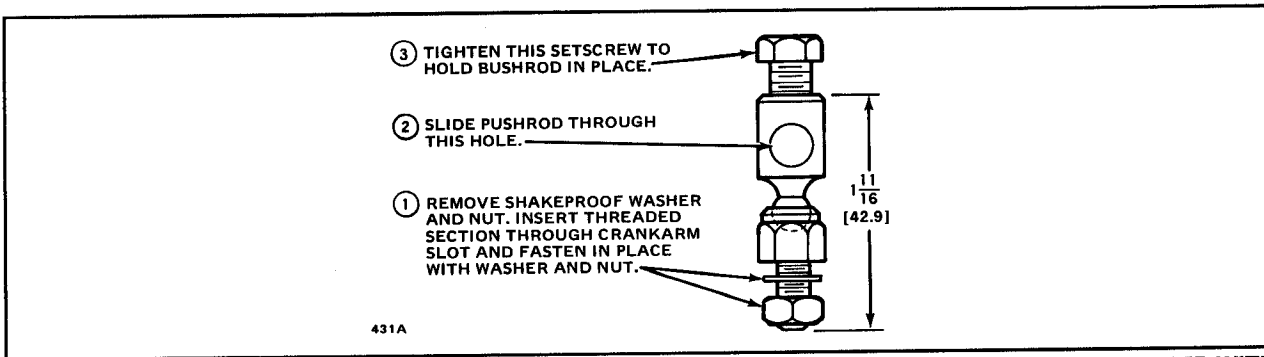

FIG. 4—DIMENSIONS IN ins. [mm IN BRACKETS] AND INSTALLATION OF 27518 BALL JOINTS FURNISHED WITH ALL LINKAGES.

## INSTALLATION

### WHEN INSTALLING THIS PRODUCT...

1. Read these instructions carefully. Failure to follow them could damage the product or cause a hazardous condition.
2. Check the ratings given in the instructions and on the product to make sure the product is suitable for your application.
3. Installer must be a trained, experienced service technician.
4. After installation is complete, check out product

operation as directed in these instructions.

**IMPORTANT**

1. Use a motor with a 160 degree stroke to obtain best possible control of the damper. This type of motor allows the damper to follow changes in the value of the controlled medium more closely.
2. With modulating control, virtually full air flow is achieved at 60 degrees of damper opening.

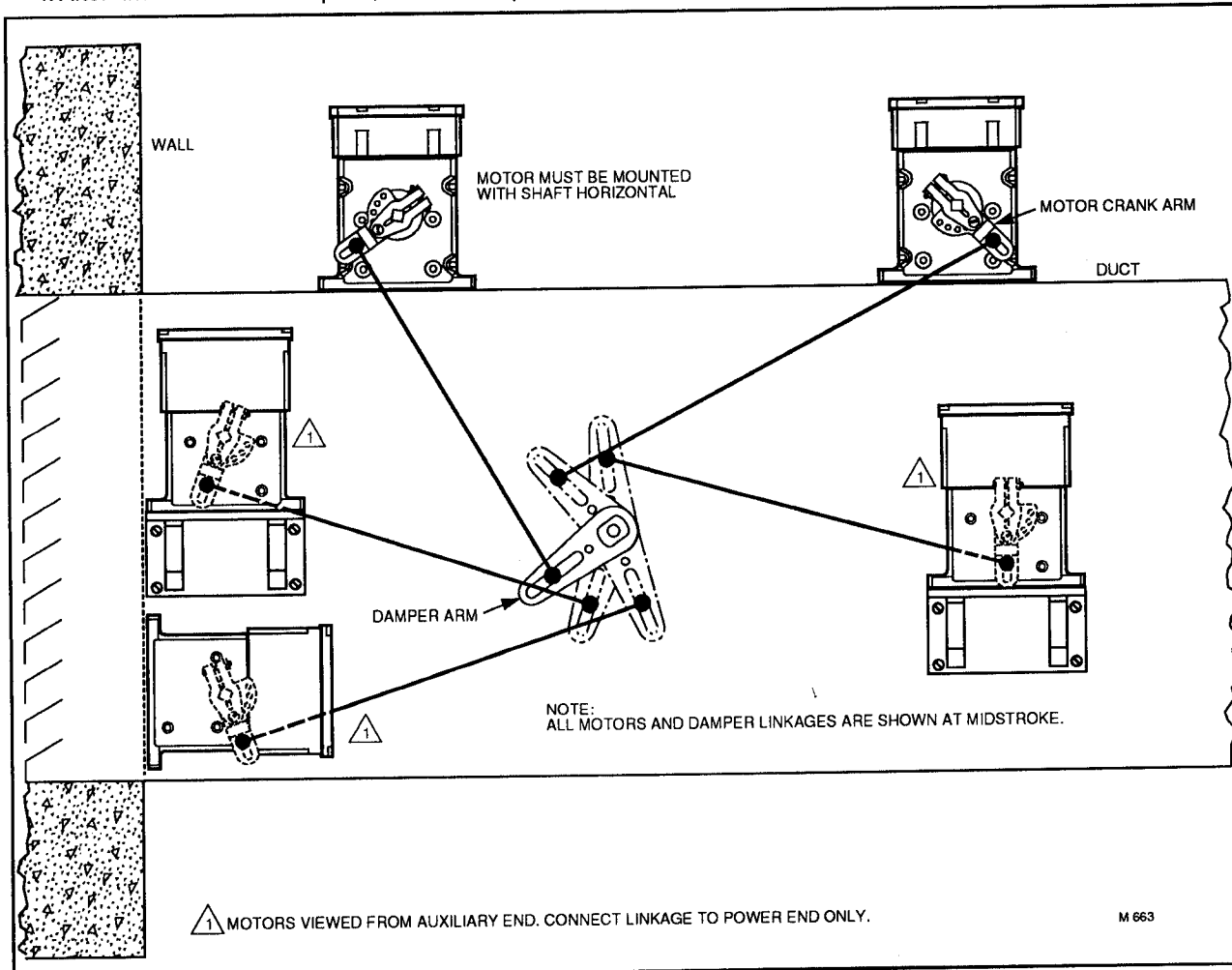

FIG. 5—MODUTROL MOTOR MUST BE MOUNTED WITH SHAFT HORIZONTAL.

**NOTE:** Refer to the applicable Modutrol motor instructions for complete information on motor installation; including location, positioning, and electrical wiring.

### GENERAL CONSIDERATIONS AND PRECAUTIONS

1. The motor crank arm must be permitted to complete its full stroke.
2. The motor must be at its electrical limit of travel when the damper is full open or closed.
3. Too short a pushrod is difficult to adjust.
4. Too long a pushrod is not rigid, resulting in poor damper response.
5. The motor may be mounted in any position as long as the shaft remains horizontal (see Fig. 5).

## CAUTION

The damper must not stop the motor before it has reached its electrical limit. Permanent damage can occur to the motor if it is stopped before reaching its electrical limit of travel.

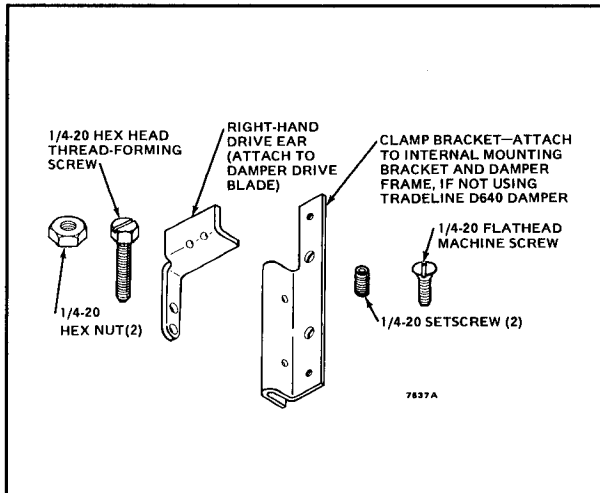

**FIG. 6—PARTS INCLUDED IN 191385 INTERNAL MOUNTING KIT. INTERNAL MOUNTING.**

The Q605H1024 SUPER TRADELINE damper linkage can be used with a TRADELINE D640 damper when the Modutrol motor is required to be mounted within the duct. The Q605H1024 does not include an internal motor mounting bracket. If the duct wall is too thin and flexible to support a motor, make a reinforcement plate to place between the motor and the duct using the template provided as a guide. If a right hand drive ear is required, order part no. 191385. The Q605G standard damper linkage is intended for use with internal motor installations. An internal mounting kit must be ordered to insure proper installation with all D640 type dampers. Order Part No. 191385 (Internal Mounting Kit) from your Honeywell distributor.

#### STEP 1

Attach the drive ear to the damper drive blade (Fig. 8). Tighten the drive ear screw securely. Ensure that the damper blades are in the position they will be at when the motor is at its de-energized electrical limit.

#### STEP 2

Align the shaft holes in the motor crank arm and crank hub. Place the motor crank arm assembly on the motor

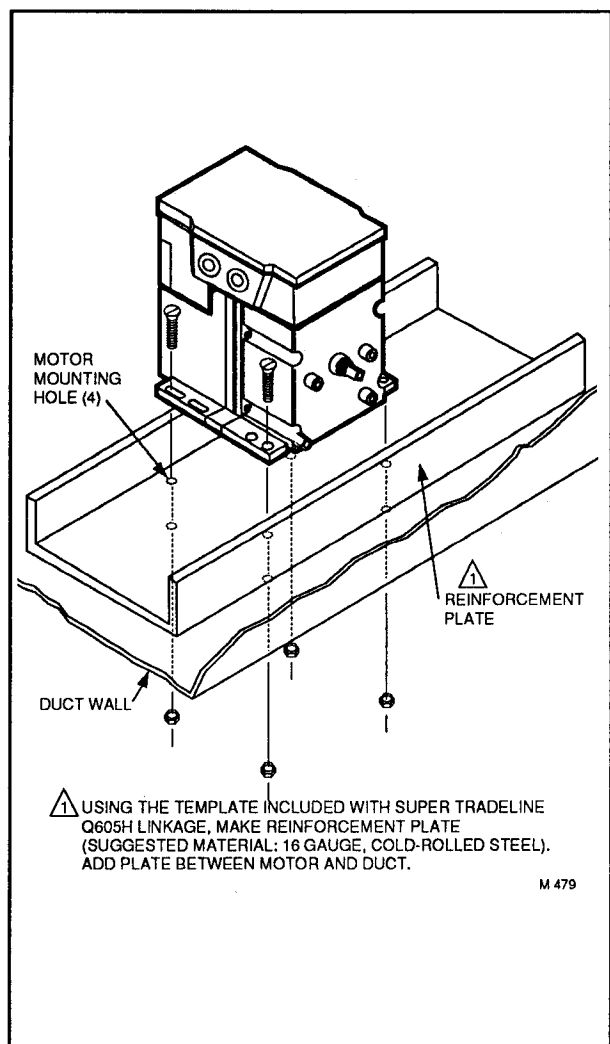

⚠ USING THE TEMPLATE INCLUDED WITH SUPER TRADELINE Q605H LINKAGE, MAKE REINFORCEMENT PLATE (SUGGESTED MATERIAL: 16 GAUGE, COLD-ROLLED STEEL). ADD PLATE BETWEEN MOTOR AND DUCT.

M 479

**FIG. 7—IF MOUNTING A MOTOR INSIDE A THIN WALLED DUCT, ADD A REINFORCEMENT PLATE.**

shaft. Tighten the crank arm screws finger tight because further adjustments will be required. Do not install clip until adjustments are completed (see Fig. 12).

#### STEP 3

Install a ball joint at the innermost position of the motor crank arm; and another at the damper drive ear outermost position. Tighten the fastening hardware securely.

#### STEP 4

Slide the pushrod through the two ball joints and tighten the setscrews finger tight.

### LINKAGE ADJUSTMENT (Internal Motor Installations)

In modulating installations the damper should not open more than 60 degrees, the point at which 96 percent of the maximum air volume passes through the damper. Opening the damper any further will have a negligible effect. Fig. 9 indicates the degrees of damper opening necessary to pass 96 percent of the total air volume at different design duct air velocities. The curve shown is characteristic of a typical parallel blade damper, although it may vary slightly with type of damper and the type of duct work.

### STEP 1

With the damper positioned at the point it would be if the motor was in its midstroke position, slide the motor crank arm off the motor shaft. Keeping it in line with the shaft, rotate the crank arm around the motor shaft axis until the motor crank arm is nearly perpendicular to an imaginary line between the motor shaft and the damper drive blade (see Fig. 10). With the damper still at the midstroke position, tighten setscrews on the ball joints just enough to prevent slippage of the pushrod.

### STEP 2

Rotate the motor crank arm (NOT the motor shaft) clockwise through the remaining half of the motor stroke, this corresponds to the energized limit of shaft rotation. Then rotate the crank arm counterclockwise to the position that corresponds to the motor's de-energized electrical limit of shaft rotation. Perform this several times to verify that the damper and linkage operate freely without binding. When this step is completed, the motor crank arm position should correspond to the de-energized electrical limit of shaft rotation.

**NOTE:** For purposes of reference, clockwise rotation of the motor as seen from the power end is considered the opening stroke, whether this opens or closes the damper depends on the arrangement of the linkage.

### STEP 3

- Place the motor crank arm on the motor shaft to that it corresponds to the de-energized electrical limit of shaft rotation. If necessary reposition the crank arm with respect to the crank hub by removing the adjustment screw and installing it through another hole in the crank arm.
- Insert the clip between the crank arm and crank hub. The motor crank arm positioning screw must be loose to provide clearance.
- Tighten the motor crank arm screw securely (see Fig. 11).

### STEP 4

Operate the motor through its complete stroke. Be prepared to release one of the connections, if necessary to prevent damage. Check for proper operation of the motor, damper, and linkage. There should be no binding and the motor should rotate open and closed smoothly. Watch any excess length of pushrod to make sure that there is no chance of its stalling the motor.

### STEP 5

Make necessary minor adjustments until the desired operation is obtained, then tighten all nuts and screws securely.

### EXTERNAL MOUNTING

The Q605F, Q605H and Q605J damper linkages are used for external motor mounting installations. Mount the motor in any position as long as the shaft is horizontal (see Fig. 5).

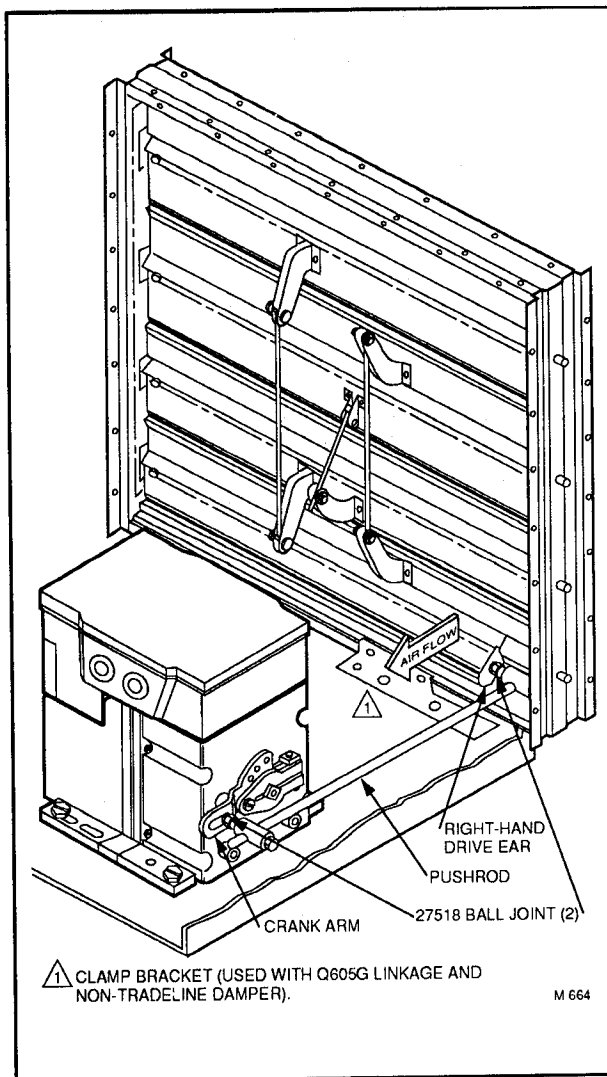

FIG. 8—MOUNTING MOTOR INTERNALLY WITH A HORIZONTAL DAMPER.

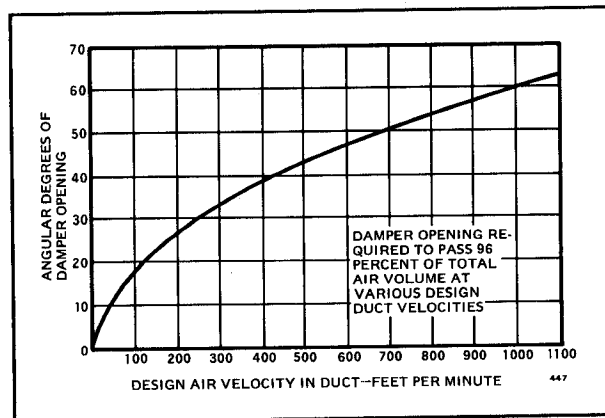

FIG. 9—USE THIS CURVE WHEN DETERMINING INITIAL DAMPER SETTINGS.

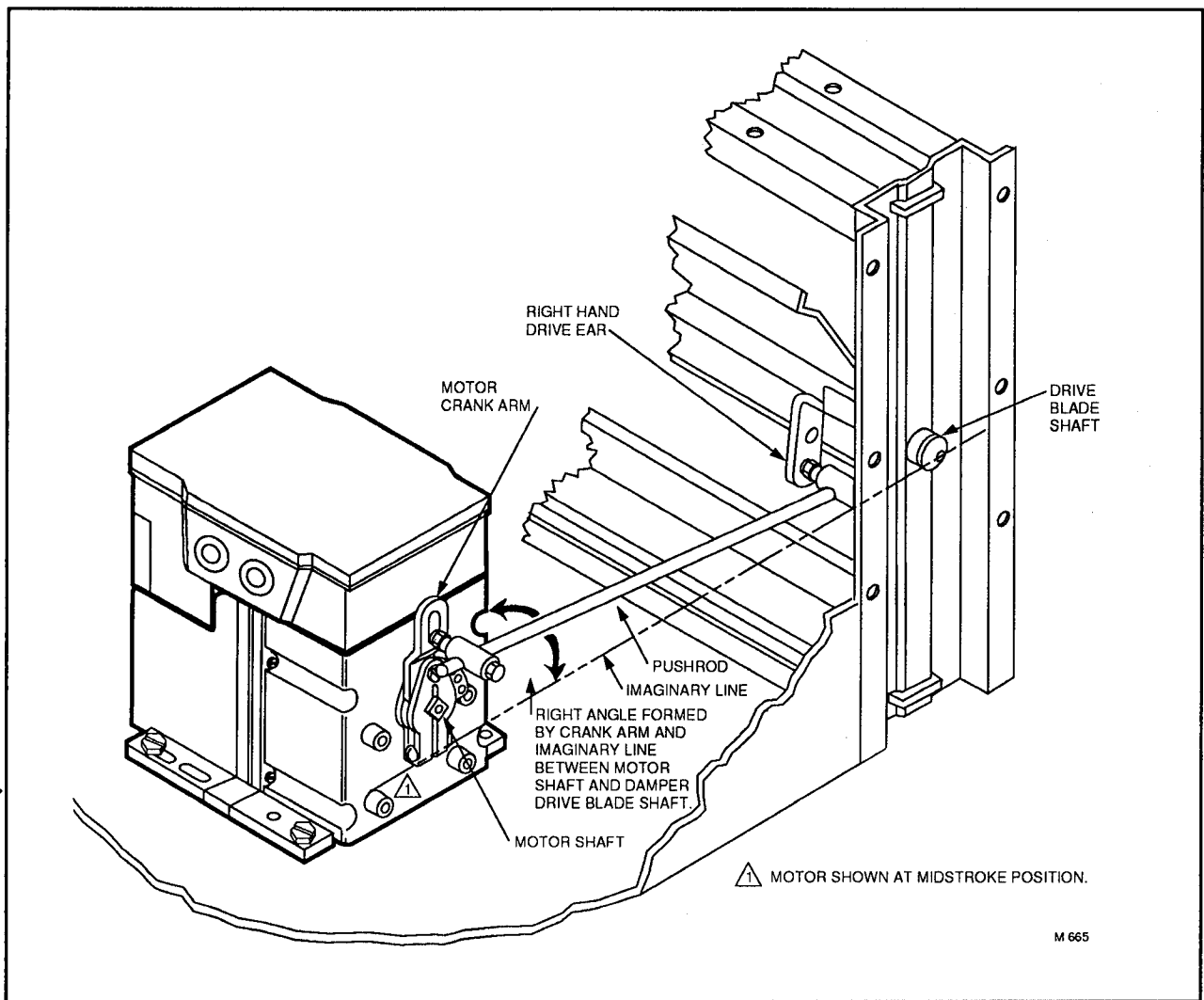

FIG. 10—ORIENTATE MOTOR CRANK ARM TO THE PROPER MIDSTROKE POSITION.

**STEP 1**

Place the crank arm assembly on the motor shaft. Tighten the motor crank arm bolt finger tight, as further adjustments will be required. See Fig. 11.

**STEP 2**

Slip the damper crank arm on the damper shaft, ensure that the damper blades are in the position they will be at when the motor is at its de-energized electrical limit. Tighten the damper crank arm setscrews finger tight because additional adjustments will be necessary.

**STEP 3**

Install one ball joint at the innermost position of the motor crank arm, and another at the desired angular degrees-of-travel mark on the damper crank arm (see Fig. 11). For 90 degree motors, damper crank arm travel will be about half that indicated on the crank arm. On noncalibrated crank arms, approximate the positions shown in Fig. 12 and adjust later.

**STEP 4**

Slide the pushrod through the two ball joints and tighten the ball joint setscrews finger tight.

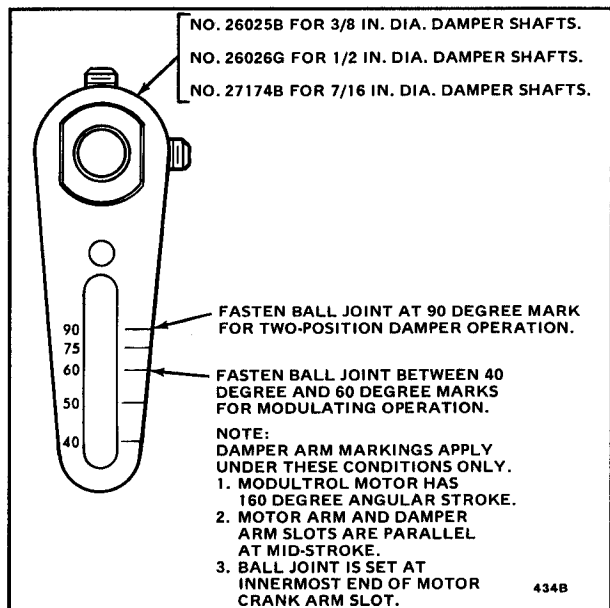

FIG. 11—POSITION BALL JOINT ON DAMPER CRANK ARM.

## LINKAGE ADJUSTMENT

For two-position control, the ball joint should be set at the 90 degree mark of the damper crank arm so the damper will be either fully open or fully closed, depending on the demand of the controller.

In modulating installations, the damper should not open more than 60 degrees, which allows 96 percent of the maximum air volume to pass through the damper. Any additional opening of the damper will have little or no effect.

Fig. 9 indicates the number of degrees of damper opening required to pass 96 percent of the total air volume at various design duct velocities. The curve shown is characteristic of a typical parallel blade damper, although it will vary with the type of damper, the type of duct work.

### STEP 1

With the damper positioned at the point it would be if the motor was in its midstroke position, slide the motor crank arm off the motor shaft. Keeping it in line with the motor shaft, move the motor crank arm around the motor shaft axis and the damper crank arm around the damper shaft until both crank arms are nearly perpendicular to an imaginary line between the motor and damper shafts (see Fig. 12). With the damper still at the midstroke position, tighten the setscrews on the damper crank arm and ball joints enough to prevent slippage.

### STEP 2

Rotate the motor crank arm (NOT the motor shaft) clockwise through the remaining half of the motor stroke, this corresponds to the energized limit of shaft rotation. Then rotate the crank arm counterclockwise to the position that corresponds to the motor's de-energized electrical limit of shaft rotation. Perform this step several times to verify that the damper and linkage operate freely without binding. When the above instructions are completed, the motor crank arm position should correspond to the de-energized electrical limit of shaft rotation.

**NOTE:** For purposes of reference, clockwise rotation of the motor as seen from the power end is considered the opening stroke, whether this opens or closes the damper depends on the linkage arrangement.

### STEP 3

- Place the motor crank arm on the motor shaft so it corresponds to the de-energized electrical limit of shaft rotation.
- Tighten the motor crank arm bolt securely.

### STEP 4

Operate the motor through its complete stroke. Be prepared to release one of the connections, if necessary to prevent damage. Check for proper operation of the motor, damper, and linkage. There should be no binding and the motor should rotate open and closed smoothly. Watch any excess length of pushrod to make sure that there is no change of fouling and stalling the motor.

### STEP 5

Make necessary minor adjustments until the desired operation is obtained, then tighten all nuts and screws securely.

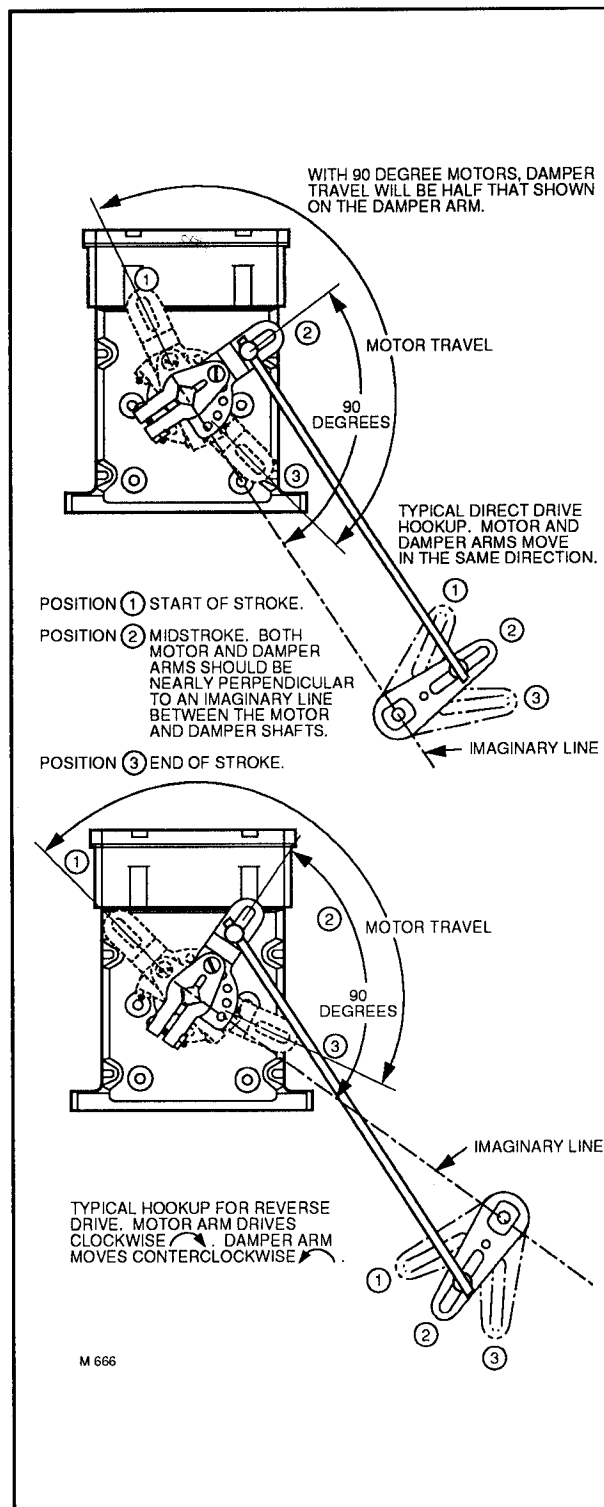

**FIG. 12—POSITIONING THE LINKAGE. NOTE THAT MOTOR ARM POSITIONS SHOWN ARE TYPICAL; THE EXACT POSITION OF THE MOTOR ARM MAY BE ANYWHERE ON THE SHAFT, DEPENDING ON DAMPER LOCATION.**

# TYPICAL INSTALLATIONS

NOTE: For purposes of reference, clockwise rotation of the motor, as seen from the power end, is considered the opening stroke. Whether this opens or closes the damper depends on the arrangement of the linkages.

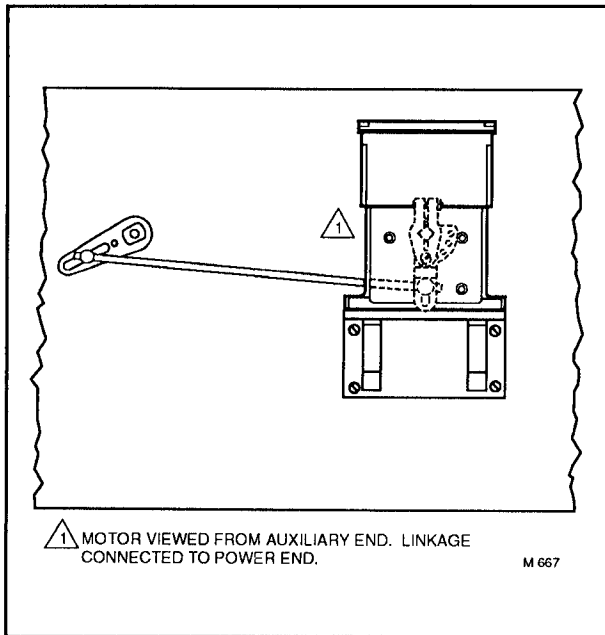

FIG. 13—MODUTROL MOTOR MOUNTED EXTERNALLY ON THE DUCT TO CONTROL ONE DAMPER.

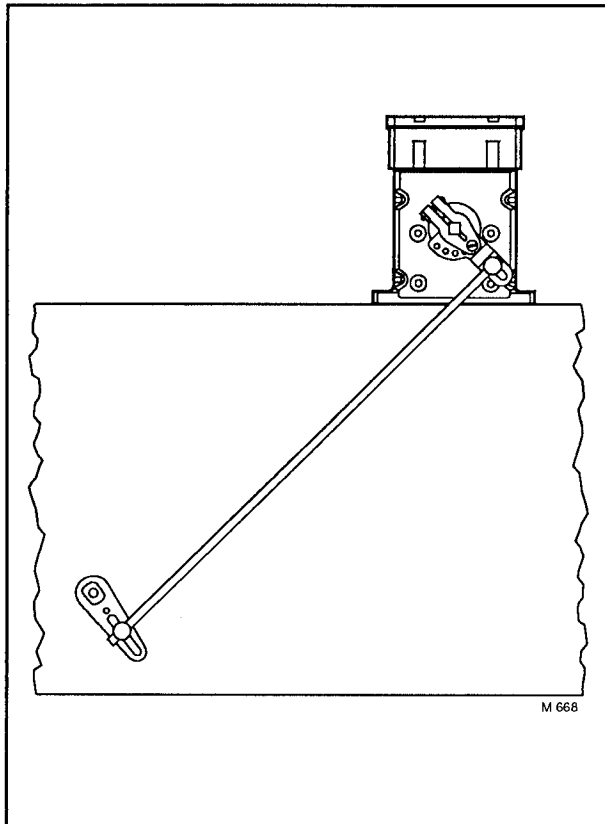

FIG. 14—MODUTROL MOTOR MOUNTED DIRECTLY ON THE DUCT (WITHOUT A MOUNTING BRACKET) TO CONTROL ONE DAMPER.

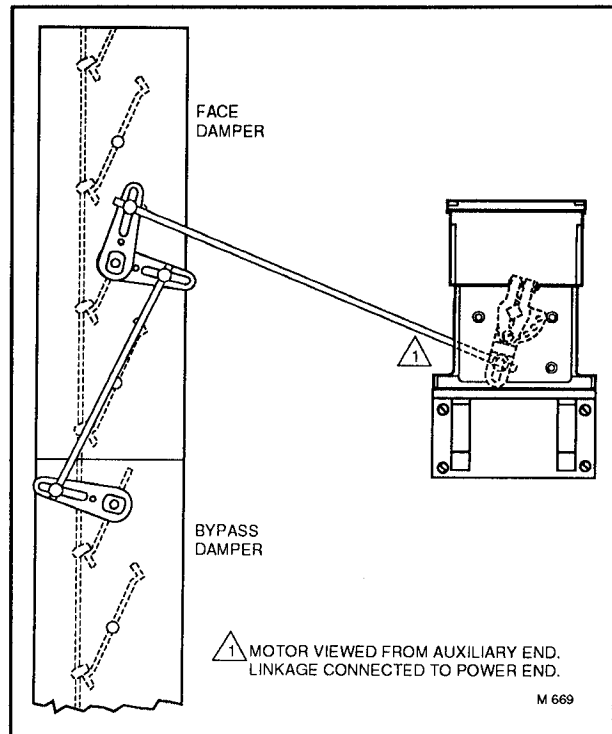

FIG. 15—MODUTROL MOTOR MOUNTED EXTERNALLY TO OPERATE A NORMALLY CLOSED FACE DAMPER AND A NORMALLY OPEN BYPASS DAMPER.

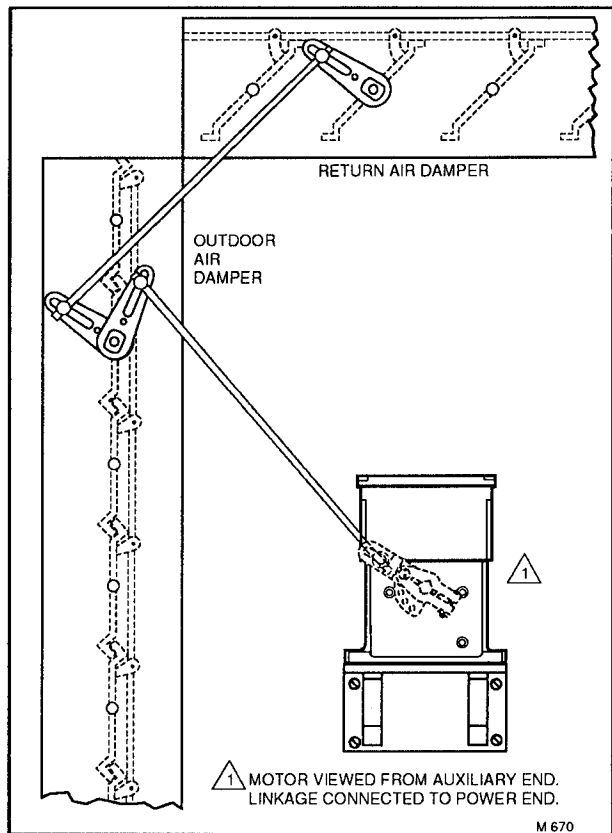
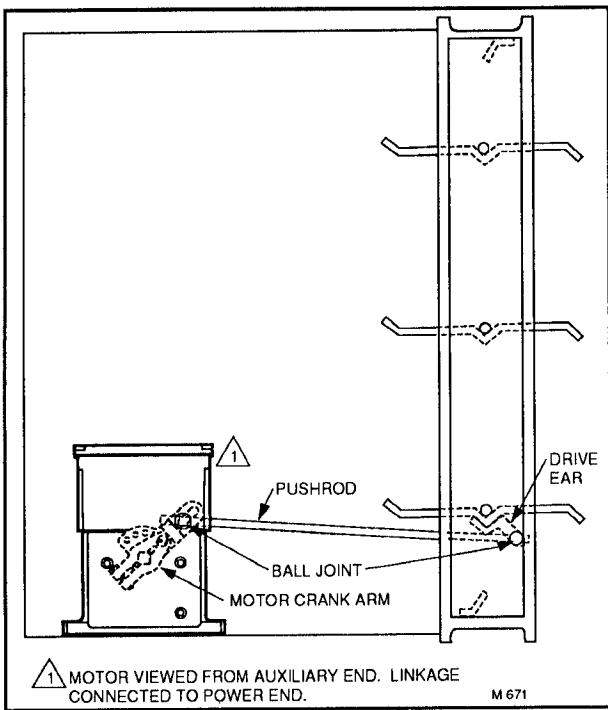
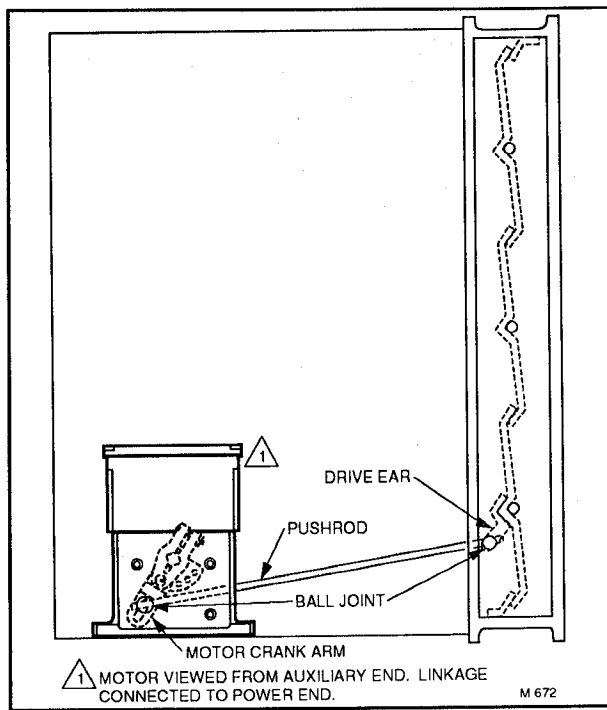

FIG. 16—MODUTROL MOTOR MOUNTED EXTERNALLY ON THE DUCT TO CONTROL TWO DAMPERS ACTING AT RIGHT ANGLES.



**FIG. 17—TWO-POSITION OPERATION (WITHOUT ADAPTER ARM) OF A NORMALLY CLOSED DAMPER.**



**FIG. 18—TWO-POSITION OPERATION (WITHOUT ADAPTER ARM) OF A NORMALLY OPEN DAMPER.**

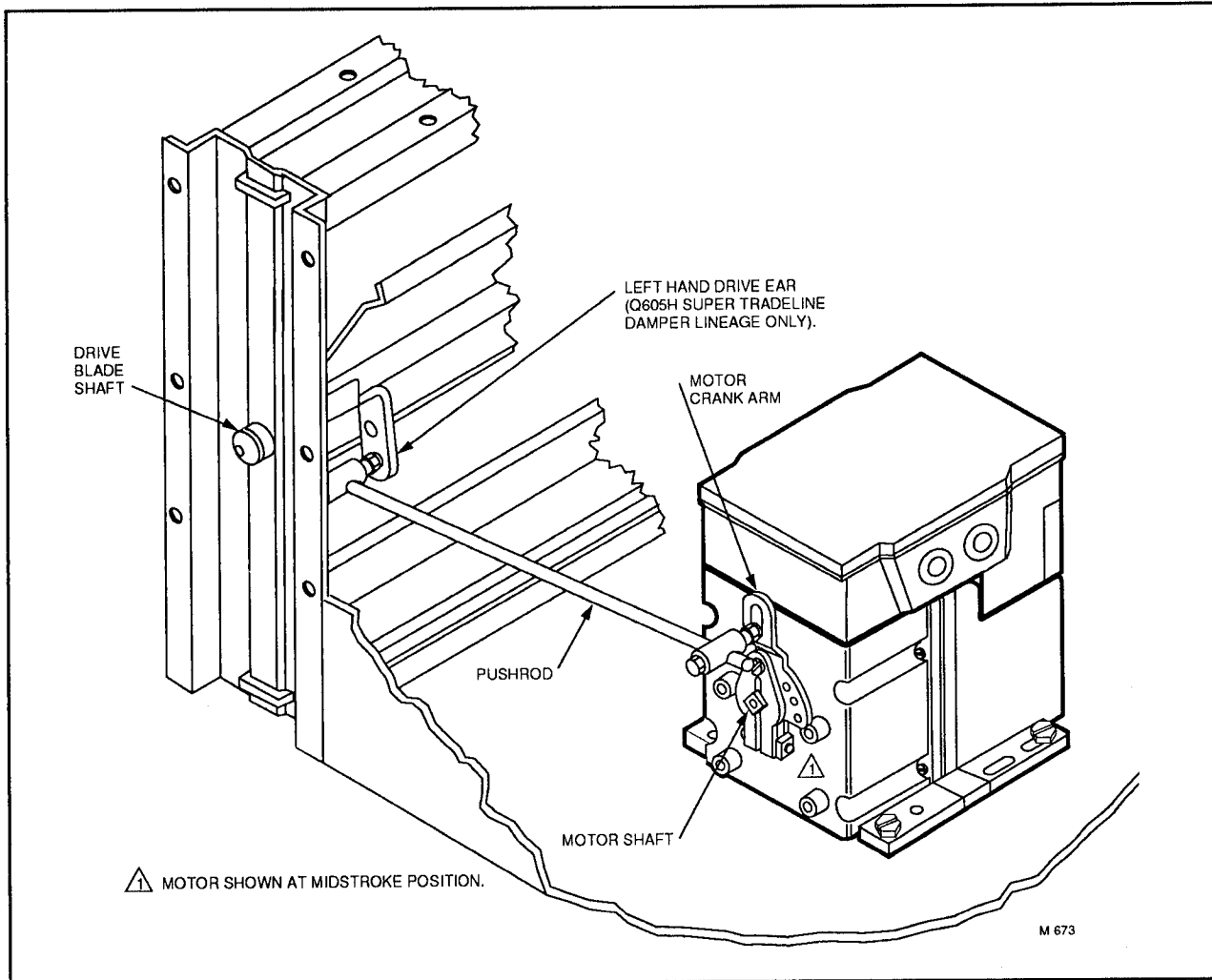

**FIG. 19—MODULATING OPERATION OF A NORMALLY OPEN DAMPER, POSITION ADAPTER ARM SAME AS CRANK ARM ABOVE.**

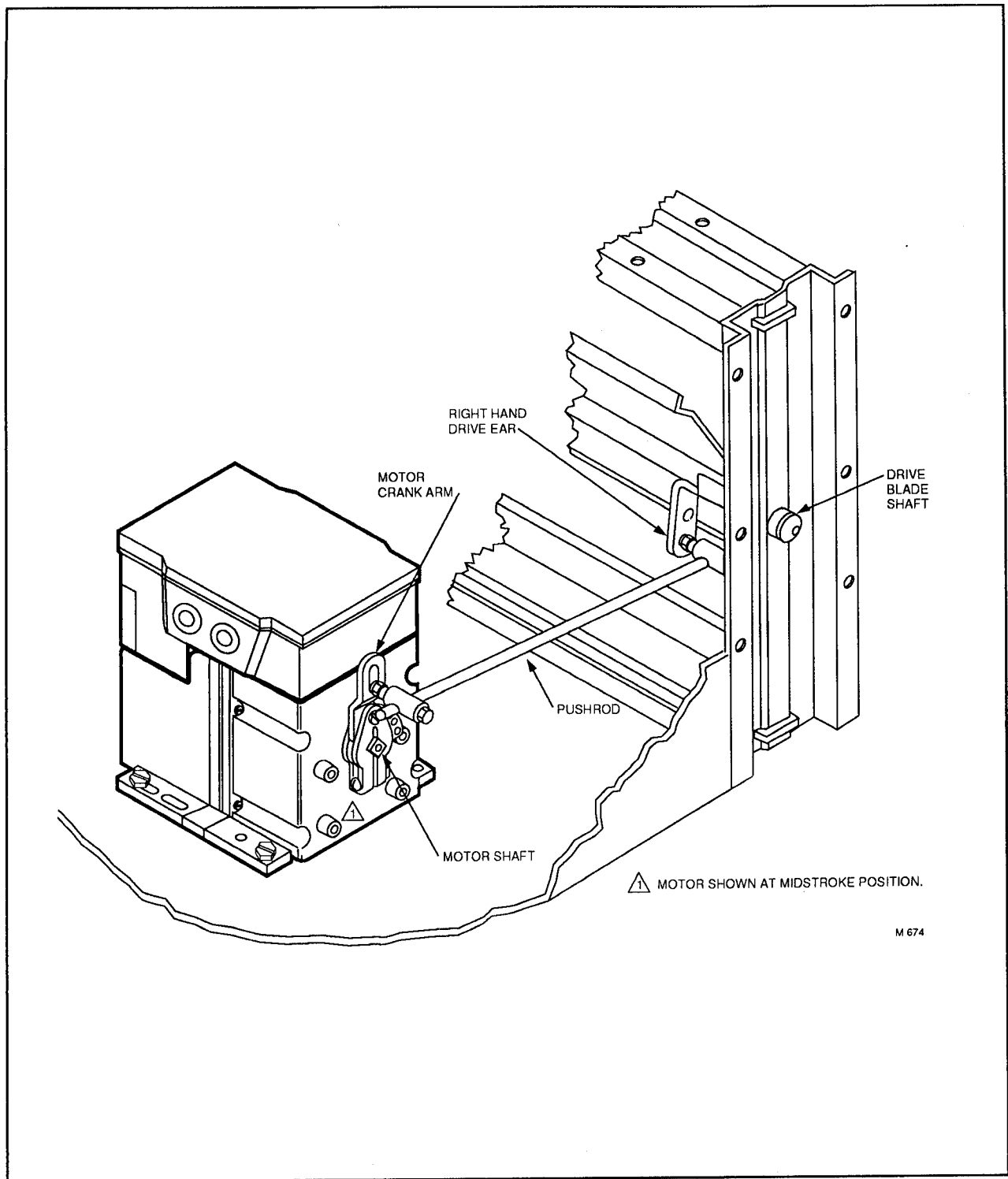

**FIG. 20—MODULATING OPERATION OF A NORMALLY CLOSED DAMPER. POSITION ADAPTER ARM SAME AS CRANK ARM ABOVE.**

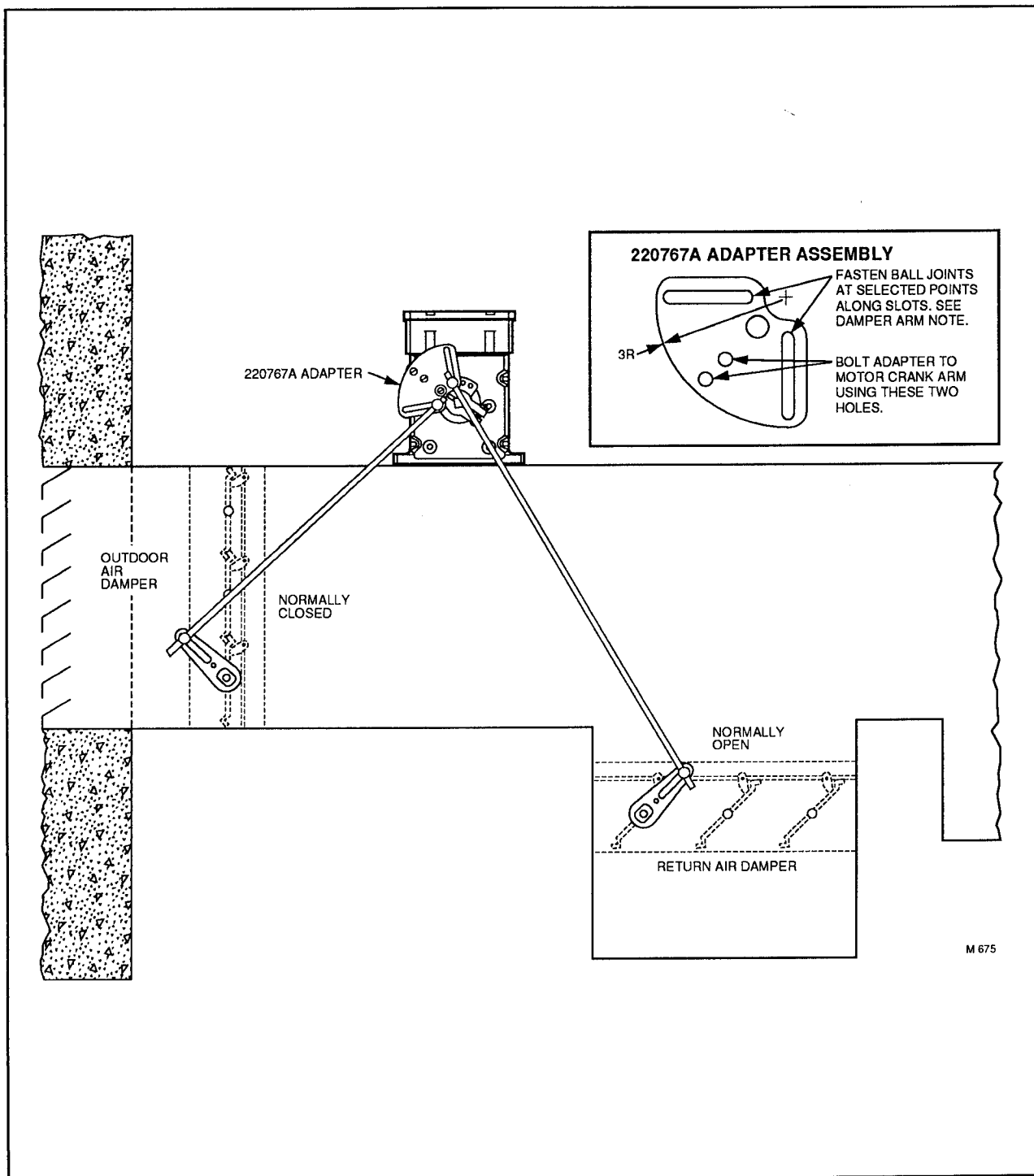

**FIG. 21—MOTOR MOUNTED EXTERNALLY ON THE DUCT TO CONTROL TWO DAMPERS ACTING AT RIGHT ANGLES. USE OF ADAPTER ASSEMBLY ELIMINATES ONE DAMPER ARM, AND ALSO MAKES POSSIBLE THE USE OF TWO PUSH RODS OF NEAR EQUAL LENGTH INSTEAD OF ONE SHORT ROD AND THE OTHER TOO LONG TO BE PRACTICAL.**

**Honeywell Inc.**  
 U.S.A.: 1885 Douglas Drive N.  
 Golden Valley, MN 55422-4386  
 CANADA: 740 Ellesmere Road  
 Scarborough, Ontario M1P 2V9

International Sales Offices in all principal cities of the world. Manufacturing in Australia, Canada, Finland, France, Germany, Japan, Mexico, Netherlands, Spain, Taiwan, United Kingdom, U.S.A.

PRINTED IN U.S.A.



QUALITY IS KEY