

M6410A, M7410F, M6435A, M7435F Actuators V5852A, V5853A, V5862A, V5863A Valves

40.5 LB (180N) NON-SPRING AND SPRING RETURN ACTUATORS
AND 1/2 INCH, 3/4 INCH CARTRIDGE GLOBE VALVES

PRODUCT DATA



FEATURES

- Small size allows installation in limited space.
- Long stroke allows wider range of control.

Actuators

- Low power consumption.
- Synchronous motor.
- No mounting tools required (including the MP958).
- Low-maintenance plastic housing.
- Conduit connector standard.
- No separate linkage required.
- M64XXA provides 3-position floating control without proportional feedback.
- M74XXF receives 0 to 10 Vdc or 2 to 10 Vdc input signal, selectable at the site.
- M74XXF includes direct/reverse acting switch.

Non-Spring Return (M6410A, M7410F)

- Especially suitable for Excel[®] Controller or Individual Room Controller (IRC) System.
- Internal valve position indicator.
- Magnetic coupling for torque limitation independent of voltage supply, and self-adjustment of close-off port.
- Ready-to-wire connecting cable.

Spring Return (M6435A, M7435F)

- Force-limiting end switches.
- No calibration.

Valves

- V5852A is a two-way female sweat valve.
- V5853A is a three-way female sweat mixing valve.
- V5862A is a two-way female NPT valve.
- V5863A is a three-way female NPT mixing valve.
- Soft valve seat provides low leakage rate.
- Valve inserts are changeable without draining valve when used with the insert replacement tool.
- Threaded plastic cover allows manual operation.
- Brass body and stainless steel stem.

APPLICATION

M6410A and M7410F Series 1000 Non-Spring Return Valve Actuators provide floating or modulating control of Series 1000 and 2000 V5852A, V5853A, V5862A and V5863A Cartridge Globe Valves.

M6435A and M7435F Series 1000 Spring Return Valve Actuators provide floating or modulating control of Series 1000 and 2000 V5852A, V5853A, V5862A and V5863A Cartridge Globe Valves.

The actuators are used in electronic temperature control systems, which use hot and/or cold water (with glycol up to 50 percent) as the controlled medium in variable air volume (VAV) terminal units, fan-coil units, small reheaters and recoolers.

The V5852A, V5853A, V5862A, V5863A Series 1000 and 2000 Cartridge Globe Valves can also be controlled by MP958A Pneumatic Valve Actuators.

SPECIFICATIONS

IMPORTANT

The specifications given in this publication do not include normal manufacturing tolerances. Therefore, an individual unit may not exactly match the listed specifications. Also, this product is tested and calibrated under closely controlled conditions and some minor differences in performance can be expected if those conditions are changed.

Models:

- M6410A: Non-Spring Return Valve Actuator. Provides floating control of the V5852A, V5853A, V5862A and V5863A Valves.
- M6435A: Spring Return Valve Actuator. Provides floating control of V5852A, V5853A, V5862A and V5863A Valves. Stem retracts upon power failure.
- M7410F: Non-Spring Return Valve Actuator. Provides modulating control of V5852A, V5853A, V5862A and V5863A Valves.
- M7435F: Spring Return Valve Actuator. Provides modulating control of V5852A, V5853A, V5862A and V5863A Valves. Stem retracts upon power failure.
- V5852A: Two-way Sweat Valves.
- V5853A: Three-way Sweat Mixing Valves.
- V5862A: Two-way NPT Valves.
- V5863A: Three-way NPT Mixing Valves.

CAUTION

Equipment Damage Hazard.
Installing a high-force (67.5 lb [300 N]) actuator on 1/2 or 3/4 in. valve can damage the valve beyond repair.

Use only Series 1000 (40.5 lb [180 N]) actuators with these smaller (1/2 in. and 3/4 in.) valves.

IMPORTANT

- Complete valve body soldering (V5852, V5853) before installing cartridge inserts.
- Install low-force actuators (40.5 lb) only on small valves (1/2 in., 3/4 in.).

Dimensions:

- Valves: See Fig. 1.
Spring Return Actuators: See Fig. 2.
Non-Spring Return Actuators: See Fig. 3.

Stroke: 1/4 in. (6.5 mm).

Control Modes:

M6410A, M6435A: Floating.
M7410F, M7435F: Modulating.

Electrical Ratings:

Input Power:
M6410A, M7410F: 24 Vac, +10/-30 percent, 50/60 Hz.
M6435A, M7435F: 24 Vac, +20/-15 percent, 50/60 Hz.

Power Consumption:
M6410A: 0.7 VA.
M7410F: 1.4 VA.
M6435A: 10 VA.
M7435F: 5 VA.

Input Signal (M7410F, M7435F): Modulating 0 to 10V, 2 to 10V (adjustable), 0.1 mA.
Input Impedance (M7410F, M7435F): 100K ohms.

Ambient Ratings:

Operating Temperature Range: 32° to 122°F (0° to 50°C).
Storage Temperature Range: -40° to 158°F (-40° to 70°C).
Humidity Range: 5 to 95% RH (noncondensing).

Mounting: Actuator screws onto valve body.

Connections:

M6410A, M7410F: 4.9 ft (1.5m) cable.
M6435A, M7435F: 1.5 sq mm terminals.

Weight:

M6410A: 5 oz (0.15 kg).
M7410F: 5.6 oz (0.16 kg).
M6435A, M7435F: 17.6 oz (0.5 kg).

Running Time:

At 50 Hz:
M6410A, M7410F: 150 seconds.
M6435A, M7435F: 60 seconds.

At 60 Hz:
M6410A, M7410F: 125 seconds.
M6435A, M7435F: 50 seconds.

Spring Return Time: 10 seconds.

Stem Force: 40.5 lb (180 N).

Suitable Medium: Water with maximum 50% glycol.

Controlled Water Temperature: 36° to 230°F (2° to 110°C).

Leakage Rate: <0.02% of Cv.

ORDERING INFORMATION

When purchasing replacement and modernization products from your TRADELINE® wholesaler or distributor, refer to the TRADELINE® Catalog or price sheets for complete ordering number.

If you have additional questions, need further information, or would like to comment on our products or services, please write or phone:

1. Your local Honeywell Automation and Control Products Sales Office (check white pages of your phone directory).
2. Honeywell Customer Care
1885 Douglas Drive North
Minneapolis, Minnesota 55422-4386

In Canada—Honeywell Limited/Honeywell Limitée, 35 Dynamic Drive, Scarborough, Ontario M1V 4Z9.

International Sales and Service Offices in all principal cities of the world. Manufacturing in Australia, Canada, Finland, France, Germany, Japan, Mexico, Netherlands, Spain, Taiwan, United Kingdom, U.S.A.

Actuator Required:

M6410A: Non-Spring Return Valve Actuator (3-position floating).
 M6435A: Spring Return Valve Actuator (3-position floating; stem retracts upon power failure).
 M7410F: 0 to 10 Vdc or 2 to 10 Vdc Electronic Actuator, or
 M7435F: Spring Return Valve Actuator (modulating control; stem retracts upon power failure).
 MP958: Pneumatic Valve Actuator.
 Valve inserts are provided as spare parts. See Table 2.

Rangeability:

Two-way Valve: 50:1.
 Three-way Valve: 50:1 for controlled port (A to AB).

Flow Characteristic:

V5853, V5863: A to AB: Equal Percentage.
 B to AB: Linear.
 V5852, V5862: Equal percentage.

Valve Cv Rating: See Table 1.

NOTE: To determine the capacity index (Cv) needed for your application, use the following formula: Cv = gallons per minute divided by the square root of the pressure drop across the valve when the valve is fully open.

Valve Close-off Rating: See Table 1.

Body Material:

Red Brass: 1/2 in., three-way.
 3/4 in., two- and three-way.
 Yellow Brass: 1/2 in., two-way.

Stem and Plug Assembly:

Stem: Stainless steel.
 Plug: Brass.

Table 1. Valve Close-off Ratings.

Pipe Size in in. (mm)	Cv ^a	Close-off Rating (psi)	
		Two-way	Three-way
1/2 (13)	0.19	232	—
	0.29	232	116
	0.47		
	0.74	232	36
	1.2	174	
3/4 (19)	1.9	174	34
	2.9	58	34 ^b or 15 ^c
	4.9		

^a The Cv for the bypass port (B) on all three-way valves is reduced by one Cv level. Example: A Port Cv = 0.47; B Port Cv = 0.29. This feature eliminates the need for a balancing valve with the load matched to the proper Cv.

^b For V5853A1XXX and V5863A1XXX Valves (Series 1000).

^c For V5853A2XXX and V5863A2XXX Valves (Series 2000).

IMPORTANT

Mount all valve types in return flow. When delta p-values exceed 8.70 psi (60 kPa), noise can develop.

Approvals (Actuators): Underwriters Laboratories Inc. listed for plenum use (UL94-5V).

Accessories and Replacement Parts:

WV108B Brush Tool for valve seat cleaning (used with WV108 tool).

WV108M Insert Replacement Tool, for replacing cartridge insert without draining system.

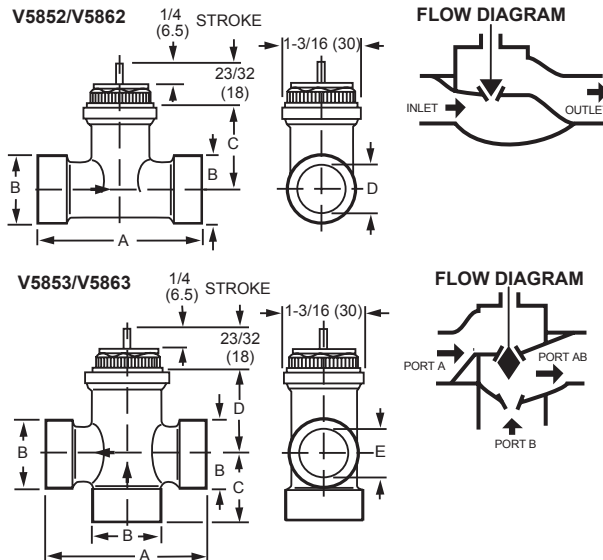

VALVE SIZE	A	B	C	D (NPT)	D (SWEAT)
1/2 (13)	3 (77)	3/4 (19)	1-5/16 (34)	1/2 (13)	5/8 (16)
3/4 (19)	3-1/2 (88)	1 (25)	1-1/4 (32)	3/4 (19)	7/8 (22)

VALVE SIZE	A	B	C	D	E (NPT)	E (SWEAT)
1/2 (13)	3 (77)	3/4 (19)	1-5/16 (34)	1-5/16 (34)	1/2 (13)	5/8 (16)
3/4 (19)	3-1/2 (88)	1 (25)	1-1/2 (38)	1-1/4 (32)	3/4 (19)	7/8 (22)

NOTE: SOLDER ENDS CONFORM TO ANSI B16-18.

M7559A

Fig. 1. Dimensions of V5852A, V5853A, V5862A and V5863A in in. (mm).

Table 2. Valve Insert Replacement Parts.

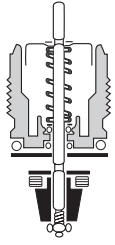
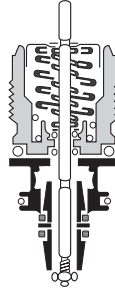
Diameter (in.)	For Valve	Cv	Part Number	Interchangeable With	
Two-Way					
1/2	V5852A2007, V5862A2005	0.19	0902812	0902809, 0902810, 0902811	
	V5852A2015, V5862A2013	0.29	0902811	0902809, 0902810, 0902812	
	V5852A2023, V5862A2021	0.47	0902810	0902809, 0902811, 0902812	
	V5852A2031, V5862A2039	0.74	0902809	0902810, 0902811, 0902812	
	V5852A2049, V5862A2047	1.20	0902808	0902807	
	V5852A2056, V5862A2054	1.90	0902807	0902808	
3/4	V5852A2064, V5862A2062	2.90	0902814	0902815	
	V5852A2072, V5862A2070	4.90	0902815	0902814	
Three-Way					
1/2	V5853A2006, V5863A2004	0.29	0902821	0902822, 0902823, 0902824	
	V5853A2014, V5863A2012	0.47	0902822	0902821, 0902823, 0902824	
	V5853A2022, V5863A2020	0.74	0902823	0902821, 0902822, 0902823	
	V5853A2030, V5863A2038	1.20	0902824	0902821, 0902822, 0902824	
	V5853A2048, V5863A2046	1.90	0902825	None	
3/4	V5853A2055, V5853A1008, V5863A1006, V5863A2053	2.90	0902827	None	
	V5853A2063, V5853A1016, V5863A1014, V5863A2061	4.90	0902827	None	

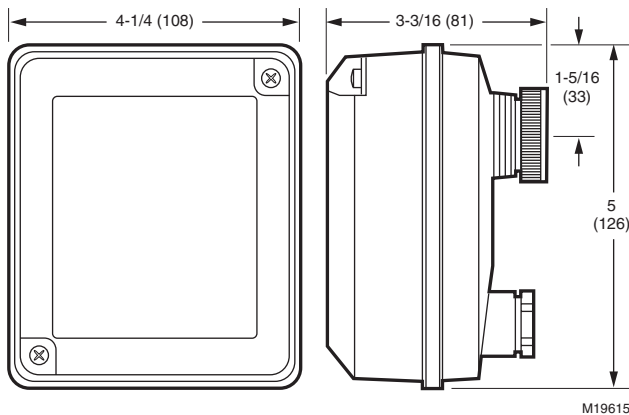

Fig. 2. Spring Return Actuator (M6435, M7435) dimensions in in. (mm).

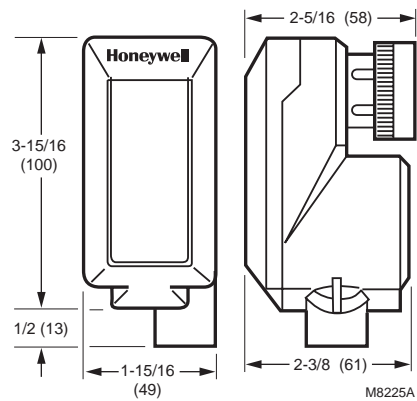

Fig. 3. Non-Spring Return Actuator (M6410, M7410) dimensions in in. (mm).

INSTALLATION

When Installing this Product...

1. Read these instructions carefully. Failure to follow them could damage the product or cause a hazardous condition.
2. Check ratings given in instructions and on the product to ensure the product is suitable for your application.
3. Installer must be a trained, experienced service technician.
4. After installation is complete, check out product operation as provided in these instructions.

WARNING

Severe Scalding Hazard.

Contact with hot liquid can lead to severe injury or cause death.

For a pressurized valve, only open with Valve Cartridge Replacement Tool. For complete safety, release system pressure to the valve body before changing cartridge.

! CAUTION

Electrical Shock or Equipment Damage Hazard.
Can shock individuals or short equipment circuitry.

Disconnect power supply before installation.

! CAUTION

Sweat Valve Damage Hazard.
Soldering the valve with the cartridge in place can damage the device.

Prior to attaching valve to piping, remove cartridge from potential exposure to heat.

IMPORTANT

- Before installing the valve and actuator, use the protective cover/manual handle to ensure the valve stem operates freely. Impaired stem operation can indicate a bent stem (due to rough handling). This condition can require replacing the valve.
- When installing valves, make sure the flow direction is correct by checking the arrow on the valve body.
- Mount the valve only with the stem pointing upward.
- Leave the protective cover in place until ready to attach the actuator.

Location

Select a location where the valve and actuator are accessible.

IMPORTANT

Mount all valve types in return flow. When delta p -values exceed 8.70 psi (60 kPa), noise can develop.

Mounting

Valve

The valve body should be completely installed in the pipe line before the actuator is installed.

IMPORTANT

The insert is packed separately from the V5852, V5853 Sweat Valve. The valve must be installed and soldered before the insert is installed in the valve. Torque the insert between 27 and 44 in.-lb.

1. Verify pipe size and flow direction for the valve being used.
2. Position the valve so that the actuator can be easily installed.
3. Install the valve using the applicable tools and supplies (wrenches, solder, flux, torch or soldering iron). Follow standard practices.

Actuator

No tools are required to install the M6410A or M7410F on a valve because they are threaded onto the valve by hand. Do not overtighten by using a wrench on the connection, because this can damage the valve or actuator.

To mount the M6410A or M7410F Actuator, refer to Fig. 4 through 6. Fig. 5 shows the valve position indicator.

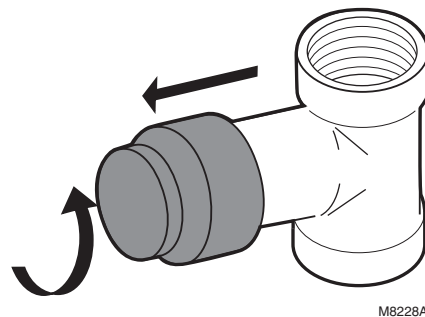

M8228A

Fig. 4. Removing protective cover from valve.

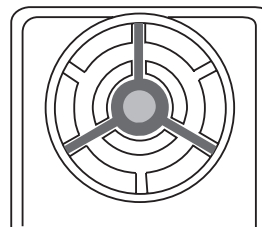

M8227A

Fig. 5. Valve position indicator (M6410 shown).

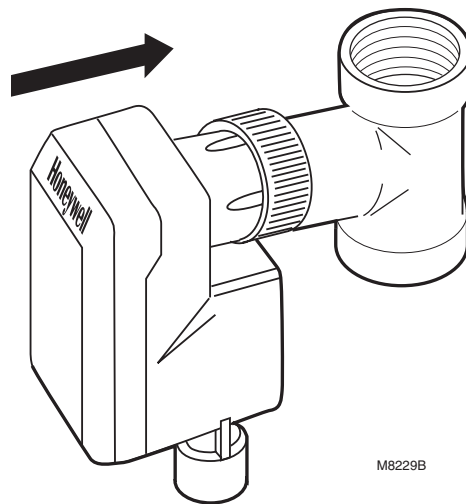

M8229B

Fig. 6. Mounting actuator to valve (M6410 shown).

1. Remove the protective cover from the valve (Fig. 4).
2. Make sure the actuator is in the (factory-supplied) OPEN position.
3. Screw the actuator connector onto the body of the valve (Fig. 6).

Wiring

Connect the M6410A, M6435A Actuators to the controller using the controller wiring diagram. See Fig. 8 for a typical T6984F hookup. For Excel 10[®] hookup see Fig. 11.

Use the M7410F, M7435F with Excel® 5000/500/100/80 or T7984 Controllers. Power the M7410F from the same transformer as the controller. See Fig. 9 and 10. Electrical installation must comply with wiring diagram shown in Fig. 7.

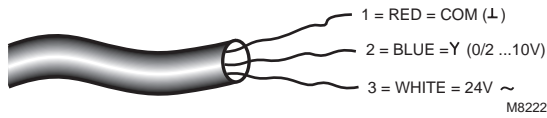

Fig. 7. Electrical installation showing wire colors and definitions.

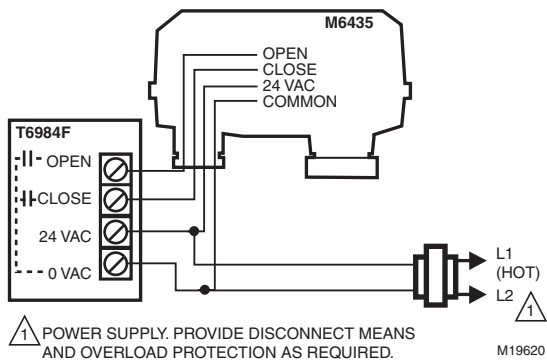

Fig. 8. M6435A used with T6984F.

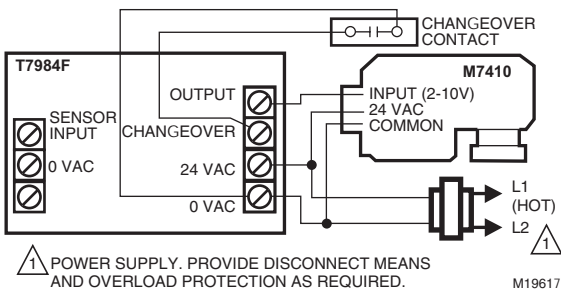

Fig. 9. M7410F used with T7984F.

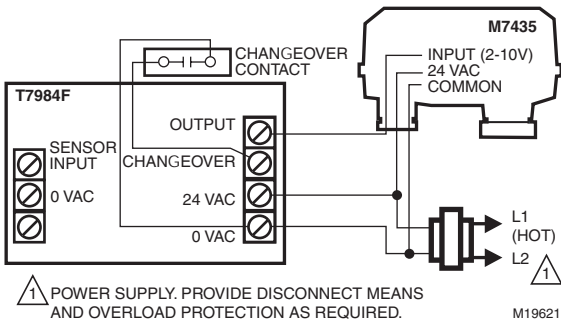

Fig. 10. M7435F used with T7984F.

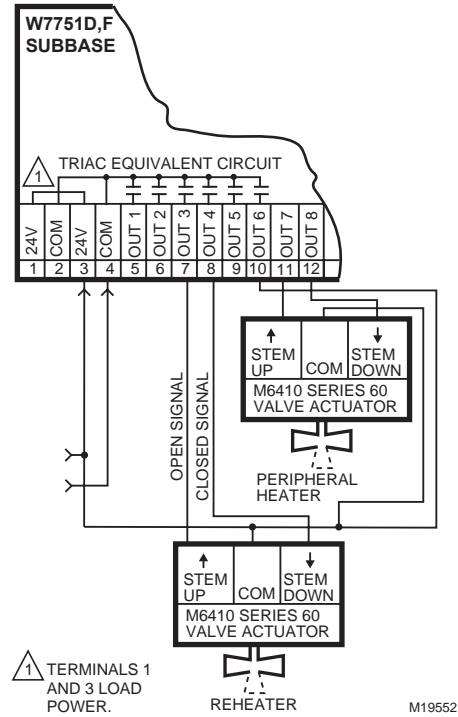

Fig. 11. M6410A Actuator wired with W7751D,F Controller.

Switch Selection (M7410F)

The two built-in selector switches must be set according to the valve type (two-way or three-way) and the controller output signal (0 to 10V or 2 to 10V). See Fig. 12.

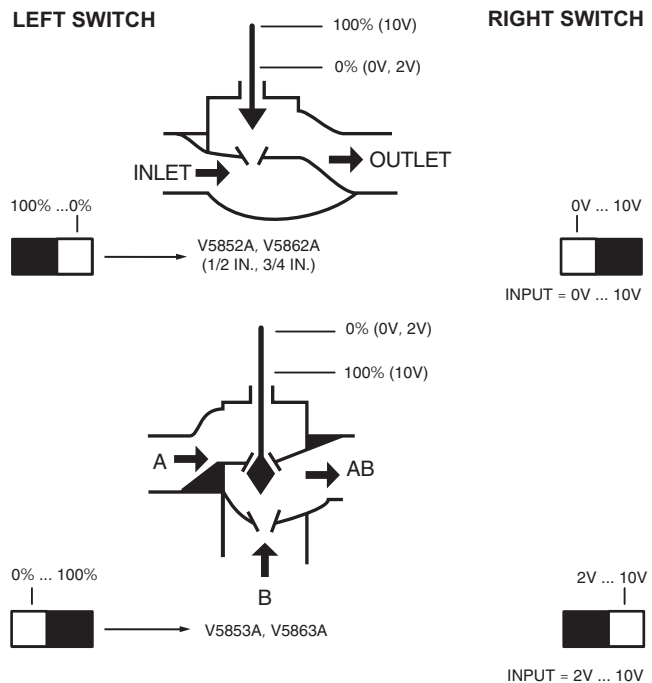

Fig. 12. Switch selection according to controller output signal and valve type (two-way or three-way).

Switch Selection (M7435F)

The two built-in selector switches must be set according to the desired valve action and the controller output signal (0 to 10V or 2 to 10V). See Fig. 13.

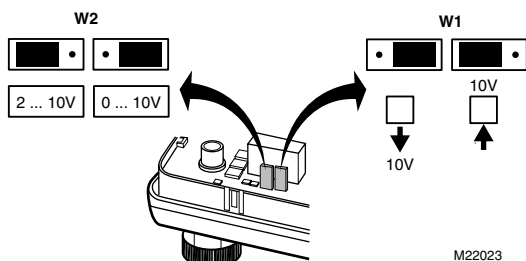

Fig. 13. Switch selection according to controller output signal and valve type (two-way or three-way).

Input Signal Override (M7410F)

To override the controller output signal, connect the input signal wire with COM (0%) or 24V (100%), see Fig. 14, using an external relay.

If the temperature falls below a certain point; for example, 32°F (0°C), a relay can switch the 24 Vac to the Y connection (0 to 10V, 2 to 10V). This opens or closes the valve.

OPERATION

Apply power to the actuator to drive the synchronous motor to turn a screw spindle that opens or closes the valve. The actuator is attached to the valve by a hand-tightened coupling ring and a magnetic coupling that limit the gear assembly torque and the actuator driving force.

The actuator pushes the center stem of the valve down, compressing the valve spring and closing the valve. When the actuator reverses, the valve spring expands, opening the valve and pushing the center stem up.

The valves are supplied with a threaded plastic protective cover/manual handle to protect the stem and to allow for manual operation. Use the protective cover/manual handle to fill the system during initial installation.

Turning the protective cover/manual handle:

- Clockwise: pushes the center stem of the valve down, compressing the valve spring and closing the valve.
- Counterclockwise: allows the spring to expand, pushing the center stem up and opening the valve.

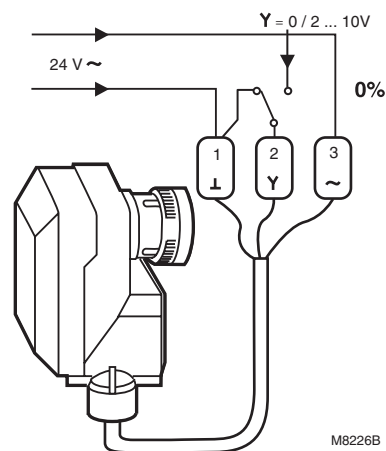
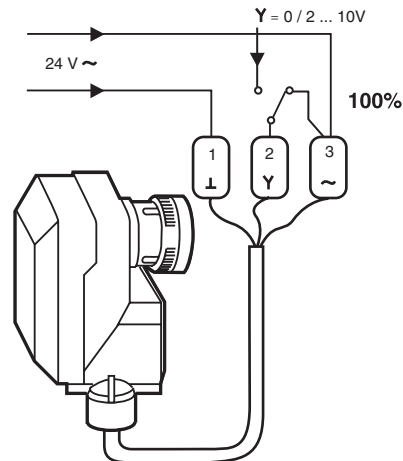

Fig. 14. Input signal override for frost protection.

NOTES:

- You can also use the protective cover/handle for heating/cooling with neither a controller nor actuator during the building construction phase.
- Retain the protective cover. It can be needed for future manual operation.

Commissioning

A microprocessor within the actuator maintains accurate control/positioning by recommissioning itself every 24 hours or whenever power is applied or interrupted. When power is applied, the actuator drives to 0 and then to its starting position according to the starting/input signal. The initial commissioning or 24-hour recommissioning takes between 2.5 and 5 minutes, depending on the position of the actuator.

Valve Flow

TWO-WAY VALVES

In the two-way valves, the direction of flow is always from inlet port to outlet port as indicated by the arrows on the valve body (see Fig. 15).

THREE-WAY VALVES

Three-way valves are designed to be used as mixing valves. This means that port AB is the total flow outlet; port A is the controlled flow inlet; and port B is the bypass inlet (see Fig. 16).

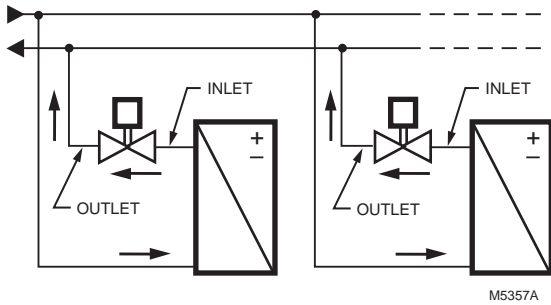

Fig. 15. Two-way valve operation block diagram.

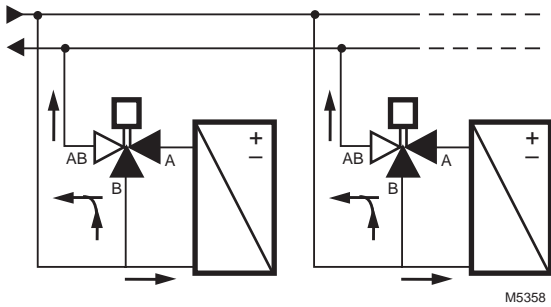

Fig. 16. Three-way valve operation block diagram.

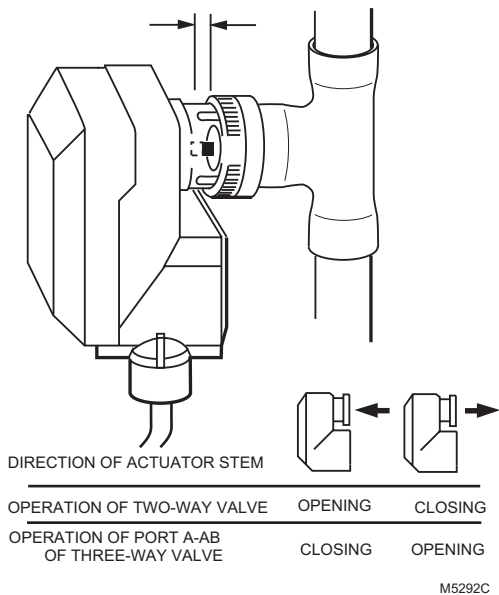

Fig. 17. Direction of actuator stem during operation (M6410 shown).

CHECKOUT

IMPORTANT

Operating the system through one complete cycle is recommended to verify that the valve and actuator function properly.

Valve

Check Body and Connections for Leaks

Before installing actuator, make sure that the valve stem operates freely by using the protective cover/manual handle. Impaired stem operation can indicate that the body was twisted by faulty piping or that the stem was bent by rough handling. Either of these conditions can require replacement of the valve or cartridge insert.

If leaking or other problems occur:

1. Remove pressure from the valve.
2. Remove the cartridge insert.

NOTE: Instructions for removing and replacing the cartridge insert are packed with the WV108 Insert Replacement Tool.

3. Make sure the cartridge insert O-ring is properly seated and not damaged.
4. After installing the actuator, check actuator operation.

Actuator

Perform a functional checkout of the M6410A Actuator as follows:

1. Change the room temperature setpoint by at least 10°F (6°C).
2. Make sure the actuator either opens or closes the valve, depending on the direction of the temperature change. See Fig. 17.
3. If the actuator stem moves in the wrong direction, reverse the connections for the open and close actuator wires.
4. If step 3 does not resolve the problem, replace the actuator.

Perform a functional checkout of the M7410F Actuator as follows:

1. Change the Y input signal. The movement of the actuator stem (Fig. 17) indicates if the valve is opening or closing.
2. If the direction of the valve stem travel is not correct, reset the direct/reverse switch.

Honeywell

Automation and Control Solutions

Honeywell International Inc.
1985 Douglas Drive North
Golden Valley, MN 55422

Honeywell Limited-Honeywell Limitée
35 Dynamic Drive
Scarborough, Ontario
M1V 4Z9

Honeywell International

Control Products
Honeywell Building
17 Changi Business Park Central 1
Singapore 486073

Honeywell Europe S.A.

3 Avenue du Bourget
1140 Brussels
Belgium

Honeywell Latin American Region

480 Sawgrass Corporate Parkway
Suite 200
Sunrise FL 33325

