

# How to assemble the Allegro® Reformer

## PARTS LIST

Part number	Description	Qty
950-002	Complete footbar	1
950-020	Pivot bolts and washers	1 kit
950-228	Shoulder rest with brackets	1 pair
616-400	Locking shoulder post	2
GEN8000	Twist lock plunger knobs	2
210-070	Soft Touch Ropes	1 pair
210-064	Double loops (Soft Touch)	1 pair
950-225	Allegro riser with pulley	2
GEN9050	5/16" Allen wrench	1
ALL0060	Allegro wrench	1
SPR9070	Red spring	3
SPR9071	Blue spring	1
SPR9241	Yellow spring	1
DVD8413	Introductory DVD	1

### IMPORTANT PRECAUTIONS: PLEASE READ WARNING

**To reduce the risk of serious injury, read the following important precautions before using the Allegro.**

- » Read all instructions in this manual before using the Allegro. Review the Setup and Safety video included with the Allegro before using the equipment. Use the Allegro only as described in these instructions and the video.
- » It is the responsibility of the owner to ensure that all users of the Allegro are adequately informed of all precautions.
- » Use the Allegro only on a level surface. Keep hands and feet away from all moving parts. When the Allegro is not in use, leave at least two springs connected to the carriage. Keep children under the age of 12 and pets away from the Allegro at all times.
- » If you feel pain, dizziness, or shortness of breath, stop exercising immediately.
- » Before beginning any exercise program, consult your physician.



## INSTALL THE SHOULDER RESTS

1. Note the two protruding studs on the bottom of the shoulder rests. Lower the shoulder rest studs into the keyholes and slide away from the carriage pad. See Figure A.

**Note:** The shoulder rests can be installed in two positions. One position is wider, and more comfortable for broad shoulders. Swap the left and right shoulder rests to change between standard and wide configurations.

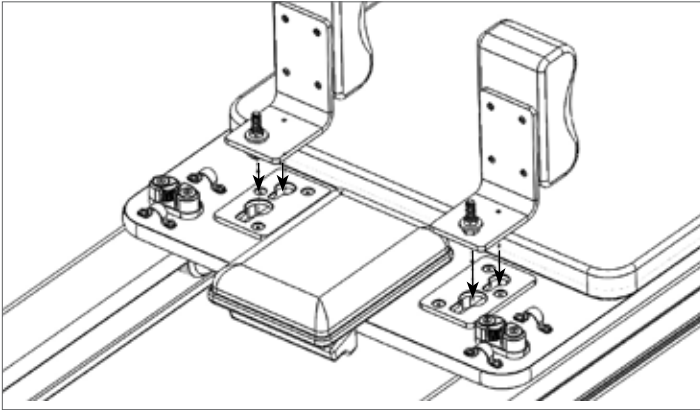

Figure A

2. Now screw the locking shoulder posts onto the exposed bolt on each shoulder rest. See Figure B.

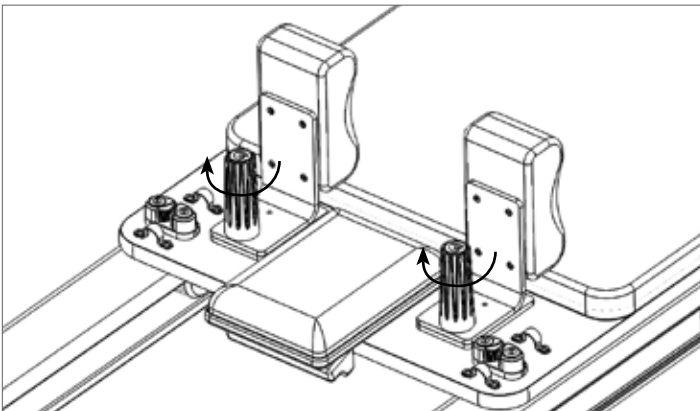

Figure B

### Using the Locking Shoulder Posts:

Turn the posts clockwise to tighten them and lock the shoulder rests into position. Over tightening the posts will make them difficult to remove, they should be snug but not too tight. To remove the shoulder rests, turn the post counter clockwise 1-2 turns and gently slide the shoulder rests toward the carriage.

Figure C shows the storage position for the shoulder rests. Note the key hole slots at the head end of the Allegro frame.

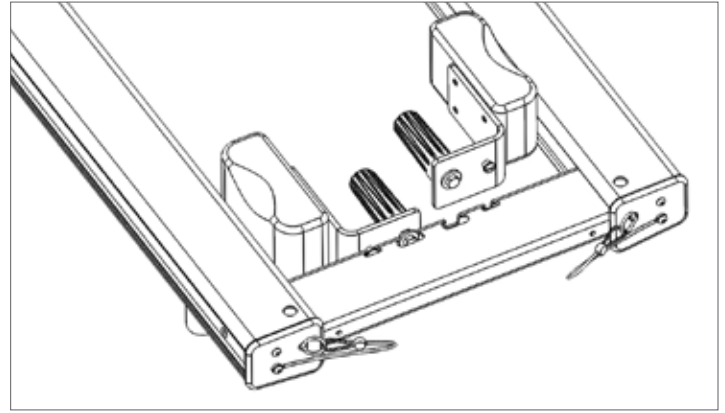

Figure C

## INSTALL THE BLACK PLUNGER KNOBS

3. Look through the large threaded hole in the trunnion and line it up with one of the holes in the frame. Screw the plunger knob into the large hole until it is completely threaded in. See Figure D.

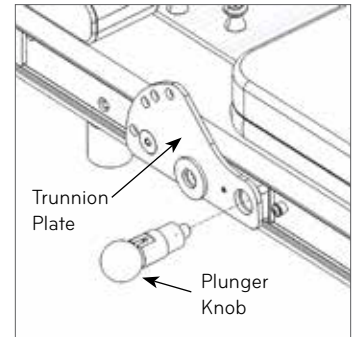

Figure D

4. Repeat on other side. Tighten both plunger knobs securely with the included open end wrench.

To move the trunnions, pull the ball of the plunger knobs away from the frame and turn 90° to lock out. To re-engage the plunger turn the knob until it snaps into one of the holes in the side of frame.

**Note:** Make sure both trunnion plates are locked in the same horizontal position before moving on.

## INSTALL THE FOOTBAR

5. Pick up the footbar so the seam of the footbar cover is away from the carriage pad.
6. While squeezing the footbar plunger levers, guide the footbar over the outsides of the trunnion plates. Align each footbar pin with the top hole in the trunnion plate.

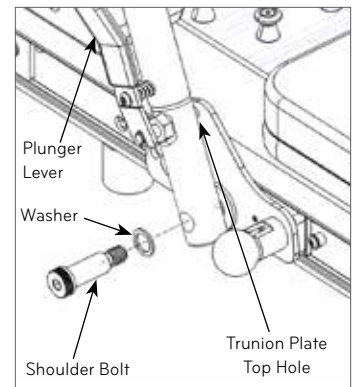

Figure E

While continuing to support the footbar, release the footbar plunger levers to engage the trunnion plate. Be sure the pins on both sides are engaged. See Figure E.

- Pivot the footbar slightly until the large hole at the bottom of the footbar aligns with the remaining hole in the trunnion plate.
- Slide the shoulder bolt with one washer through the large footbar hole. Then screw the shoulder bolt into the trunnion plate as tightly as possible with the large allen wrench. Repeat on the other side. See Figure E.

#### INSTALL THE RISERS

- Remove locking pins from the frame. Insert the risers through the holes on the top of the frame. Turn the risers until the attached pulleys point straight down the frame toward the footbar. See Figure F.
- Reinsert locking pins until the metal ring touches the frame. You may need to jiggle or slightly lift or rotate the riser to get the locking pins in all the way.

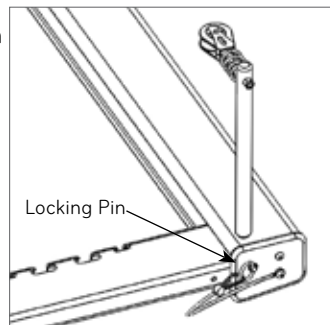

Figure F

#### ATTACH THE ROPES

- To attach the ropes, first engage at least one spring from the carriage to the frame to keep the carriage in the home position. Unroll the ropes and separate them.
- The Allegro now comes with Soft Touch Ropes that do not have the dog-clips to attach the loops. The clip will no longer drag on or bang into the frame! Follow the images below to install your loops. See Figure G.

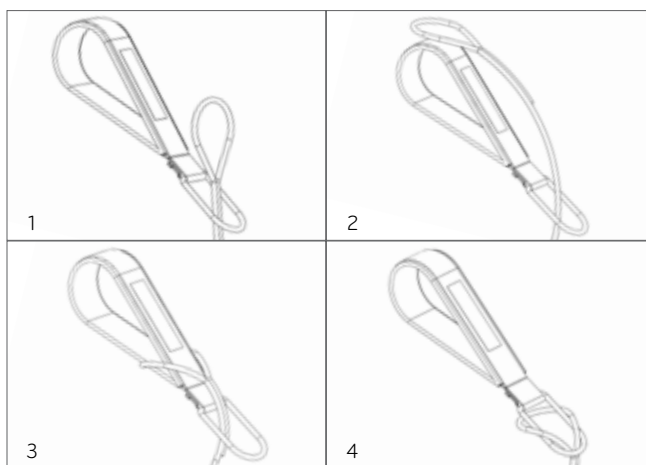

Figure G

- Rest the loops over the shoulder rests. Thread the other end of each rope through a riser pulley and back into the cam cleats on the carriage to adjust the length. Be sure to go through the chrome eyestraps on both sides of the cam cleats. Always push the rope firmly down into the cleats to ensure a good grip.

#### STORING THE ALLEGRO REFORMER

##### Stacking

To see a demonstration of how to stack the Allegro, watch the Setup and Safety portion of the Allegro Introductory/Level 1 DVD. Attach the springs to keep the carriage from moving. Move the footbar to the "down" position. Remove the shoulder rests and store in the slots at the head of the frame. Put the head rest down. Remove the risers and store in the holes on the sides of the frame. Place the ropes and loops inside the Allegro frame not on the carriage. Alternate the orientation of the Allegros as you stack them. Place the head end feet onto the standing platform of the Allegro below, and so on. Stack a maximum of 5 reformers with no legs (3 with legs). Do not stack Reformer with Towers.

##### Standing

It is absolutely critical that the Allegro footbar be set and locked in the correct position for standing storage. Move and lock the footbar into the position closest to the foot-end of the Reformer frame. Raise the footbar to its highest position. Lift the head-end of the Allegro frame to waist height. Then raise the frame to vertical. Use your foot to steady the wheeled end of the frame as you lift to vertical. The vertical Allegro will come to rest on the footbar and the transport wheels. See Figure H.



Figure H

#### CLEANING & MAINTENANCE

##### Cleaning

Wipe the carriage pad, headrest, footbar and shoulder rests with a soft cloth and a mild, non-abrasive cleaner after each use. Keep the carriage track and wheels clean from dust and dirt. Wipe the entire track with a towel regularly. Clean the footbar trunnion track weekly. Clean the frame with a mild, non-abrasive cleaner. Keep the ropes and springs clear of dust. Cotton loops can be machine-washed. Hang to dry.

##### Lubrication

The foot bar trunnion C-channel can be lubricated with dry silicone spray.

#### MAINTENANCE

» See the included Safety First Guide.

#### QUESTIONS?

Call Balanced Body technical support at 1-800-745-2838 (US and Canada), or +1-916-388-2838.