

# Assembling the Balanced Body® CenterLine® Reformer

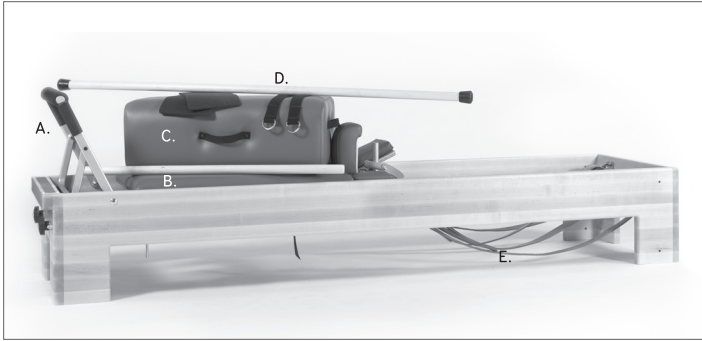

A. Footbar B. Carriage C. Sitting Box D. Gondola Pole & Dowel E. Straps

DESCRIPTION	PART NO.	QTY.
Gondola Pole	607-197	1
Short Box Dowel	607-128	1
Kneeling Pads	108-018	2
Sitting box	721-010	1
Cotton Foot Strap	607-349	1
Extender Straps	607-343	2
Leather Straps	607-482	2
Handles	950-161	1 pair
Green Springs	SPR9360	4
No Roll Springbar	607-323	1
Detachable Shoulder Assembly	N/A	2
Detent Pin w/Lanyard	N/A	2
Screw with locking knob	N/A	2
Carriage Extension Stopper	200-211	2

## INSTALL THE CARRIAGE

Clean all the carriage wheels and the metal rail surfaces of the frame. Carefully place the carriage into the frame with the headrest facing away from the footbar.

## INSTALL THE STRAPS

Place strap handles over shoulder rests. Insert the end of leather strap with the black fabric through the caster (rough leather side is against the caster) as shown in Figure A.

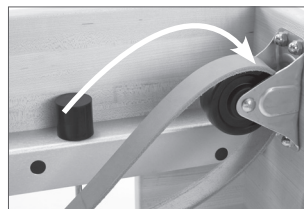

Figure A: Straps and Carriage Extension Stopper.

Guide the strap through the silver loop under the carriage as shown in figure B. Depress the metal lever on the clip and guide the black end of the strap through. It is important that the black strap goes through the clip as shown in Figure C. Adjust until strap is tight.

Note: straps would need to be adjusted if the springbar is moved to a different gear.

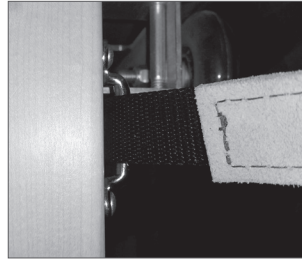

Figure B

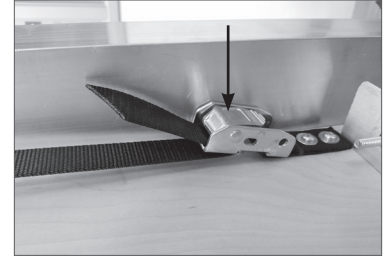

Figure C: Metal clips for attaching straps to under carriage.

## ATTACH THE SPRINGS TO THE UNDERSIDE OF THE CARRIAGE

Attach one spring to each eye-bolt on the underside of the carriage as shown in Figure D. The open end of the spring hook should be facing down.



Figure D: Springs at rest

## INSTALL THE SPRINGBAR

Place the springbar with hooks facing up into the gear block as shown in Figure E.

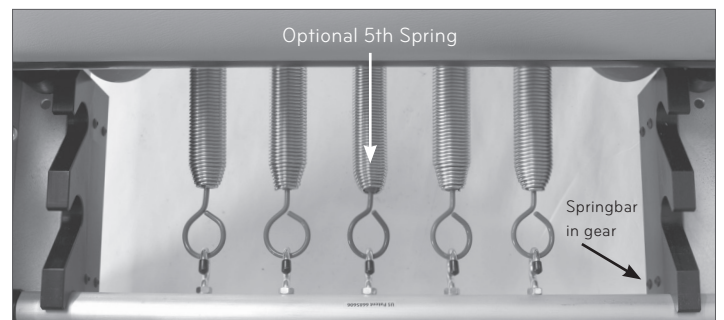

Figure E: Springs and Springbar.

## INSTALLING THE SHOULDER RESTS ON THE CENTERLINE™ REFORMER

Slide the shoulder rests into the shoulder lock plate on the carriage. There are two options to fix the shoulder rests.

1. Use the detent pin with lanyard for fast and easy removal. Unscrew the silver screw next to the headrest and guide the lanyard through it. Screw back into place. Use the detent pin to lock the shoulder rests.



Figure F

2. Use screw with the locking knob. Guide the screw through the hole in the shoulder bracket and the shoulder bracket lock. Use the locking knob to lock it from under the carriage.

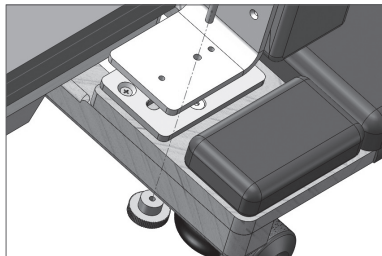

Figure G

## CARRIAGE EXTENSION STOPPER

Carriage stoppers are installed in the right hand carriage rail (if you are sitting on the carriage) to limit the distance the carriage can travel.

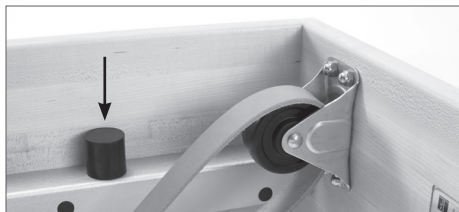

Figure H: Straps and Carriage Extension Stopper.

See Figure H.

This range limiter is most commonly used for clients who have a limited range of motion, or to stop the carriage from traveling too far. The CenterLine also features carriage stopper positions at the footbar end of the frame, used to change the carriage starting position and spring resistance.

## INSTALL THE OPTIONAL FOOT PLATE

Correct installation of the foot plate is very important. Properly installed, all BB foot plates should be vertical and fully supported by the footbar.



Figure I: Footbar and Footplate.

Loosen the two black knobs located at the footbar end of the frame. Place the footbar support into the slot in the gear block as shown in Figure I. Slide the padded foot plate into the bracket on the inside of the frame. Tighten the two black knobs to secure the foot plate into position. The Footbar will support the foot plate as shown (Fig. J)



Figure J: Proper Footbar Position.

## CLEANING AND MAINTENANCE

### Cleaning

You can extend the life of upholstery by keeping it clean and free of dirt, oil and perspiration. After each use, wipe down all skin-contact parts after each use, including carriage, shoulder and head rests.

Equipment upholstery is coated with BeautyGard®, which offers antibacterial protection. If you want additional disinfection, Balanced Body offers Balanced Body Clean™ disinfecting solution. Use of any other solution (especially those containing essential oils) will shorten the life of some equipment and is not recommended. A mild soap and water solution may also be used. Be sure to dry thoroughly.

For heavier soiling please call Balanced Body Technical Support. Wheel tracks and wheels should be cleaned regularly with a cloth to ensure that tracks smoothly and quietly.

Wash foot strap regularly. Place in pillowcase, wash on gentle cycle, air dry.

Be sure to inspect springs regularly.

If you have any questions on cleaning or maintenance, please call Balanced Body Technical Support.

### Lubrication and adjustment

As needed, lubricate casters with silicone spray. Be careful of overspray. Never use "wet" lubricants like WD40 or oil. Do not for any reason lubricate the carriage wheels.

### In case of freight damage

If there is freight damage, make certain you keep all packaging material. Please call Balanced Body immediately.

### QUESTIONS?

Please call Balanced Body Technical Support at 1-800-PILATES (U.S.) or +1-916-388-2838 (International).