

Allegro® Reformer Footbar Plunger Upgrade Kit

This kit updates your footbar plunger assembly to a new and improved design.

PARTS LIST (INCLUDED)

A.	ALL0038	Plunger Handle	2
B.	SPR9357	Spring, 1.25" long, zinc	2
C.	SPR9356	Spring, .46 OD	2
D.	GEN9282	Allen Key, 5/32"	1
E.	ALL0200	Plunger Nut	2
F.	GEN8306	Button Head Screw, 1/4-28 x 2	2
G.	ALL0201	Plunger Pin	2
H.	GEN9305	Washer	2

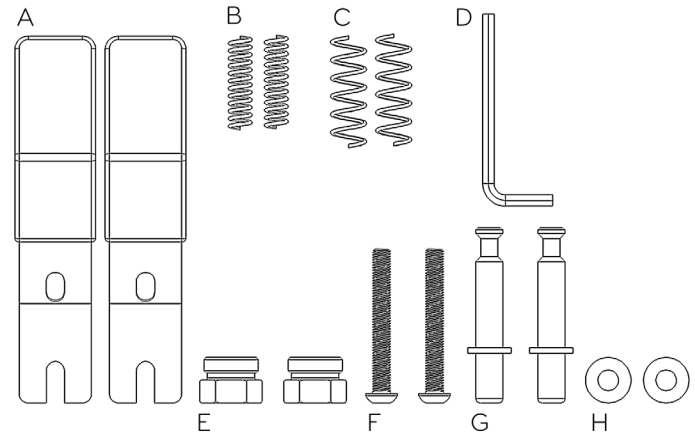

TOOLS NEEDED (NOT INCLUDED)

* 3/4" deep socket

1. Loosen the handle screw with the 5/32" allen wrench. Remove and discard the handle, screw, and spring. (Figure A)
2. Using a 3/4" deep socket, remove the plunger nut and the rest of the parts shown. Discard all old parts. (Figure A)
3. Remove the new parts from the bag and install them as shown in Figure B. Tighten the plunger nut.

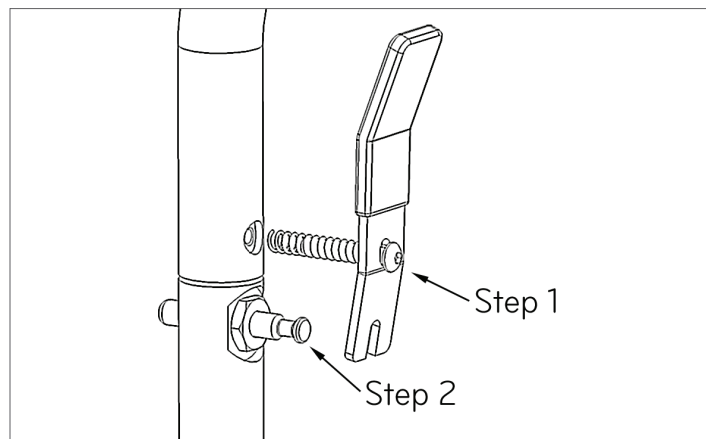

Fig. A

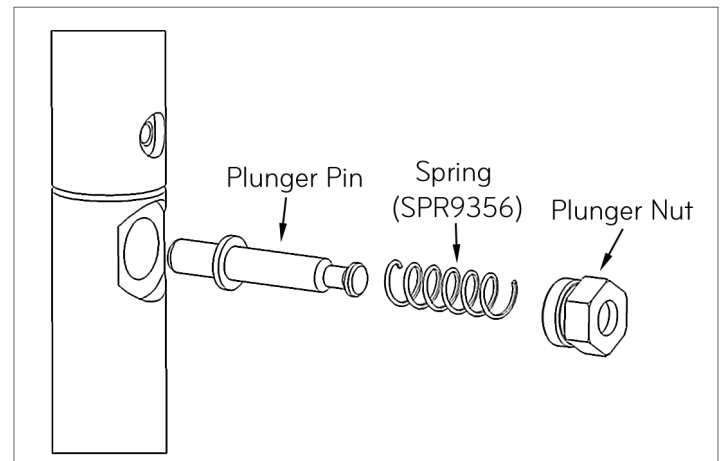

Fig. B

4. Insert the screw through the handle. Refer to Figure C to make sure it goes through the correct side of the handle (look at the bends in the handle). Slide a washer and then the smaller-diameter spring over the screw. Hook the handle onto the notch in the plunger pin (as shown). Now thread the screw into the footbar until it stops. Tighten it firmly. It will now look like Figure D.

Questions? Call Balanced Body® Technical Support at 1-800-PILATES (U.S and Canada) or +916-388-2838

5. Repeat on the handle on the other side of the footbar.

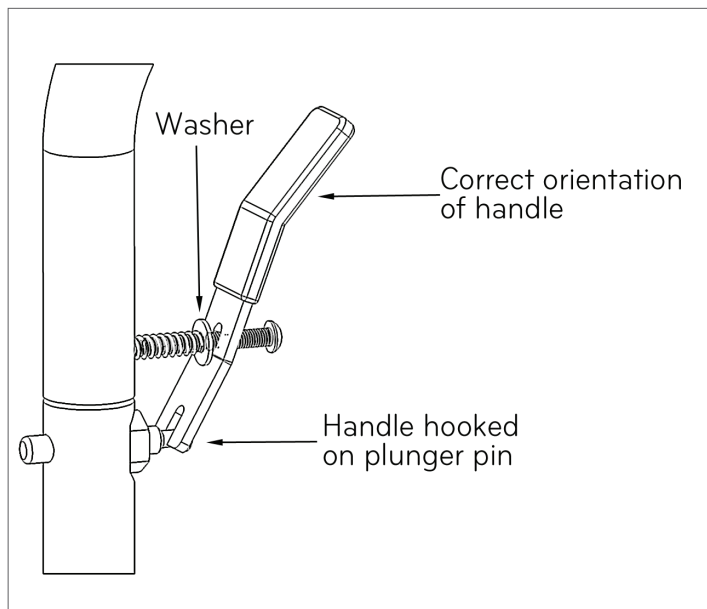

Fig. C

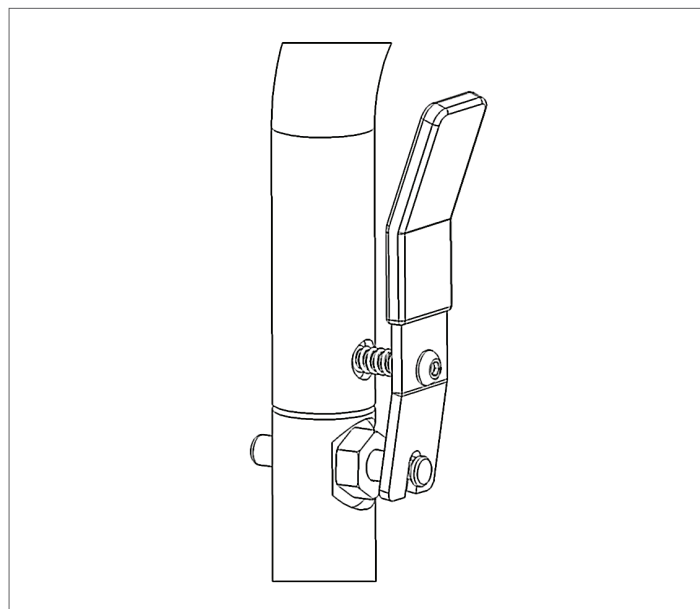

Fig. D