

## Constant Support

### Model R

#### Fig. 80-V: Standard

Type:  A,  B,  C,  D,  E,  F,  G

#### Fig. C-80-V: Corrosion Resistant

Type:  A,  B,  C,  D,  E,  F,  G

**Finish:** Standard finish; painted with semi gloss primer. Corrosion resistant; galvanized with coated coil or painted with CZII and coated coil.

**Recommended Service:** When piping stress is critical and pipe is subject to vertical movement in excess of 1/2" due to thermal expansion, and also at locations where it is necessary to avoid any transfer of stress from support or onto critical terminals or connecting equipment.

**Approvals:** WW-H-171E (Types 52, 58 and 59), ANSI/MSS SP-69 and MSS SP-58 (Types 54, 55 and 56).

**Features:**

- Because of exclusive geometric design, mathematically perfect constancy of support is maintained throughout the full range of load adjustment.
- Compactness – design provides smaller and more versatile units.
- Increased load and travel capacity.
- Each hanger is individually calibrated before shipment to support the exact load specified.
- All model R constant supports have a wide range of load adjustability. No less than 10% of this adjustability is provided either side of the calibrated load.
- White button marked "C" denotes cold setting of hanger; red button marked "H" denotes hot or operating setting.
- Field load adjustment is made by turning the single load adjustment bolt.
- Covered spring provides protection and good appearance.
- J-rod swings at least 4° from vertical.
- Non-resonant to all vertical vibrations.

**Size Range:** Anvil Model R constant support hangers are made in two basic designs, 80- V (vertical design) and 81-H (horizontal design). Combined, the 80-V and 81-H constant supports are made in nine different frame sizes and 110 spring sizes to accommodate travels from 1 1/2" to 20" and loads from 27 lbs to 87,500 lbs.

**Single rod suspension:** Available in Types A, B and C, Fig. 80-V and Fig. 81-H.

**How to select hanger sizes:** Determine the total load to be supported by the hanger as well as the actual travel – that is, the actual vertical movement of the pipe at the point of hanger location. Refer to the

Load-Travel table for constant support hangers in the Pipe Hanger Catalog and select a size hanger which will accommodate the known load and actual travel. It must be noted that the travel shown in the table is a total travel – that is, the maximum vertical movement which the hanger will accommodate. The total travel of the hanger should always be greater than the calculated travel of pipe line to allow for some discrepancy between calculated travel and actual travel.

**It is suggested that the total travel for constant supports should be equal to "actual travel" plus 1" or 20% whichever is greater.**

**How to determine type:** After the size of the constant support is determined, consideration of available room for suspending the pipe and hanger will indicate whether a vertical 80-V series or horizontal hanger is desirable.

**How to determine design:** After the hanger size and design are determined, the type of constant support to be used depends upon the physical installation required by the suspension problem, i.e., whether the hanger is to be installed above, between or below steel members (see line cuts referring to Types A, B, C, etc.). It will be noted that the Type F is made in horizontal design only and the type G is made in the vertical design only. **Special constant support hangers can be fabricated for unusual conditions.**

**J-rod and K-hole diameter:** Tapping or drilling for standard rod size will be furnished as shown in the J-rod and K-hole selection charts unless otherwise specified. Upper attachments, turnbuckles and clamps should be tapped to agree with the rod as shown in the selection chart. Standard rod diameters are based on the load to be carried by the upper rod which includes the weight of the hanger assembly as well as the pipe line. Tapped connections for hanger rod sizes 3" and smaller are UNC-Thread Series, Class 2 fit. 3 1/4" and large rod tappings are 8UN Series Threads.



Model R Fig. 80-V  
Vertical

PROJECT INFORMATION		APPROVAL STAMP
Project:		<input type="checkbox"/> Approved
Address:		<input type="checkbox"/> Approved as noted
Contractor:		<input type="checkbox"/> Not approved
Engineer:		Remarks:
Submittal Date:		
Notes 1:		
Notes 2:		

## Model R

(Continued)

### Ordering: Specify:

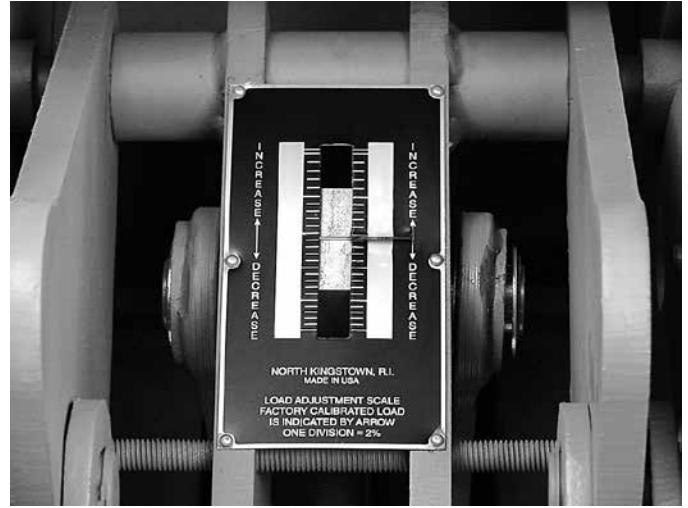
- (1) Hanger size number
- (2) Figure number
- (3) Type
- (4) Name of hanger
- (5) Loads to be supported (pounds)
- (6) Total travel (inches)
- (7) Actual travel (inches)
- (8) Direction of movement "cold to hot"
- (9) Customer's hanger mark.
- (10) When ordering Type G, specify C-C rod dimension as well as load per spring and total load.
- (11) For Types A, B, C, Fig. 81-H when required specify "for single rod suspension."
- (12) Constant Support Hangers are also available corrosion-resistant as figures C-80-V and C-81-H.

### Installation:

- (1) Securely attach the hanger to the building structure at a point where the load coupling is directly over the desired point of attachment to the pipe in the operating position.
- (2) Make certain that the moving parts of the hanger will be unobstructed.
- (3) Attach the lower J-rod between the pipe attachment and the load coupling. Make certain that the lower J-rod has enough thread engagement before taking up the load. A sight hole is provided for this.
- (4) Turn the load coupling, as you would a turnbuckle, until the travel indicator rotates to the desired cold setting (white button) marked "C" indicated on the position scale. If the constant support incorporates a travel stop see below.
- (5) After the line is in operation, check hanger for indicated hot setting. If necessary, make adjustment by turning the load coupling to bring the indicator to the hot position (red button) marked "H." No other adjustment is normally required since the load as calibrated at the factory is equal to the load specified to be supported.

**Adjustment:** When the hanger is installed, its supporting force should be in balance with the portion of the piping weight assigned to it. Each hanger is individually calibrated before shipment to support the exact load specified. All model "R" Constant Supports have a wide range of load adjustability. Special instructions for field recalibration of individual hangers may be obtained from Anvil representatives. No less than 10% adjustability is provided either side of the calibrated load for plus or minus field load adjustment. The percentage increase or decrease from the factory calibrated load should be carefully calculated. The calibrated load setting of each hanger is indicated by a die-stamp on the load adjustment scale. Load adjustments should be made from this reference point, with each division on the patented scale equal to 2% except sizes 84-110 where each division is valued at 1%. The load adjustment is made by turning the single load adjustment bolt. For example, a calibrated load of 3,000 pounds revised to 2,760 pounds is a decrease of 240 pounds.  $240/3,000 = 8\%$ . By turning the load adjusting bolt the arrow moves in the "Decrease" direction four divisions.

**Note:** Field Recalibration of load does not decrease total travel.



Load adjustment scale shown applies to size 1 through 83 only. The load adjustment scale for sizes 84 through 110 1 division equals 1%.

**Travel stop:** The functional design of the Constant Support Hanger permits the incorporation of a travel stop that will lock the hanger against upward or downward movement for temporary conditions of underload or overload, such as may exist during erection, hydrostatic test or chemical clean-out. Anvil Constant Supports are designed for hydrostatic test load of at least 2 times the normal operating load for the Constant Support. The travel stop for sizes 19 - 110 consists of two plates, with matched serrations, attached to the hanger frame with two or more cap screws and with a socketed piece which engages the position indicator. It is installed at the factory to hold the hanger in the "cold" position. A series of serrations can be engaged to lock the hanger at any position along the total travel range. The travel stop, which is furnished only when specified, is painted red. The stop must be removed before the piping system is put into operation, but not before the hanger is installed and fully loaded. The travel stop is released by removing the cap screws. A tag marked "Caution" and containing instructions for removal of the travel stop is attached to the hanger.

**Note:** See installation procedures PE-217-80 for a travel stop description on sizes 1-18.



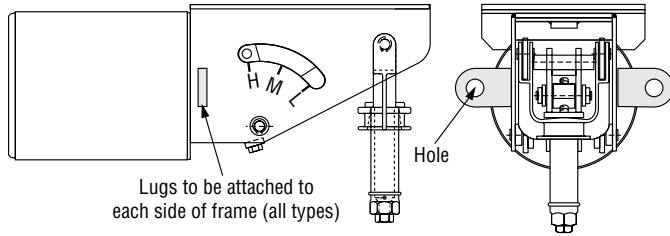
## Model R

(Continued)

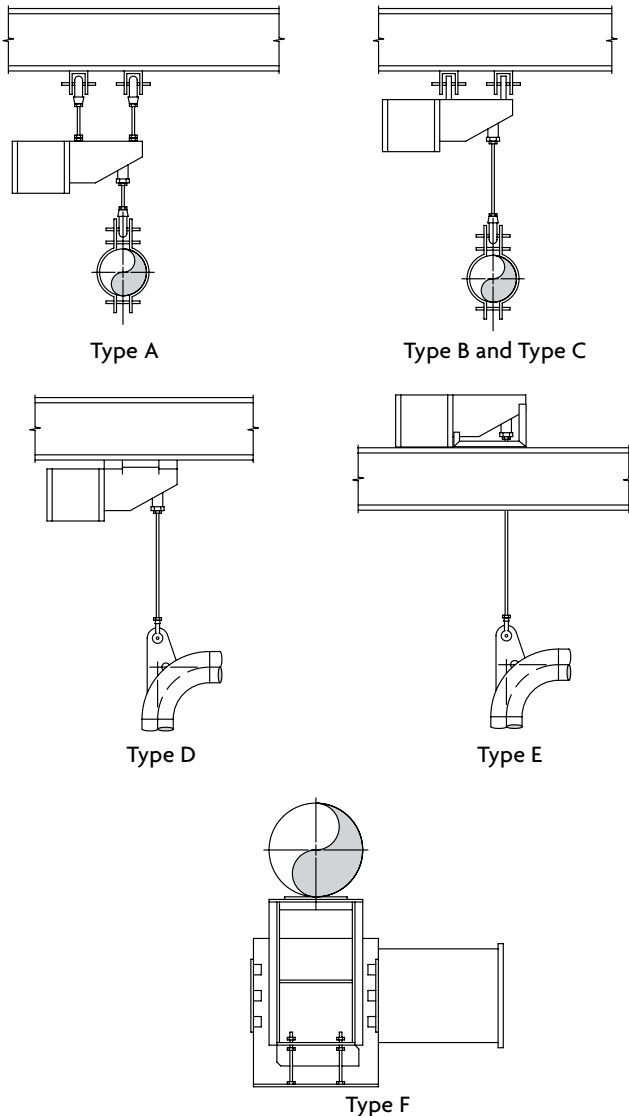
### Model R lifting lugs:

To help alleviate the problem of lifting large size Constant Supports into position for installation, this product is available with lifting lugs (if requested) on sizes ten and larger.

**Lifting Lugs (Figure 81-H):** Not available on Type F.

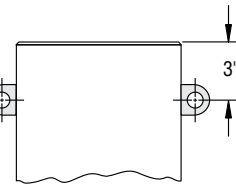


**Fig. 81-H (Horizontal):** Typical Applications

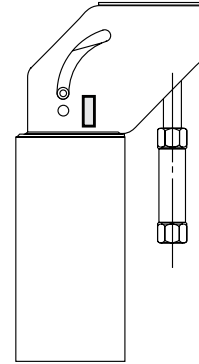


### Lifting Lugs (Fig 80-V):

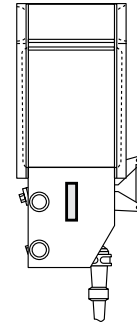
LUGS TO BE 90° FROM CHANNEL ON TYPE D



Types A, B, C, D, & E  
sizes 10 thru 63

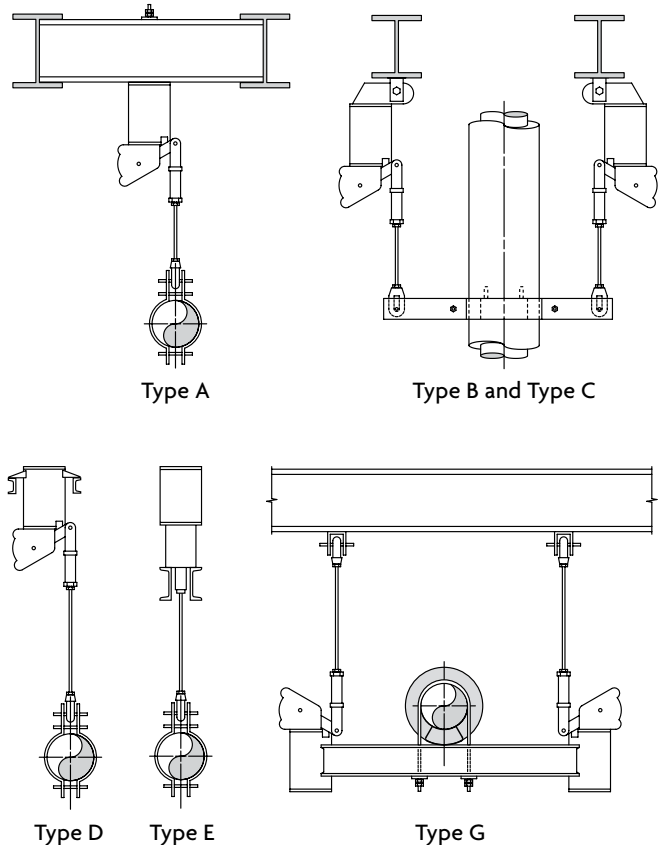


sizes 84 thru 110



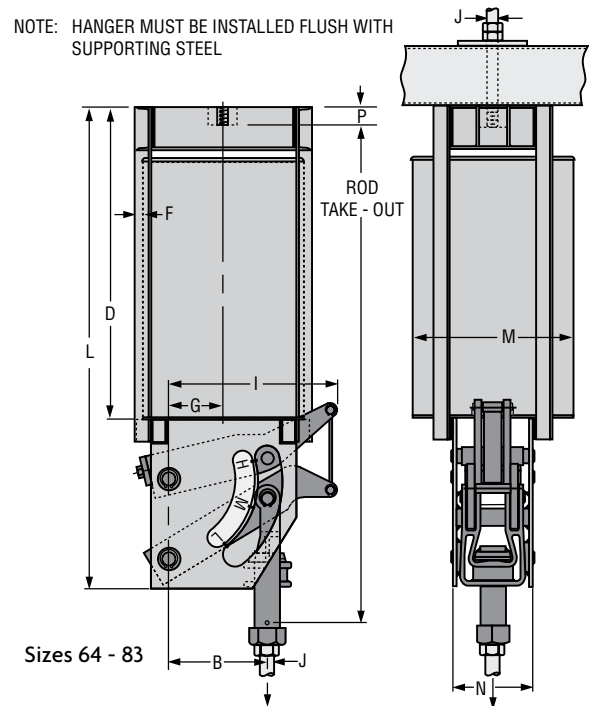
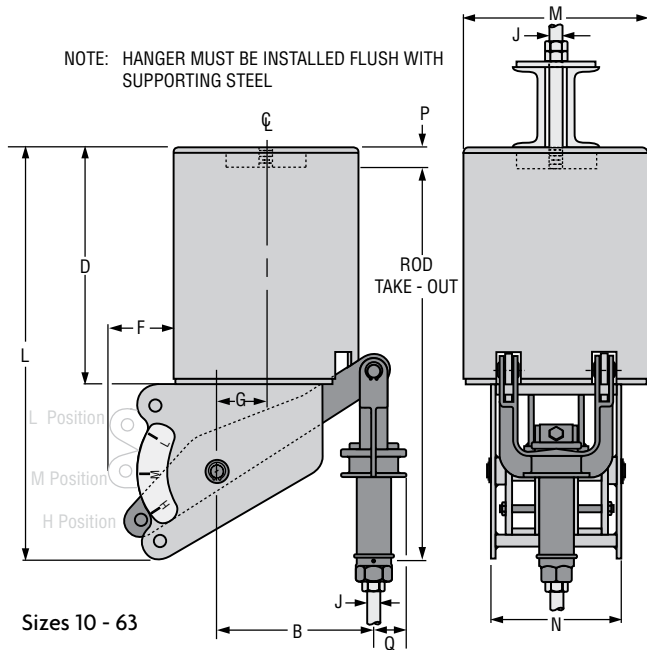
sizes 64 thru 83  
Lugs to be attached to each side of frame and will need stabilizing rigging when being lifted

**Fig. 80V (Vertical):** Typical Applications



## Fig. 80-V Type A

## Model R



**Type A** of the figure 80-V vertical design model R Constant Support Hanger is designed for attachment to its supporting member by screwing a rod into a tapped hole in the top cap of hanger a distance equal to the "P" dimension plus  $\frac{3}{8}$ ". Sight holes are provided near the top of the casing to allow visible inspection for correct thread engagement of upper hanger rod.

**Notes:** See load travel tables in the Pipe Hanger Catalog for the "B" dimension. For weights, see page 12 of this submittal. Location of travel indicator and contour of side plate may vary from that shown.

### FIG. 80-V, TYPE A: DIMENSIONS (IN)

Hanger Sizes	L	D	F	G	I	Dia. M	N	P	Q	Total Travel TT	Factors	J-rod		
												Min Thd Length	Rod Dia. Min Max	
1 - 9	Available in Fig. 81-H only													
10 - 18	18 <sup>7</sup> / <sub>8</sub>	8 <sup>7</sup> / <sub>8</sub>	2	1 <sup>1</sup> / <sub>2</sub>	•	8 <sup>5</sup> / <sub>8</sub>	6 <sup>7</sup> / <sub>16</sub>	7 <sup>7</sup> / <sub>8</sub>	1 <sup>3</sup> / <sub>8</sub>	5 or less 5 <sup>1</sup> / <sub>2</sub> or more	16 <sup>15</sup> / <sub>16</sub> 19 <sup>1</sup> / <sub>4</sub>	1 <sup>3</sup> / <sub>4</sub> + TT	1/2	3/4
19 - 34	28 <sup>1</sup> / <sub>2</sub>	16	2 <sup>1</sup> / <sub>8</sub>	2 <sup>5</sup> / <sub>8</sub>	•	12 <sup>3</sup> / <sub>4</sub>	8 <sup>9</sup> / <sub>16</sub>	1 <sup>1</sup> / <sub>8</sub>	1 <sup>5</sup> / <sub>8</sub>	5 or less 5 <sup>1</sup> / <sub>2</sub> or more	27 <sup>15</sup> / <sub>16</sub> 30 <sup>3</sup> / <sub>16</sub>	2 <sup>3</sup> / <sub>8</sub> + TT	1/2	1 <sup>1</sup> / <sub>4</sub>
35 - 49	32 <sup>3</sup> / <sub>4</sub>	18 <sup>1</sup> / <sub>4</sub>	4 <sup>3</sup> / <sub>4</sub>	3 <sup>3</sup> / <sub>4</sub>	•	14	9 <sup>13</sup> / <sub>16</sub>	1 <sup>1</sup> / <sub>2</sub>	2 <sup>1</sup> / <sub>2</sub>	6 or less 6 <sup>1</sup> / <sub>2</sub> or more	32 <sup>3</sup> / <sub>8</sub> 37	3 <sup>1</sup> / <sub>4</sub> + TT	1/2	1 <sup>3</sup> / <sub>4</sub>
50 - 63	46 <sup>7</sup> / <sub>8</sub>	28 <sup>1</sup> / <sub>8</sub>	8 <sup>5</sup> / <sub>16</sub>	5 <sup>7</sup> / <sub>8</sub>	•	18	11 <sup>1</sup> / <sub>4</sub>	2	3	11 or less 11 <sup>1</sup> / <sub>2</sub> or more	46 <sup>1</sup> / <sub>2</sub> 51 <sup>3</sup> / <sub>4</sub>	4 <sup>1</sup> / <sub>4</sub> + TT	3/4	2 <sup>1</sup> / <sub>4</sub>
64 - 74	67 <sup>1</sup> / <sub>2</sub>	44 <sup>1</sup> / <sub>4</sub>	1 <sup>1</sup> / <sub>16</sub>	7 <sup>1</sup> / <sub>2</sub>	25 <sup>3</sup> / <sub>8</sub>	22 <sup>3</sup> / <sub>16</sub>	11	2 <sup>1</sup> / <sub>2</sub>	-	10 <sup>1</sup> / <sub>2</sub> or less 11 or more	77 <sup>3</sup> / <sub>8</sub> 77 <sup>3</sup> / <sub>4</sub>	5 <sup>3</sup> / <sub>4</sub> + TT	1 <sup>1</sup> / <sub>4</sub>	2 <sup>3</sup> / <sub>4</sub>
75 - 83	69 <sup>1</sup> / <sub>2</sub>	46 <sup>1</sup> / <sub>4</sub>	1 <sup>1</sup> / <sub>2</sub>	7 <sup>1</sup> / <sub>2</sub>	25 <sup>3</sup> / <sub>8</sub>	27 <sup>3</sup> / <sub>16</sub>	11	3	-	10 <sup>1</sup> / <sub>2</sub> or less 11 or more	78 <sup>3</sup> / <sub>16</sub> 78 <sup>3</sup> / <sub>16</sub>	5 <sup>3</sup> / <sub>4</sub> + TT	1 <sup>1</sup> / <sub>2</sub>	3 <sup>1</sup> / <sub>4</sub>
84-110	See page 11 of submittal													

Rod take-out = (factor) - (TT / 2), for lever in high position.

• "I" dimension for sizes 10 through 63 equals "B" + "Q" Note: See the size selection chart in the Pipe Hanger Catalog for the "B" dimension.

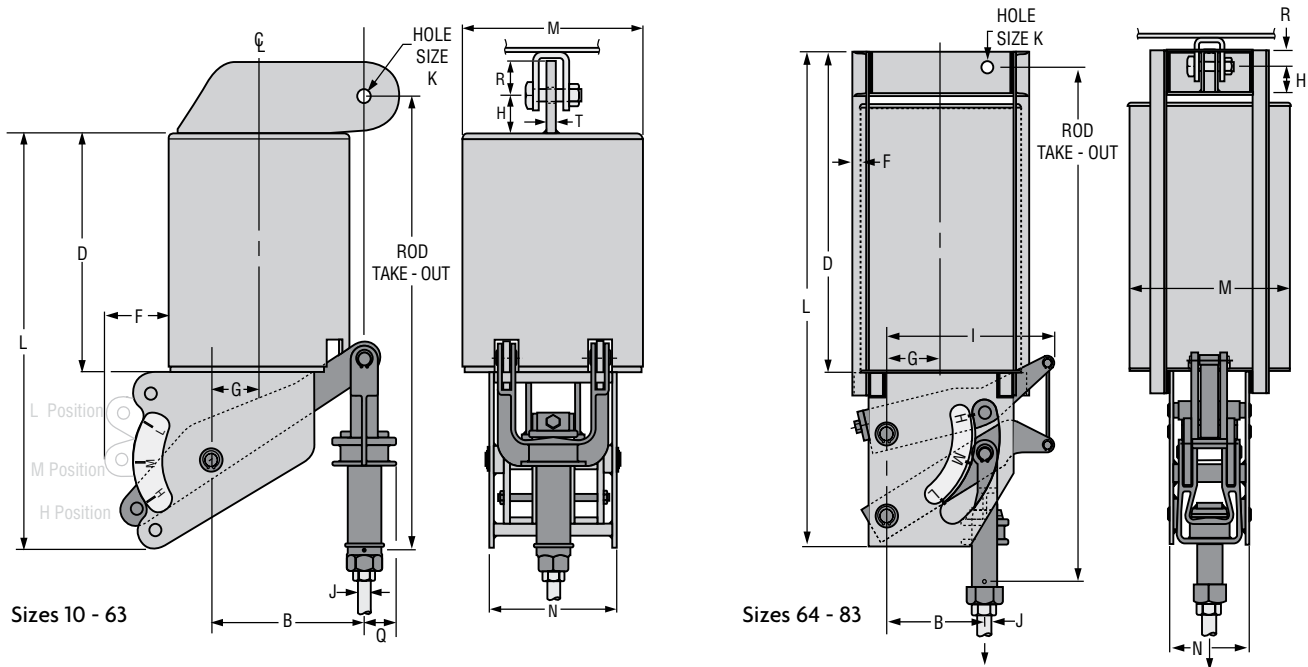
### J-ROD SELECTION CHART

Load (lbs)	0 800	801 1,500	1,501 2,540	2,541 4,000	4,001 6,100	6,101 9,400	9,401 13,400	13,401 18,300	18,301 24,700	24,701 31,000	31,001 39,000	39,001 48,000	48,001 58,000
J Rod Size	1/2	5/8	3/4	1	1 1/4	1 1/2	1 3/4	2	2 1/4	2 1/2	2 3/4	3	3 1/4*

\* 3/4 is furnished with 4 UNC series thread.

## Fig. 80-V Type B

## Model R



**Type B** is furnished with a single lug for attachment to the building structure. The lug permits use of a figure 66\* welded beam attachment, a figure 299 clevis or a pair of angles for attachment where headroom is limited.

**Notes:** See load travel tables in the Pipe Hanger Catalog for the “R” dimension. For weights, see page 12 of this submittal. Location of travel indicator and contour of side plate may vary from that shown.

### FIG. 80-V, TYPE B: DIMENSIONS (IN)

Hanger Size	L	D	F	G	H	I	Dia. M	N	Q	R	T	Total Travel TT	Factors	J-rod		
														Min Length	Thd Length	Min
1-9	Available in Fig. 81-H only															
10-18	18 <sup>7</sup> / <sub>8</sub>	8 <sup>7</sup> / <sub>8</sub>	2	1 <sup>1</sup> / <sub>2</sub>	1 <sup>1</sup> / <sub>2</sub>	•	8 <sup>5</sup> / <sub>8</sub>	6 <sup>7</sup> / <sub>16</sub>	1 <sup>3</sup> / <sub>8</sub>	1 <sup>1</sup> / <sub>2</sub>	3 <sup>8</sup> / <sub>16</sub>	5 or less 5 <sup>1</sup> / <sub>2</sub> or more	19 <sup>5</sup> / <sub>16</sub> 21 <sup>5</sup> / <sub>8</sub>	1 <sup>3</sup> / <sub>4</sub> + TT	1 <sup>1</sup> / <sub>2</sub>	3 <sup>4</sup> / <sub>4</sub>
19-34	28 <sup>1</sup> / <sub>2</sub>	16	2 <sup>1</sup> / <sub>8</sub>	2 <sup>5</sup> / <sub>8</sub>	2	•	12 <sup>3</sup> / <sub>4</sub>	8 <sup>9</sup> / <sub>16</sub>	1 <sup>5</sup> / <sub>8</sub>	1 <sup>1</sup> / <sub>2</sub>	5 <sup>8</sup> / <sub>16</sub>	5 or less 5 <sup>1</sup> / <sub>2</sub> or more	31 <sup>1</sup> / <sub>16</sub> 33 <sup>3</sup> / <sub>16</sub>	2 <sup>3</sup> / <sub>8</sub> + TT	1 <sup>1</sup> / <sub>2</sub>	1 <sup>1</sup> / <sub>4</sub>
35-49	32 <sup>3</sup> / <sub>4</sub>	18 <sup>1</sup> / <sub>4</sub>	4 <sup>3</sup> / <sub>4</sub>	3 <sup>3</sup> / <sub>4</sub>	3	•	14	9 <sup>13</sup> / <sub>16</sub>	2 <sup>1</sup> / <sub>2</sub>	1 <sup>1</sup> / <sub>4</sub> K-hole & smaller, 1 <sup>1</sup> / <sub>2</sub> 1 <sup>3</sup> / <sub>8</sub> K-hole and larger, 2	3 <sup>4</sup> / <sub>16</sub>	6 or less 6 <sup>1</sup> / <sub>2</sub> or more	36 <sup>7</sup> / <sub>8</sub> 41 <sup>1</sup> / <sub>2</sub>	3 <sup>1</sup> / <sub>4</sub> + TT	1 <sup>1</sup> / <sub>2</sub>	1 <sup>3</sup> / <sub>4</sub>
50-63	46 <sup>7</sup> / <sub>8</sub>	28 <sup>1</sup> / <sub>8</sub>	8 <sup>5</sup> / <sub>16</sub>	5 <sup>7</sup> / <sub>8</sub>	4	•	18	11 <sup>1</sup> / <sub>4</sub>	3	1 <sup>5</sup> / <sub>16</sub> K-hole, 1 <sup>1</sup> / <sub>2</sub> 1 <sup>1</sup> / <sub>8</sub> thru 1 <sup>1</sup> / <sub>2</sub> K-hole, 2 1 <sup>3</sup> / <sub>4</sub> K-hole and larger, 3	1	11 or less 11 <sup>1</sup> / <sub>2</sub> or more	52 <sup>1</sup> / <sub>2</sub> 57 <sup>3</sup> / <sub>4</sub>	4 <sup>1</sup> / <sub>4</sub> + TT	3 <sup>4</sup> / <sub>4</sub>	2 <sup>1</sup> / <sub>4</sub>
64-74	68	37 <sup>1</sup> / <sub>4</sub>	1 <sup>3</sup> / <sub>16</sub>	7 <sup>1</sup> / <sub>2</sub>	4 <sup>1</sup> / <sub>2</sub>	25 <sup>3</sup> / <sub>8</sub>	22 <sup>3</sup> / <sub>16</sub>	11	3 <sup>3</sup> / <sub>4</sub>	1 <sup>1</sup> / <sub>2</sub> K-hole, 2 1 <sup>3</sup> / <sub>4</sub> K-hole and larger, 3	2	10 <sup>1</sup> / <sub>2</sub> or less 11 or more	77 <sup>1</sup> / <sub>4</sub> 77 <sup>3</sup> / <sub>8</sub>	5 <sup>3</sup> / <sub>4</sub> + TT	1 <sup>1</sup> / <sub>4</sub>	2 <sup>3</sup> / <sub>4</sub>
75-83	69 <sup>1</sup> / <sub>2</sub>	38	1 <sup>1</sup> / <sub>2</sub>	7 <sup>1</sup> / <sub>2</sub>	3 <sup>5</sup> / <sub>8</sub>	25 <sup>3</sup> / <sub>8</sub>	27 <sup>3</sup> / <sub>16</sub>	11		3 <sup>3</sup> / <sub>4</sub>	2 <sup>1</sup> / <sub>2</sub>	10 <sup>1</sup> / <sub>2</sub> or less 11 or more	77 <sup>15</sup> / <sub>16</sub> 78 <sup>1</sup> / <sub>16</sub>	5 <sup>3</sup> / <sub>4</sub> + TT	1 <sup>1</sup> / <sub>2</sub>	3 <sup>1</sup> / <sub>4</sub>
84-110	See page 11 of submittal															

Rod take-out = (factor) - (TT / 2), for lever in high position. • “I” dimension for sizes 10 through 63 equals “B” + “Q”

\* For constant support sizes 50-63 and 64-74 where 1<sup>1</sup>/<sub>4</sub>" rod is required, check the “R” dimensions versus the Fig. 66 welded beam attachment dimensions for compatibility.

Note: See the size selection chart in the Pipe Hanger Catalog for the “B” dimension. K hole center line location is determined by the formula of “B - G = K Center Line”.

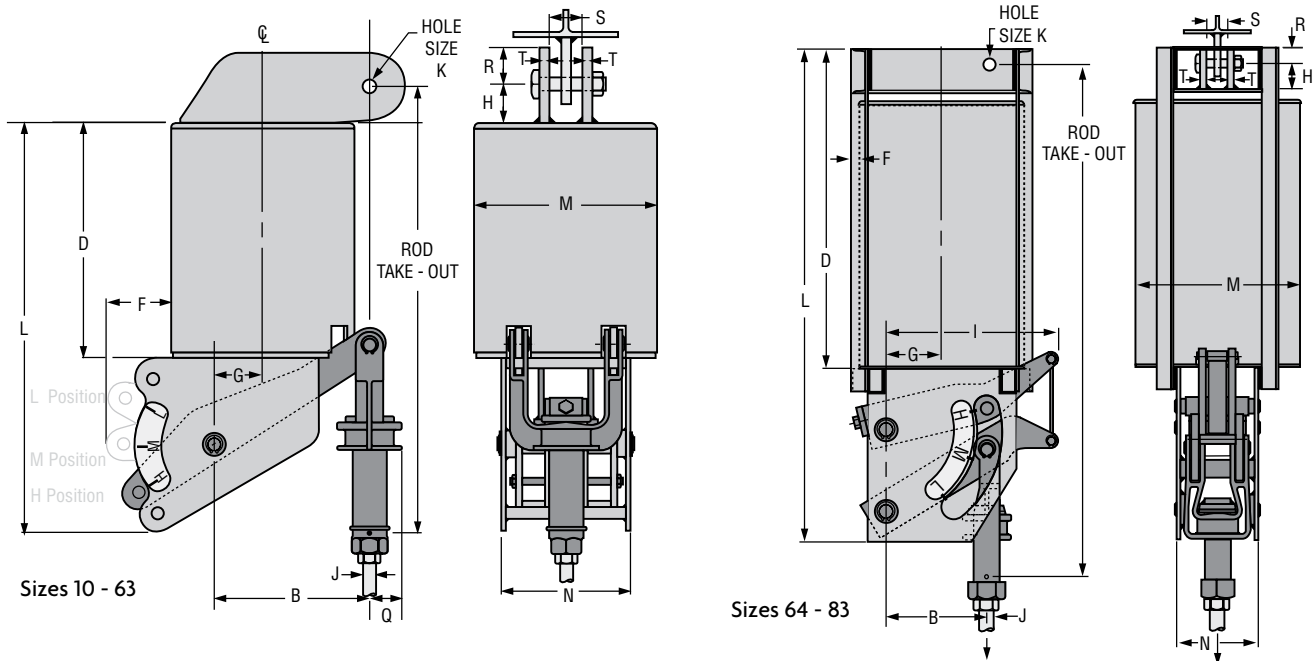
### J-ROD SELECTION CHART

Load (lbs)	0 800	801 1,500	1,501 2,540	2,541 4,000	4,001 6,100	6,101 9,400	9,401 13,400	13,401 18,300	18,301 24,700	24,701 31,000	31,001 39,000	39,001 48,000	48,001 58,000
J-Rod Size	1 <sup>1</sup> / <sub>2</sub>	5 <sup>8</sup> / <sub>16</sub>	3 <sup>4</sup> / <sub>4</sub>	1	1 <sup>1</sup> / <sub>4</sub>	1 <sup>1</sup> / <sub>2</sub>	1 <sup>3</sup> / <sub>4</sub>	2	2 <sup>1</sup> / <sub>4</sub>	2 <sup>1</sup> / <sub>2</sub>	2 <sup>3</sup> / <sub>4</sub>	3	3 <sup>1</sup> / <sub>4</sub> *
K-Hole	1 <sup>1</sup> / <sub>16</sub>	1 <sup>3</sup> / <sub>16</sub>	1 <sup>5</sup> / <sub>16</sub>	1 <sup>1</sup> / <sub>4</sub>	1 <sup>1</sup> / <sub>2</sub>	1 <sup>3</sup> / <sub>4</sub>	2	2 <sup>3</sup> / <sub>8</sub>	2 <sup>5</sup> / <sub>8</sub>	2 <sup>7</sup> / <sub>8</sub>	3 <sup>1</sup> / <sub>8</sub>	3 <sup>3</sup> / <sub>8</sub>	3 <sup>5</sup> / <sub>8</sub>

\* 3<sup>1</sup>/<sub>4</sub>" is furnished with 4 UNC series thread.

## Fig. 80-V Type C

### Model R



**Type C** is furnished with a pair of lugs for attachment to the building structure. These lugs permit the use of an eye rod or a single plate for attachment where headroom is limited.

**Notes:** See load travel tables in the Pipe Hanger Catalog for the “B” dimension. For weights, see page 12 of this submittal. Location of travel indicator and contour of side plate may vary from that shown.

### FIG. 80-V, TYPE C: DIMENSIONS (IN)

Hanger Size	L	D	F	G	H	I	Dia. M	N	Q	R	T	Total Travel TT	Factors	J-rod		
														Min	Thd Length	Rod Dia. Max
1-9	Available in Fig. 81-H only															
10-18	18 <sup>7</sup> / <sub>8</sub>	8 <sup>7</sup> / <sub>8</sub>	2	1 <sup>1</sup> / <sub>2</sub>	1 <sup>1</sup> / <sub>2</sub>	•	8 <sup>5</sup> / <sub>8</sub>	6 <sup>7</sup> / <sub>16</sub>	1 <sup>3</sup> / <sub>8</sub>	1 <sup>1</sup> / <sub>2</sub>	3 <sup>3</sup> / <sub>8</sub>	5 or less 5 <sup>1</sup> / <sub>2</sub> or more	19 <sup>5</sup> / <sub>16</sub> 21 <sup>5</sup> / <sub>16</sub>	1 <sup>3</sup> / <sub>4</sub> + TT	1 <sup>1</sup> / <sub>2</sub>	3 <sup>3</sup> / <sub>4</sub>
19-34	28 <sup>1</sup> / <sub>2</sub>	16	2 <sup>1</sup> / <sub>8</sub>	2 <sup>5</sup> / <sub>8</sub>	2	•	12 <sup>3</sup> / <sub>4</sub>	8 <sup>9</sup> / <sub>16</sub>	1 <sup>5</sup> / <sub>8</sub>	1 <sup>1</sup> / <sub>2</sub>	5 <sup>5</sup> / <sub>8</sub>	5 or less 5 <sup>1</sup> / <sub>2</sub> or more	31 <sup>1</sup> / <sub>16</sub> 33 <sup>3</sup> / <sub>16</sub>	2 <sup>3</sup> / <sub>8</sub> + TT	1 <sup>1</sup> / <sub>2</sub>	1 <sup>1</sup> / <sub>4</sub>
35-49	32 <sup>3</sup> / <sub>4</sub>	18 <sup>1</sup> / <sub>4</sub>	4 <sup>3</sup> / <sub>4</sub>	3 <sup>3</sup> / <sub>4</sub>	3	•	14	9 <sup>13</sup> / <sub>16</sub>	2 <sup>1</sup> / <sub>2</sub>	1 <sup>1</sup> / <sub>4</sub> K-hole & smaller, 1 <sup>1</sup> / <sub>2</sub> 1 <sup>3</sup> / <sub>8</sub> K-hole and larger, 2	3 <sup>3</sup> / <sub>4</sub>	6 or less 6 <sup>1</sup> / <sub>2</sub> or more	36 <sup>7</sup> / <sub>8</sub> 41 <sup>1</sup> / <sub>2</sub>	3 <sup>1</sup> / <sub>4</sub> + TT	1 <sup>1</sup> / <sub>2</sub>	1 <sup>3</sup> / <sub>4</sub>
50-63	46 <sup>7</sup> / <sub>8</sub>	28 <sup>1</sup> / <sub>8</sub>	8 <sup>5</sup> / <sub>16</sub>	5 <sup>7</sup> / <sub>8</sub>	4	•	18	11 <sup>1</sup> / <sub>4</sub>	3	1 <sup>1</sup> / <sub>8</sub> thru 1 <sup>3</sup> / <sub>8</sub> K-hole, 2 1 <sup>1</sup> / <sub>2</sub> K-hole and larger, 3	1	11 or less 11 <sup>1</sup> / <sub>2</sub> or more	52 <sup>1</sup> / <sub>2</sub> 57 <sup>3</sup> / <sub>4</sub>	4 <sup>1</sup> / <sub>4</sub> + TT	3 <sup>3</sup> / <sub>4</sub>	2 <sup>1</sup> / <sub>4</sub>
64-74	68	36 <sup>3</sup> / <sub>4</sub>	1 <sup>3</sup> / <sub>16</sub>	7 <sup>1</sup> / <sub>2</sub>	5	25 <sup>3</sup> / <sub>8</sub>	22 <sup>3</sup> / <sub>16</sub>	11	3 <sup>1</sup> / <sub>4</sub>	3	1 <sup>1</sup> / <sub>2</sub>	10 <sup>1</sup> / <sub>2</sub> or less 11 or more	77 <sup>1</sup> / <sub>4</sub> 77 <sup>3</sup> / <sub>8</sub>	5 <sup>3</sup> / <sub>4</sub> + TT	1 <sup>1</sup> / <sub>4</sub>	2 <sup>3</sup> / <sub>4</sub>
75-83	69 <sup>1</sup> / <sub>2</sub>	37 <sup>1</sup> / <sub>4</sub>	1 <sup>1</sup> / <sub>2</sub>	7 <sup>1</sup> / <sub>2</sub>	6 <sup>1</sup> / <sub>4</sub>	25 <sup>3</sup> / <sub>8</sub>	27 <sup>3</sup> / <sub>16</sub>	11	3 <sup>1</sup> / <sub>4</sub>	3 <sup>3</sup> / <sub>4</sub>	1	10 <sup>1</sup> / <sub>2</sub> or less 11 or more	77 <sup>15</sup> / <sub>16</sub> 78 <sup>1</sup> / <sub>16</sub>	5 <sup>3</sup> / <sub>4</sub> + TT	1 <sup>1</sup> / <sub>2</sub>	3 <sup>1</sup> / <sub>4</sub> *
84-110	See page 11 of submittal															

Rod take-out = (factor) - (TT / 2), for lever in high position. • “I” dimension for sizes 10 through 63 equals “B” + “Q”

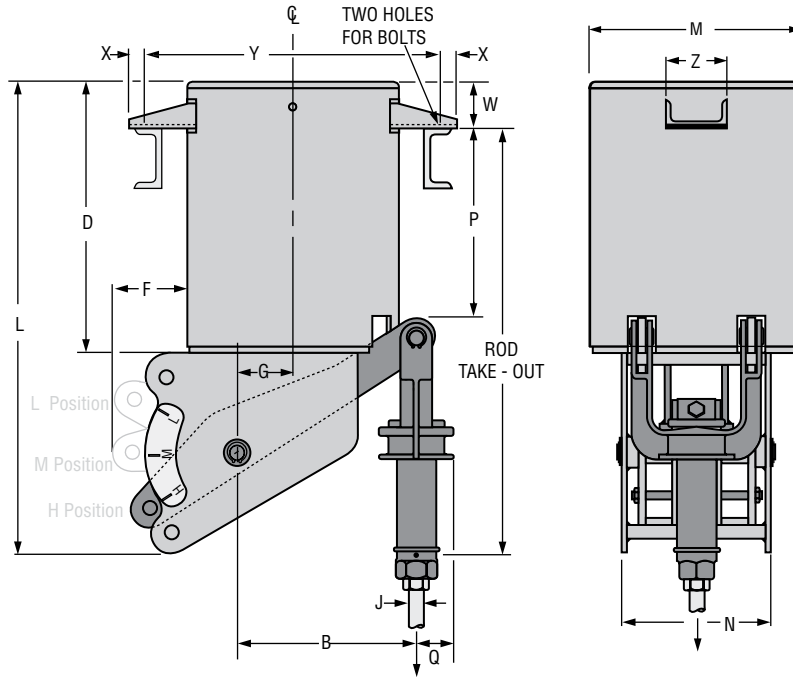
Note: See the size selection chart in the Pipe Hanger Catalog for the “B” dimension. K hole center line location is determined by the formula of “B - G = K Center Line”.

Load (lbs)	0 800	801 1,500	1,501 2,540	2,541 4,000	4,001 6,100	6,101 9,400	9,401 13,400	13,401 18,300	18,301 24,700	24,701 31,000	31,001 39,000	39,001 48,000	48,001 58,000
J-Rod Size	1/2	5/8	3/4	1	1 1/4	1 1/2	1 3/4	2	2 1/4	2 1/2	2 3/4	3	3 1/4*
K-Hole Size	1 1/16	1 3/16	1 5/16	1 1/4	1 1/2	1 3/4	2	2 3/8	2 5/8	2 7/8	3 1/8	3 3/8	3 5/8
S	7/8	1 1/16	1 1/4	1 5/8	2	2 3/8	2 5/8	2 7/8	3 1/8	3 3/8	3 5/8	3 7/8	4 1/8

\* 3 1/4" is furnished with 4 UNC series thread.

## Fig. 80-V Type D

### Model R



**Type D** rests on top of structural steel while most of the Constant Support itself hangs between or below the supporting beams. The depth of the beam is limited by the "P" dimension. Dimension "P" can be varied on special order, however, "P" dimension shown is maximum for the hanger.

**Notes:** See load travel tables in the Pipe Hanger Catalog for the "B" dimension. For weights, see page 12 of this submittal. Location of travel indicator and contour of side plate may vary from that shown.

### FIG. 80-V: DIMENSIONS (IN)

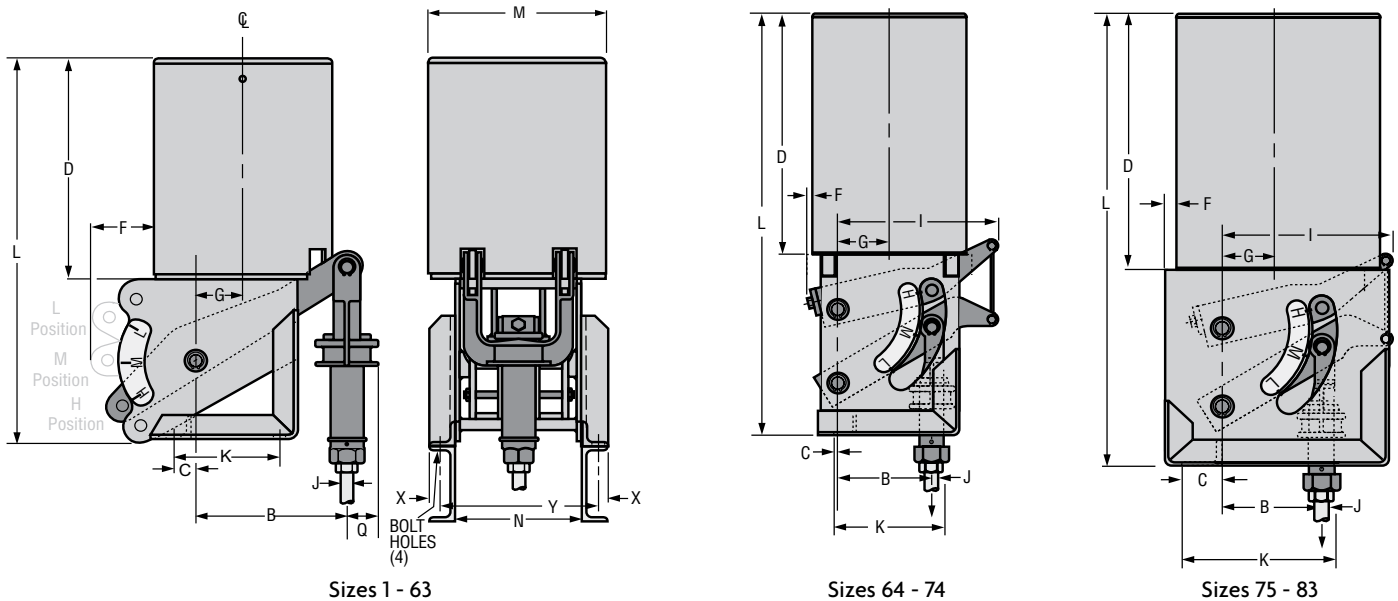
Hanger Sizes	L	D	F	G	Dia. M	N	Q	P	W	X	Y	Z	Bracket Hole Dia.	Total Travel TT	Factors	J-Rod		
																Min Thd Length	Min Dia.	Max Dia.
1-9	Available in Fig. 81-H only																	
10-18	18 <sup>7</sup> / <sub>8</sub>	8 <sup>7</sup> / <sub>8</sub>	2	1 <sup>1</sup> / <sub>2</sub>	8 <sup>5</sup> / <sub>8</sub>	6 <sup>7</sup> / <sub>16</sub>	1 <sup>3</sup> / <sub>8</sub>	4 <sup>15</sup> / <sub>16</sub>	2 <sup>3</sup> / <sub>8</sub>	1 <sup>1</sup> / <sub>2</sub>	10 <sup>3</sup> / <sub>4</sub>	3	3/4	5 or less 5 <sup>1</sup> / <sub>2</sub> or more	15 <sup>1</sup> / <sub>2</sub> 17 <sup>3</sup> / <sub>16</sub>	1 <sup>3</sup> / <sub>4</sub> + TT	1/2	3/4
19-34	28 <sup>1</sup> / <sub>2</sub>	16	2 <sup>1</sup> / <sub>8</sub>	2 <sup>5</sup> / <sub>8</sub>	12 <sup>3</sup> / <sub>4</sub>	8 <sup>9</sup> / <sub>16</sub>	1 <sup>5</sup> / <sub>8</sub>	12 <sup>1</sup> / <sub>2</sub>	2 <sup>3</sup> / <sub>8</sub>	1 <sup>1</sup> / <sub>2</sub>	14 <sup>7</sup> / <sub>8</sub>	3	7/8	5 or less 5 <sup>1</sup> / <sub>2</sub> or more	26 <sup>11</sup> / <sub>16</sub> 28 <sup>13</sup> / <sub>16</sub>	2 <sup>3</sup> / <sub>8</sub> + TT	1/2	1 <sup>1</sup> / <sub>4</sub>
35-49	32 <sup>3</sup> / <sub>4</sub>	18 <sup>1</sup> / <sub>4</sub>	4 <sup>3</sup> / <sub>4</sub>	3 <sup>3</sup> / <sub>4</sub>	14	9 <sup>13</sup> / <sub>16</sub>	2 <sup>1</sup> / <sub>2</sub>	13 <sup>1</sup> / <sub>4</sub>	2 <sup>5</sup> / <sub>8</sub>	2	16 <sup>3</sup> / <sub>4</sub>	4	1 <sup>1</sup> / <sub>8</sub>	6 or less 6 <sup>1</sup> / <sub>2</sub> or more	31 <sup>1</sup> / <sub>4</sub> 35 <sup>7</sup> / <sub>8</sub>	3 <sup>1</sup> / <sub>4</sub> + TT	1/2	1 <sup>3</sup> / <sub>4</sub>
50-63	46 <sup>7</sup> / <sub>8</sub>	28 <sup>1</sup> / <sub>8</sub>	8 <sup>5</sup> / <sub>16</sub>	5 <sup>7</sup> / <sub>8</sub>	18	11 <sup>1</sup> / <sub>4</sub>	3	24 <sup>1</sup> / <sub>2</sub>	2 <sup>7</sup> / <sub>8</sub>	3	21	6	1 <sup>3</sup> / <sub>8</sub>	11 or less 11 <sup>1</sup> / <sub>2</sub> or more	45 <sup>9</sup> / <sub>16</sub> 50 <sup>7</sup> / <sub>8</sub>	4 <sup>1</sup> / <sub>4</sub> + TT	3/4	2 <sup>1</sup> / <sub>4</sub>
64-83	Available in Fig. 81-H only.																	
84-110	Not Available																	

\*Rod take-out = (factor) - (TT / 2), for lever in high position. • "I" dimension for sizes 10 through 63 equals "B" + "Q"  
Note: See the size selection chart in the Pipe Hanger Catalog for the "B" dimension.

Load (lbs)	0 800	801 1,500	1,501 2,540	2,541 4,000	4,001 6,100	6,101 9,400	9,401 13,400	13,401 18,300	18,301 24,700
J Rod Size	1/2	5/8	3/4	1	1 <sup>1</sup> / <sub>4</sub>	1 <sup>1</sup> / <sub>2</sub>	1 <sup>3</sup> / <sub>4</sub>	2	2 <sup>1</sup> / <sub>4</sub>

## Fig. 80-V Type E

## Model R



**Type E** rests on top flange of structural steel and the constant support itself is entirely above the supporting beams. If the rod takeout does not exceed the depth of the supporting steel and the rod coupling must extend below the steel, specify the depth of the supporting steel. Increase the rod take-out by the depth of the steel.

**Notes:** See load travel tables in the Pipe Hanger Catalog for the “B” dimension. For weights, see page 12 of this submittal. Location of travel indicator and contour of side plate may vary from that shown.

### FIG. 80-V, TYPE E: DIMENSIONS (IN)

Hanger Size	L	C	D	F	G	I	K	Dia. M	X	Y	N	Q	Angle Size	Bracket Hole Dia.	Total Travel TT	Factors	J-Rod	
																	Min Thd Length	Rod Dia Min Max
1-9	Available in Fig. 81-H Only																	
10-18	18 <sup>7</sup> / <sub>8</sub>	1 <sup>1</sup> / <sub>2</sub>	8 <sup>7</sup> / <sub>8</sub>	2	1 <sup>1</sup> / <sub>2</sub>	•	4 <sup>5</sup> / <sub>16</sub>	8 <sup>5</sup> / <sub>8</sub>	5 <sup>5</sup> / <sub>8</sub>	8 <sup>15</sup> / <sub>16</sub>	6 <sup>7</sup> / <sub>16</sub>	1 <sup>3</sup> / <sub>8</sub>	1 <sup>1</sup> / <sub>2</sub> x 2 x 1/4	3/4	5 or less 5 <sup>1</sup> / <sub>2</sub> or more	1 <sup>7</sup> / <sub>16</sub> 3 <sup>3</sup> / <sub>4</sub>	1 <sup>3</sup> / <sub>4</sub> + TT	1/2 3/4
19-34	28 <sup>1</sup> / <sub>2</sub>	1 <sup>3</sup> / <sub>16</sub>	16	2 <sup>1</sup> / <sub>8</sub>	2 <sup>5</sup> / <sub>8</sub>	•	6 <sup>1</sup> / <sub>16</sub>	12 <sup>3</sup> / <sub>4</sub>	5 <sup>5</sup> / <sub>8</sub>	11 <sup>3</sup> / <sub>16</sub>	8 <sup>9</sup> / <sub>16</sub>	1 <sup>5</sup> / <sub>8</sub>	1 <sup>1</sup> / <sub>2</sub> x 2 <sup>1</sup> / <sub>2</sub> x 1/4	3/4	5 or less 5 <sup>1</sup> / <sub>2</sub> or more	2 <sup>13</sup> / <sub>16</sub> 4 <sup>15</sup> / <sub>16</sub>	2 <sup>3</sup> / <sub>8</sub> + TT	1/2 1 <sup>1</sup> / <sub>4</sub>
35-49	32 <sup>3</sup> / <sub>4</sub>	1 <sup>7</sup> / <sub>8</sub>	18 <sup>1</sup> / <sub>4</sub>	4 <sup>3</sup> / <sub>4</sub>	3 <sup>3</sup> / <sub>4</sub>	•	8 <sup>5</sup> / <sub>16</sub>	14	1 <sup>3</sup> / <sub>16</sub>	13 <sup>5</sup> / <sub>16</sub>	9 <sup>13</sup> / <sub>16</sub>	2 <sup>1</sup> / <sub>2</sub>	3 x 2 x 3/8	7/8	6 or less 6 <sup>1</sup> / <sub>2</sub> or more	2 <sup>1</sup> / <sub>2</sub> 7 <sup>1</sup> / <sub>8</sub>	3 <sup>1</sup> / <sub>4</sub> + TT	1/2 1 <sup>3</sup> / <sub>4</sub>
50-63	46 <sup>7</sup> / <sub>8</sub>	3 <sup>3</sup> / <sub>4</sub>	28 <sup>1</sup> / <sub>8</sub>	8 <sup>5</sup> / <sub>16</sub>	5 <sup>7</sup> / <sub>8</sub>	•	12 <sup>13</sup> / <sub>16</sub>	18	1 <sup>5</sup> / <sub>16</sub>	14 <sup>1</sup> / <sub>16</sub>	11 <sup>1</sup> / <sub>4</sub>	3	3 x 3 x 3/8	1 <sup>3</sup> / <sub>8</sub>	11 or less 11 <sup>1</sup> / <sub>2</sub> or more	1 <sup>5</sup> / <sub>8</sub> 7	4 <sup>1</sup> / <sub>4</sub> + TT	3/4 2 <sup>1</sup> / <sub>4</sub>
64-74	62	3/8	35 <sup>3</sup> / <sub>4</sub>	3/8	7 <sup>1</sup> / <sub>2</sub>	25 <sup>3</sup> / <sub>8</sub>	15 <sup>3</sup> / <sub>4</sub>	22 <sup>3</sup> / <sub>16</sub>	1 <sup>9</sup> / <sub>16</sub>	14 <sup>15</sup> / <sub>16</sub>	11	3	3 <sup>1</sup> / <sub>2</sub> x 3 <sup>1</sup> / <sub>2</sub> x 1/2	1 <sup>5</sup> / <sub>8</sub>	11 or more	9 <sup>1</sup> / <sub>4</sub>	5 <sup>3</sup> / <sub>4</sub> + TT	1 <sup>1</sup> / <sub>4</sub> 2 <sup>3</sup> / <sub>4</sub>
75-83	62 <sup>1</sup> / <sub>2</sub>	5 <sup>1</sup> / <sub>4</sub>	35 <sup>3</sup> / <sub>4</sub>	1 <sup>1</sup> / <sub>2</sub>	7 <sup>1</sup> / <sub>2</sub>	25 <sup>3</sup> / <sub>8</sub>	25 <sup>5</sup> / <sub>8</sub>	27 <sup>3</sup> / <sub>16</sub>	1 <sup>3</sup> / <sub>4</sub>	15 <sup>1</sup> / <sub>2</sub>	11	3	4 x 4 x 3/8	1 <sup>5</sup> / <sub>8</sub>	10 <sup>1</sup> / <sub>2</sub> or less 11 or more	8 <sup>3</sup> / <sub>4</sub> 8 <sup>7</sup> / <sub>8</sub>	5 <sup>3</sup> / <sub>4</sub> + TT	1 <sup>1</sup> / <sub>2</sub> 3 <sup>1</sup> / <sub>4</sub>
84-110	Not Available																	

Rod take-out = (factor) - (TT / 2), for lever in high position. Rod take-out is measured from the bottom of the supporting angles to the center of the load coupling site hole.  
 • “I” dimension for sizes 10 through 63 equals “B” + “Q” Note: See the size selection chart in the Pipe Hanger Catalog for the “B” dimension.

### J-ROD SELECTION CHART

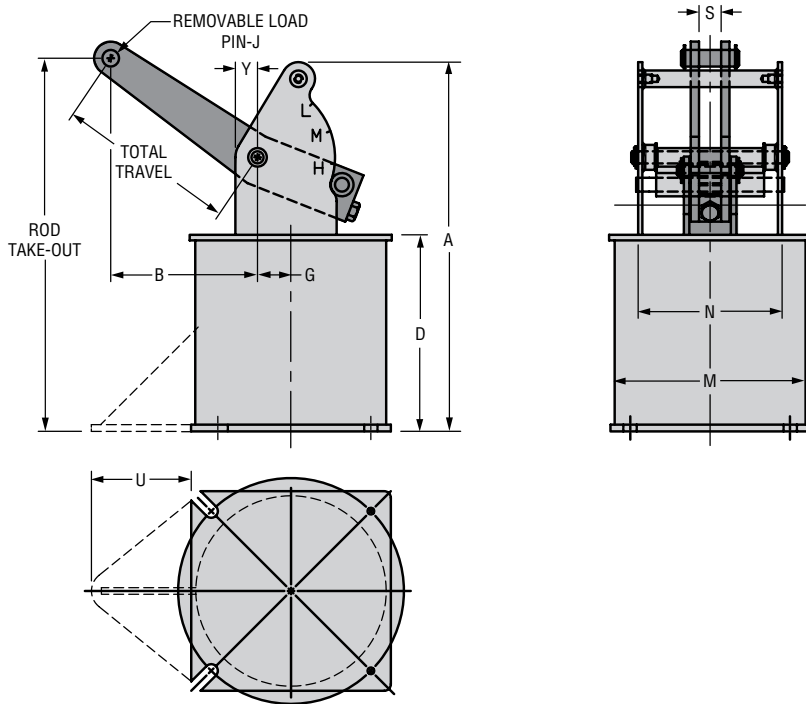
Load (lbs)	0 800	801 1,500	1,501 2,540	2,541 4,000	4,001 6,100	6,101 9,400	9,401 13,400	13,401 18,300	18,301 24,700	24,701 31,000	31,001 39,000	39,001 48,000	48,001 58,000
J Rod Size	1/2	5/8	3/4	1	1 <sup>1</sup> / <sub>4</sub>	1 <sup>1</sup> / <sub>2</sub>	1 <sup>3</sup> / <sub>4</sub>	2	2 <sup>1</sup> / <sub>4</sub>	2 <sup>1</sup> / <sub>2</sub>	2 <sup>3</sup> / <sub>4</sub>	3	3 <sup>1</sup> / <sub>4</sub> *

\* 3<sup>1</sup>/<sub>4</sub>" is furnished with 4 UNC series thread.



## Fig. 80-V Type F

Model R



Hanger Size	Total Travel	U
10-18	1½ - 4½	-
	5 - 8	5
19-34	2 - 6½	-
	7 - 10	7¼
35-49	2½ - 6	-
	6½ - 9	7
	9½ - 14	11½
50-63	3 - 6½	-
	7 - 10	8½
	10½ - 16	14

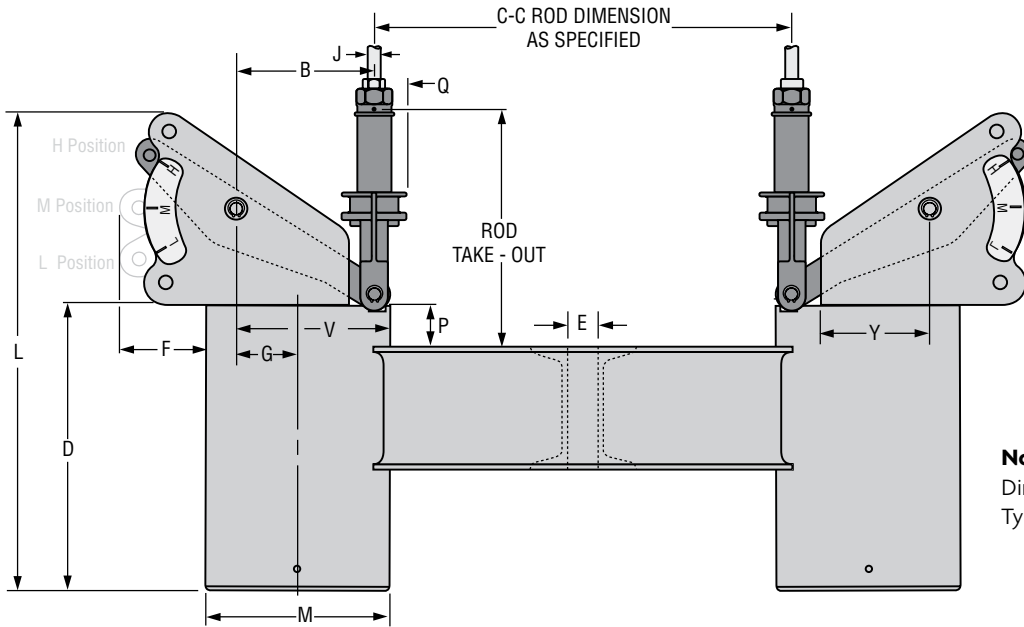
**Type F** is for support of piping or equipment from below. It has a base flange for fastening to the floor or to beams. The load arm is furnished with a removable load pin. The intermediate strut which runs from the load arm to the piping is not furnished and must be ordered separately, designed to the specific requirement.

**Note:** See load travel table for "B" dimension.

Hanger Size	A	D	G	M	N	S	Y	Bottom Flange Square	Bottom Flange Bolt Circle	Flange Hole and Slot Dia.	Flange Thickness	Factor	Total Travel	J Dia.
1-9	Not Available													
10-18	16 <sup>5</sup> / <sub>8</sub>	8 <sup>3</sup> / <sub>4</sub>	1½	8 <sup>5</sup> / <sub>8</sub>	6¼	1	1	9	10	7/16	¼	12 <sup>5</sup> / <sub>8</sub>	5½ or less	¾
													6 or more	½
19-34	25 <sup>3</sup> / <sub>8</sub>	14 <sup>11</sup> / <sub>16</sub>	2 <sup>5</sup> / <sub>8</sub>	12 <sup>3</sup> / <sub>4</sub>	8 <sup>3</sup> / <sub>8</sub>	1 <sup>5</sup> / <sub>16</sub>	1	13¼	15	5/8	3/8	20 <sup>1</sup> / <sub>8</sub>	4 or less	1 <sup>1</sup> / <sub>8</sub>
													4½ or more	7/8
35-49	32 <sup>5</sup> / <sub>8</sub>	18½	3 <sup>11</sup> / <sub>16</sub>	14	9 <sup>15</sup> / <sub>16</sub>	2¼	1½	14½	17	7/8	5/8	25½	7 or less	1½
													7½ or more	1 <sup>1</sup> / <sub>8</sub>
50-63	48 <sup>3</sup> / <sub>4</sub>	28 <sup>5</sup> / <sub>8</sub>	5 <sup>7</sup> / <sub>8</sub>	18	11¼	2¼	1 <sup>5</sup> / <sub>8</sub>	18½	21	1 <sup>1</sup> / <sub>8</sub>	¾	38½	8 or less	2
													8½ or more	1½
64-110	Not Available													

## Fig. 80-V Type G

### Model R



**Note:** For orientation of "N" Dimension, see Fig. 80-V Type D.

**Type G** is a complete trapeze assembly. The hanger consists of two vertical type Constant Support units plus a pair of channels, back-to-back, welded at each end to the hanger casing. In sizing a Type G hanger, it must be remembered that each standard spring unit carries one-half of the total pipe load. Furthermore, the weights of the hanger itself must be considered as part of the overall load. Therefore, using one-half the total pipe load, select the required hanger size from the Load Travel Table and add one-half the weight of the size hanger selected to one-half the total pipe load. If the load now exceeds the maximum load at the required total travel for the hanger size selected, it is necessary to go to the next larger hanger. If the pipe line is designed so as not to be centered on the channel, one

spring of the trapeze will carry a heavier load than the other and care must be taken in sizing the individual hanger units. The center-to-center rod dimension must be specified when ordering. The minimum C-C dimension can be determined as follows:

$B \text{ plus } Q > Y: (\text{O.D. of pipe covering}) + 2Q.$

$B \text{ plus } Q < Y: (\text{O.D. of pipe covering}) + 2(Y - B).$

**Note:** If U-bolt is used to fasten pipe to channels, C-C of U-bolt tangents plus one washer plate width cannot be greater than C-C of the hanger rods minus 2 (V minus B). See load travel tables in the Pipe Hanger Catalog for "B" dimension.

For weights, see page 12 of this submittal. Location of travel indicator and contour of side plate may vary from that shown.

### FIG. 80-V, TYPE G: DIMENSIONS (IN)

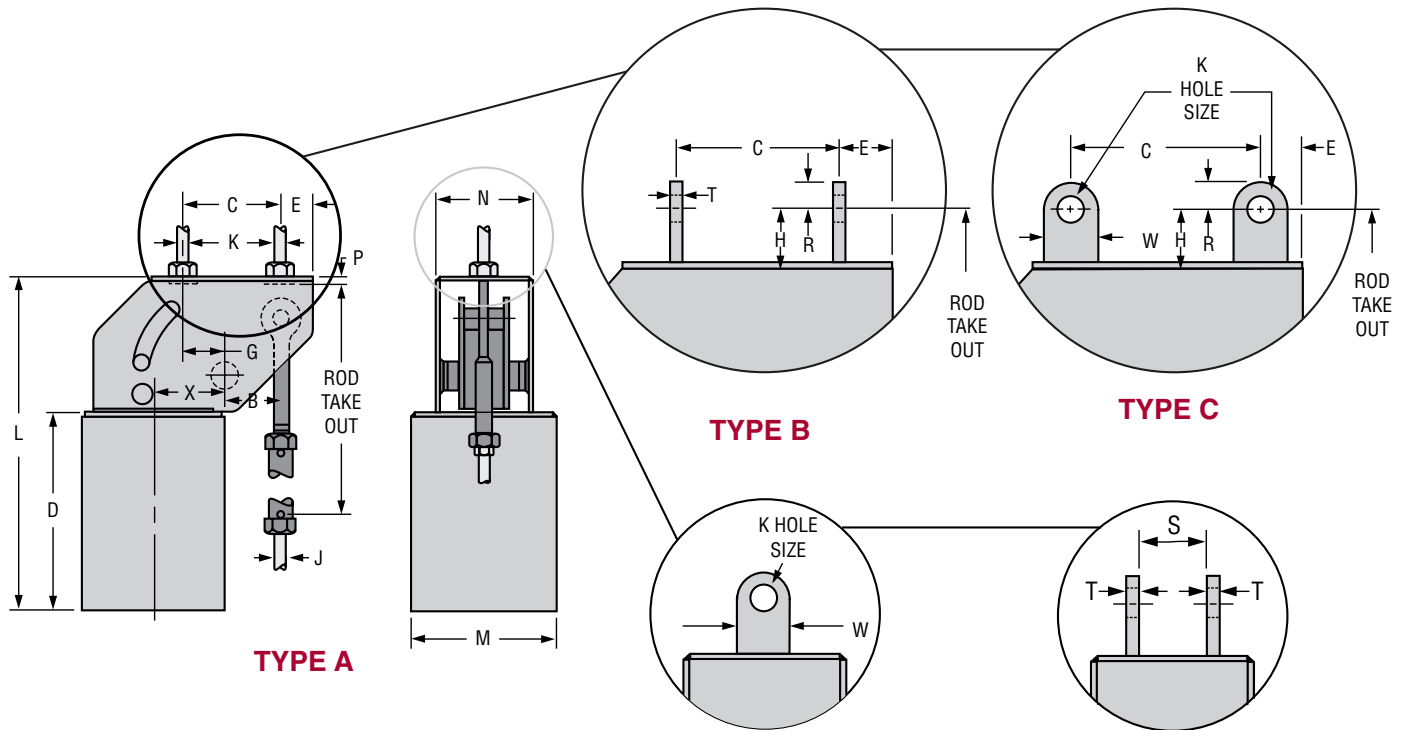
Hanger Size	L	D	E	F	G	Dia M	N	P	Q	V	Y	Channel Size (lbs/ft)	C - C	Total Travel TT	Factors	J-Rod		
																Min Thread Length	Min Rod Dia.	Max Rod Dia.
1-9	Not available																	
10-18	18 <sup>7</sup> / <sub>8</sub>	8 <sup>7</sup> / <sub>8</sub>	1	2	1 <sup>1</sup> / <sub>2</sub>	8 <sup>5</sup> / <sub>8</sub>	6 <sup>7</sup> / <sub>16</sub>	2 <sup>9</sup> / <sub>16</sub>	1 <sup>3</sup> / <sub>8</sub>	5 <sup>13</sup> / <sub>16</sub>	6 <sup>5</sup> / <sub>8</sub>	4 @ 5.4	30	5 or less 5 <sup>1</sup> / <sub>2</sub> or more	11 <sup>11</sup> / <sub>16</sub> 14	1 <sup>3</sup> / <sub>4</sub> + TT	1/2	3/4
19-34	28 <sup>1</sup> / <sub>2</sub>	16	1 <sup>1</sup> / <sub>4</sub>	2 <sup>1</sup> / <sub>8</sub>	2 <sup>5</sup> / <sub>8</sub>	12 <sup>3</sup> / <sub>4</sub>	8 <sup>9</sup> / <sub>16</sub>	3 <sup>9</sup> / <sub>16</sub>	1 <sup>5</sup> / <sub>8</sub>	9	9 <sup>5</sup> / <sub>8</sub>	6 @ 10.5	42	5 or less 5 <sup>1</sup> / <sub>2</sub> or more	16 <sup>13</sup> / <sub>16</sub> 18 <sup>3</sup> / <sub>4</sub>	2 <sup>3</sup> / <sub>8</sub> + TT	1/2	1 <sup>1</sup> / <sub>4</sub>
35-49	32 <sup>3</sup> / <sub>4</sub>	18 <sup>1</sup> / <sub>4</sub>	1 <sup>1</sup> / <sub>2</sub>	4 <sup>3</sup> / <sub>4</sub>	3 <sup>3</sup> / <sub>4</sub>	14	9 <sup>13</sup> / <sub>16</sub>	3 <sup>7</sup> / <sub>16</sub>	2 <sup>1</sup> / <sub>2</sub>	10 <sup>3</sup> / <sub>4</sub>	11 <sup>3</sup> / <sub>16</sub>	10 @ 15.3	48	6 or less 6 <sup>1</sup> / <sub>2</sub> or more	19 <sup>1</sup> / <sub>4</sub> 23 <sup>7</sup> / <sub>8</sub>	3 <sup>1</sup> / <sub>4</sub> + TT	1/2	1 <sup>3</sup> / <sub>4</sub>
50-63	46 <sup>7</sup> / <sub>8</sub>	28 <sup>1</sup> / <sub>8</sub>	2 <sup>1</sup> / <sub>8</sub>	8 <sup>5</sup> / <sub>16</sub>	5 <sup>7</sup> / <sub>8</sub>	18	11 <sup>1</sup> / <sub>4</sub>	4	3	14 <sup>3</sup> / <sub>4</sub>	10 <sup>15</sup> / <sub>16</sub>	12 @ 20.7	48	11 or less 11 <sup>1</sup> / <sub>2</sub> or more	24 <sup>5</sup> / <sub>8</sub> 30	4 <sup>1</sup> / <sub>4</sub> + TT	3/4	2 <sup>1</sup> / <sub>4</sub>
64-110	Not available																	

Rod take-out = (factor) - (TT / 2), for lever in high position.  
 Note: See the size selection chart in the Pipe Hanger Catalog for the "B" dimension.

Load (lbs)	0 800	801 1,500	1,501 2,540	2,541 4,000	4,001 6,100	6,101 9,400	9,401 13,400	13,401 18,300	18,301 24,700
J Rod Size	1/2	5/8	3/4	1	1 <sup>1</sup> / <sub>4</sub>	1 <sup>1</sup> / <sub>2</sub>	1 <sup>3</sup> / <sub>4</sub>	2	2 <sup>1</sup> / <sub>4</sub>

## Fig. 80-V Types A, B and C

Model R, Sizes 84 to 110



**Note:** "B" Dimensions is a function of total travel ("G" + "B" should not be assumed as equal to "C" Dimension)

**Types A, B, and C** sizes 84 through 110, for large loads and long travels, provide for basically the same methods of upper attachment as sizes 10 to 83 shown with Type A, Type B and Type C.

**Notes:** See load travel tables in the Pipe Hanger Catalog for "B" dimension. For weights see page 12 of this submittal.

**FIG. 80-V, TYPES A,B,C SIZES 84 TO 110: DIMENSIONS (IN)**

Hanger Sizes	L	C		D	E		G		H	M	N	P	X	Total Travel TT	Factor		J - Rod		
		Type A & B	Type C		Type A & B	Type C	Type A & B	Type C							Type A	Type B & C	Min Thread Length	Rod Dia.	
																		Min	Max
84-94	78¾	16	15	49¾	4	4½	1½	1	6	24	10½	3	12	9½ or less	45¾	54¾	10	2	3¾
														10 or more	55½	64½	13		
95-110	100	24	23	64	4	4½	7½	7	6	24	11½	3½	13½	14 or less	51⅞	60⅝	12	2½	3¾
														14½ or more	60⅞	69⅝	15		

\*Rod take-out = (factor) - (.75 x TT), for Lever in high position

Note: See the size selection chart in the Pipe Hanger Catalog for the "B" dimension.

Load (lbs)	14,376 18,300	18,301 24,700	24,701 31,000	31,001 39,000	39,001 48,000	48,001 58,000	58,001 69,000	69,001 87,500
J & K-Rods	2	2¼	2½	2¾	3	3¼*	3½*	3¾*
K-Hole	2⅝	2⅝	2⅞	3⅞	3⅞	3⅞	3⅞	4⅞
R	3	3	4	4	4	4½	4½	4½
S	2⅞	3⅞	3⅞	3⅞	3⅞	4⅞	4⅞	4⅞
T (Type B)	¾	¾	1	1	1	1	1½	1¾
T (Type C)							1¼	1¼
W	6	6	8	8	8	9	9	9

\*¾ and larger is furnished with 4 UNC series thread.

## Fig. 80-V and 81-H

Weight Chart (approx) lbs, each

Hanger Sizes	Fig 80-V			Fig 81-H			
	Types A, B, C, D & E		Type G ■	Types A, B, C, D & E		Type F	
	Net	Shipping	Net	Net	Shipping	Net	Shipping
1 to 3	–	–	–	18	20	–	–
4 to 6	–	–	–	21	23	–	–
7 to 9	–	–	–	23	25	–	–
10 to 12	62	67	160	52	57	174	179
13 to 15	65	70	166	55	60	177	182
16 to 18	70	75	176	60	65	182	187
19 to 20	163	171	371	150	158	415	423
21 to 23	165	173	375	152	160	417	425
24 to 26	172	180	389	159	167	424	432
27 to 29	180	188	405	167	175	432	440
30 to 32	187	195	419	174	182	439	447
33 to 34	195	203	435	182	190	447	455
35 to 37	300	312	676	280	292	640	652
38 to 40	315	327	706	295	307	655	667
41 to 43	332	344	740	312	324	672	684
44 to 46	343	355	762	323	335	683	695
47 to 49	360	372	796	340	352	700	712
50 to 51	601	661	1,278	511	571	1,181	1,241
52 to 54	626	686	1,328	536	596	1,206	1,266
55 to 57	665	725	1,406	575	635	1,245	1,305
58 to 60	706	766	1,488	616	676	1,286	1,346
61 to 63	745	805	1,566	655	715	1,325	1,385
64 to 65	1,468	1,568	–	1,225	1,325	–	–
66 to 68	1,568	1,668	–	1,325	1,425	–	–
69 to 71	1,653	1,753	–	1,410	1,510	–	–
72 to 74	1,753	1,853	–	1,520	1,620	–	–
75 to 77	2,360	2,460	–	1,970	2,070	–	–
78 to 80	2,430	2,530	–	2,020	2,120	–	–
81 to 83	2,570	2,670	–	2,180	2,280	–	–
84 to 85	2,725	2,845	–	2,310	2,430	–	–
86 to 88	2,870	2,990	–	2,455	2,575	–	–
89 to 90	3,070	3,190	–	2,655	2,775	–	–
91 to 92	3,155	3,275	–	2,740	2,860	–	–
93 to 94	3,255	3,375	–	2,840	2,960	–	–
95 to 98	4,350	4,500	–	3,925	4,075	–	–
99 to 102	4,675	4,825	–	4,250	4,400	–	–
103 to 106	5,300	5,450	–	4,875	5,025	–	–
107 to 110	5,800	5,950	–	5,350	5,500	–	–

■ Based on 3'-0" C - C rod dimension and 8" total travel