



FCB-EX1010/FCB-EX1010P



FCB-EX990D/FCB-EX990DP



FCB-EX490D/FCB-EX490DP



FCB-EX20D/FCB-EX20DP



FCB-EX11D/FCB-EX11DP



FCB-EX1000/FCB-EX1000P



FCB-EX980S/FCB-EX980SP
FCB-EX980/FCB-EX980P



FCB-EX480C/FCB-EX480CP



FCB-EX48C/FCB-EX48CP

FCB-EX Series

Color Block Cameras

INTRODUCTION

Sony's FCB Series of color block cameras offers excellent picture quality, superb flexibility, and easy operation in a variety of applications ranging from surveillance to traffic monitoring, and in many other visual communication environments. These cameras are specifically designed to be integrated into security domes, police vehicles, inspection, document stands, and low-vision systems. There are ten cameras in the FCB-EX Series lineup, and each incorporates a wide variety of optical zoom lenses ranging from 10x to 36x. With this breadth of choice, it's never been easier to select the right camera for your specific monitoring applications.

Optical zoom lens	36x	26x	18x	10x
FCB-EX Series Cameras	FCB-EX1010/FCB-EX1010P	FCB-EX990D/FCB-EX990DP	FCB-EX490D/FCB-EX490DP	FCB-EX20D/FCB-EX20DP
	FCB-EX1000/FCB-EX1000P	FCB-EX980S/FCB-EX980SP	FCB-EX480C/FCB-EX480CP	FCB-EX11D/FCB-EX11DP
		FCB-EX980/FCB-EX980P	FCB-EX48C/FCB-EX48CP	

Comparison chart of FCB-EX D version and C version

There are two versions of FCB-EX Series cameras: D version and C version cameras. The different models vary mainly according to Wide-D technology and High Resolution mode.

	D version		C version	
	Yes	No	No	
Wide-D	FCB-EX1010/FCB-EX1010P FCB-EX990D/FCB-EX990DP FCB-EX490D/FCB-EX490DP	FCB-EX20D/FCB-EX20DP FCB-EX11D/FCB-EX11DP	FCB-EX1000/FCB-EX1000P FCB-EX980S/FCB-EX980SP FCB-EX980/FCB-EX980P	FCB-EX480C/FCB-EX480CP FCB-EX48C/FCB-EX48CP
High Resolution	530 TV Lines		470 TV Lines	

FEATURES

Wide Dynamic Range Technology

FCB-EX1010/FCB-EX1010P FCB-EX990D/FCB-EX990DP
 FCB-EX490D/FCB-EX490DP

These cameras incorporate an advanced backlight compensation technology that dramatically improves each camera's dynamic range by 128 times when compared to conventional cameras. Thanks to this new technology, users can capture clear images even in extreme high-contrast lighting environments. The cameras capture the same image twice: first with a normal shutter speed, and then with a high shutter speed. The dark areas captured at normal shutter speed and the bright areas captured at high shutter speed are then combined into one image using an advanced DSP LSI, thus clearly reproducing the original scene.

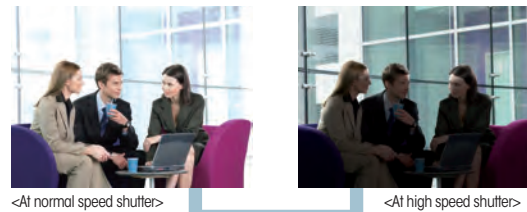

simulated image

High-resolution Images

FCB-EX1010/FCB-EX1010P FCB-EX990D/FCB-EX990DP
FCB-EX490D/FCB-EX490DP FCB-EX20D/FCB-EX20DP
FCB-EX11D/FCB-EX11DP

These cameras combine a Sony original DSP with a 1/4-type EXview HAD CCD® (FCB-EX20D/EX20DP: 1/3-type Super HAD™ CCD II). They achieve a high horizontal resolution of 530 TV lines, enabling reproduction of amazingly clear and detailed images.

High-sensitivity Images

All models

All the cameras in the FCB-EX Series deliver exceptional picture quality thanks to Sony's advanced CCD technology. They provide excellent sensitivity and low smear levels. In particular, the FCB-EX20D/20DP incorporates the newly developed Super HAD CCD II that offers ultra-high sensitivity at 0.25 lx (F1.8, 50IRE).

Auto IR-Cut Filter Removal (Auto ICR)

FCB-EX1010/FCB-EX1010P FCB-EX990D/FCB-EX990DP
FCB-EX490D/FCB-EX490DP FCB-EX20D/FCB-EX20DP
FCB-EX1000/FCB-EX1000P FCB-EX980S/FCB-EX980SP
FCB-EX980/FCB-EX980P FCB-EX480C/FCB-EX480CP

The Auto ICR function incorporated in these cameras offers optimal sensitivity in both day- and night-shooting applications. At a set level of darkness, the IR-cut filter is automatically disabled (ICR ON) and the near-infrared sensitivity is increased. At a set level of brightness, the filter is automatically enabled (ICR OFF). The IR-cut filter automatically engages depending on the ambient light, allowing the camera 24/7 operation in a variety of lighting conditions.

Advanced Spherical Privacy Zone Masking

All models

With these cameras, a maximum of eight masking areas can be displayed on the monitoring screen. Also, if these block cameras are integrated into a Pan/Tilt/Zoom (P/T/Z) camera system, masked areas are interlocked with P/T/Z movement, regardless of the camera angle or camera movement. Up to 24 masking areas can be preset in the entire viewing range of a P/T/Z camera. In addition, FCB-EX Series D version cameras can mask unwanted or prohibited areas within an image using a mosaic effect on top of the color masking function.

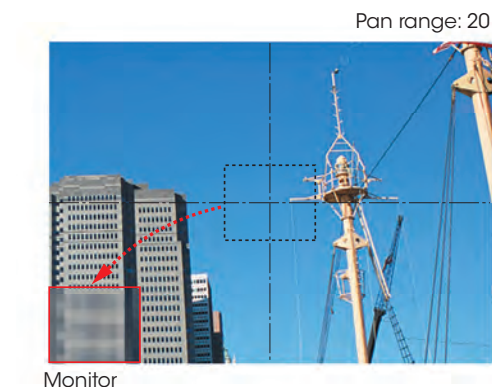

- Masking area
- Movement of masking area

As camera pans and tilts, the masked area moves to maintain the desired covered area.

Electronic Flip (e-Flip)

All models

All the cameras in the FCB-EX Series have an e-Flip function that electronically flips an image upside down so that it is displayed on the monitor accurately. In a dome application, for example, if a tracked object moves beneath the camera dome, the image is inverted to maintain the correct orientation.

Slow AE Response Function

All models

All of the cameras in the FCB-EX Series are equipped with a Slow AE response function to automatically slow the rate at which camera exposure levels change. The rate can be set up to 32 times slower than when Full-auto AE or Priority (shutter/iris) modes are selected. This function is beneficial when monitoring areas in which lighting conditions change abruptly (e.g. underground parking lots, traffic monitoring and control, or police cars).

Image Stabilizer

FCB-EX980S/FCB-EX980SP

The image stabilizer function in these cameras minimizes the appearance of shaky images caused by low-frequency vibration, and maintains a normal horizontal resolution. This function is useful for long-range outdoor surveillance and traffic monitoring applications, to reduce pole or bridge vibration.

Multi-line On-screen Display

FCB-EX1010/FCB-EX1010P FCB-EX990D/FCB-EX990DP
FCB-EX490D/FCB-EX490DP FCB-EX20D/FCB-EX20DP
FCB-EX11D/FCB-EX11DP

With these cameras, up to eleven lines with 20 characters per line can be displayed on the monitoring screen using VISCA commands. Users can freely display captions on the screen such as the monitoring location, camera name, and alarm messages, providing operators with a user-friendly interface.



Video Motion Detection

FCB-EX1010/FCB-EX1010P FCB-EX990D/FCB-EX990DP
FCB-EX490D/FCB-EX490DP FCB-EX20D/FCB-EX20DP
FCB-EX11D/FCB-EX11DP

These cameras incorporate a video motion detection function. When motion is detected within an area of the picture designated by the user, an alarm signal is output via the camera's control interface using the VISCA protocol. Users can designate up to four detecting areas freely from any of eight vertical and twelve horizontal blocks.

Picture Freeze

All models

All of the cameras in the FCB-EX Series are equipped with a Picture Freeze function that allows for the output of a still image while the camera is panning, tilting, zooming, focusing, initializing the lens, or performing preset operations. For example, the camera will output a still image before it begins to pan, tilt, or zoom, and once the operation is completed, the camera continues to display images that are currently being monitored. This way unnecessary images are not displayed.

SMART (Sony Modular Automatic Lens Reset Technology) Lens Control

All models

All of the cameras in the FCB-EX Series feature this function. Each incorporates SMART Lens Control technology, which monitors the focus position of the lens while zooming, and automatically compensates for any mechanical misalignment that may occur over long periods of continuous usage. With this beneficial feature, periodic lens initialization is no longer required during continuous 24-hour operation.

DIMENSIONS

FCB-EX1010/FCB-EX1010P FCB-EX1000/FCB-EX1000P

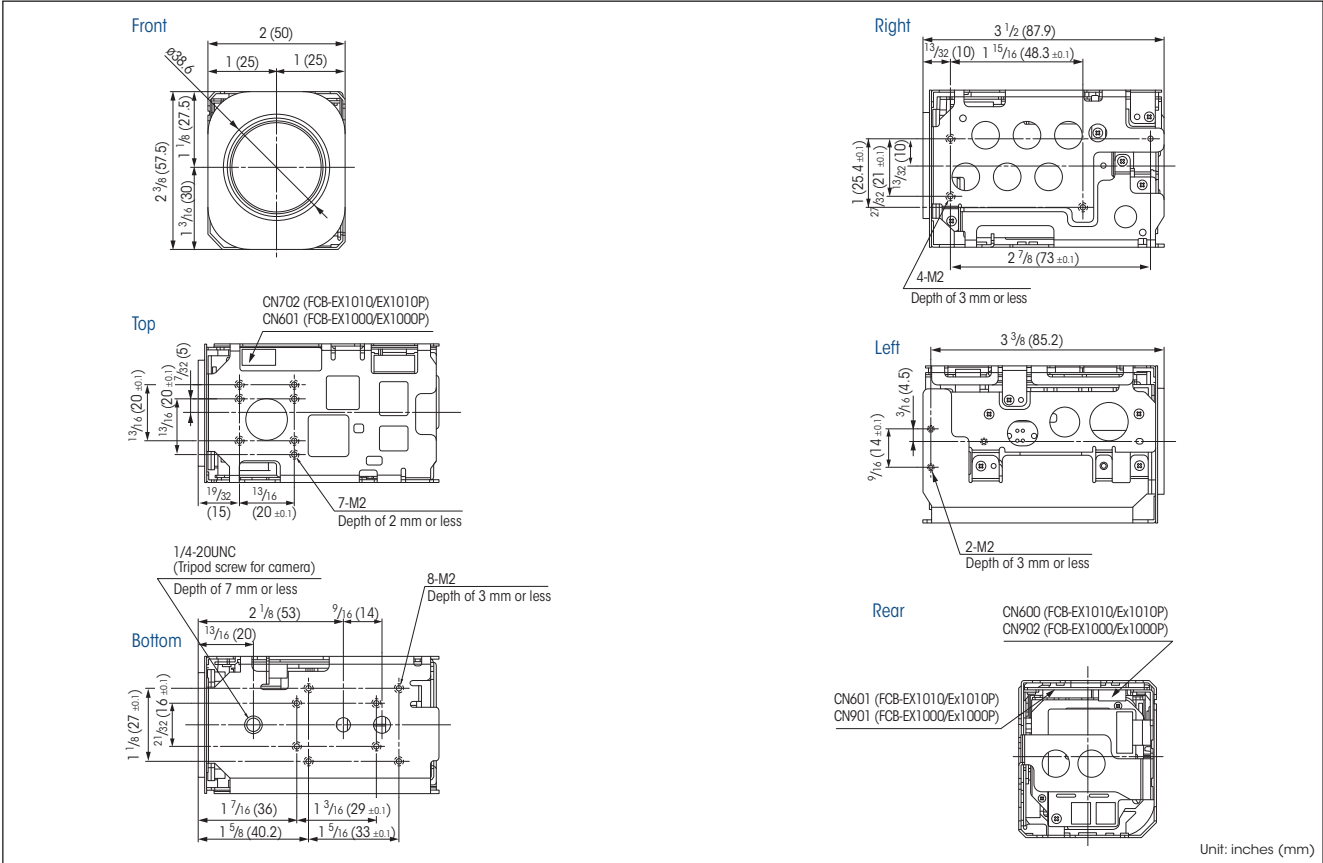

FCB-EX990D/FCB-EX990DP FCB-EX980S/FCB-EX980SP FCB-EX980/FCB-EX980P

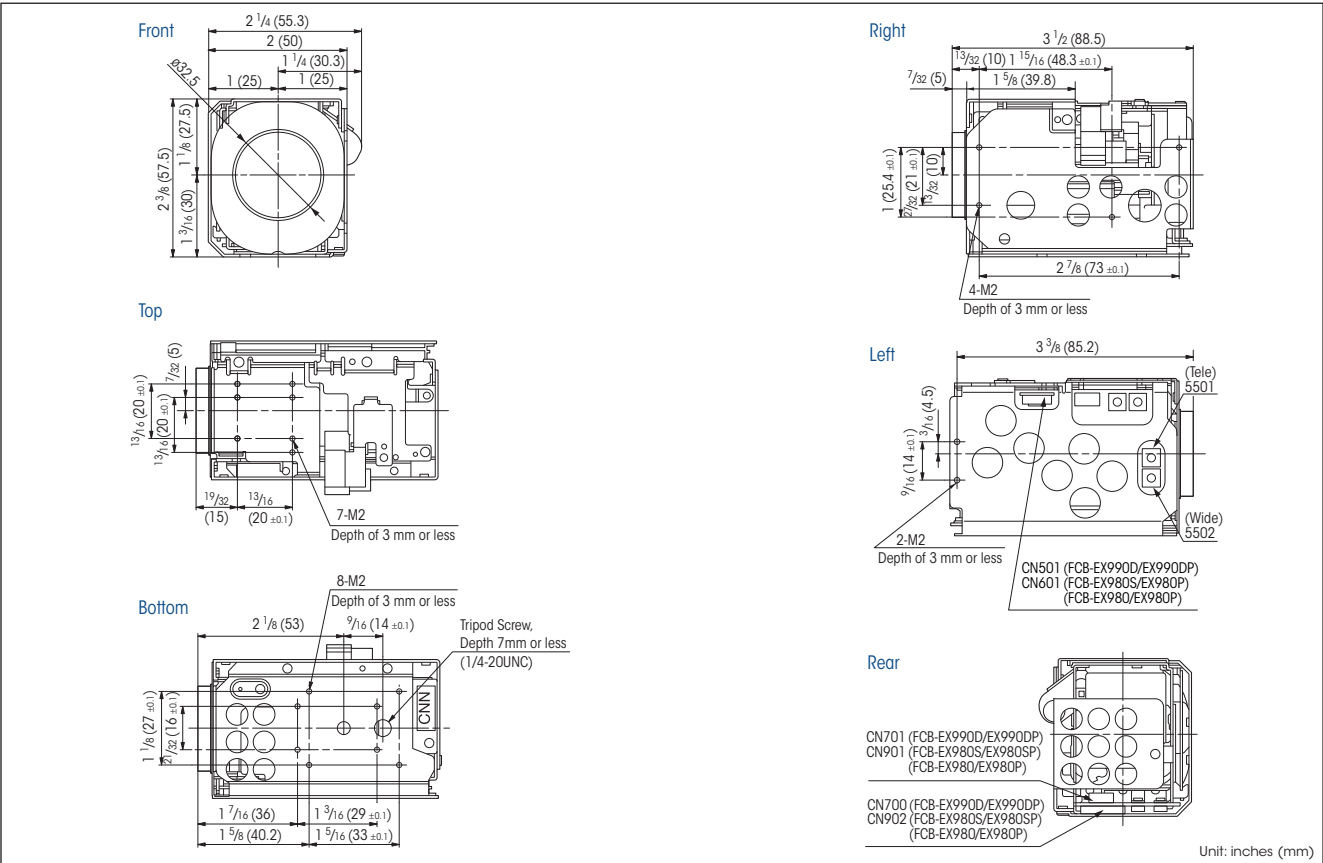

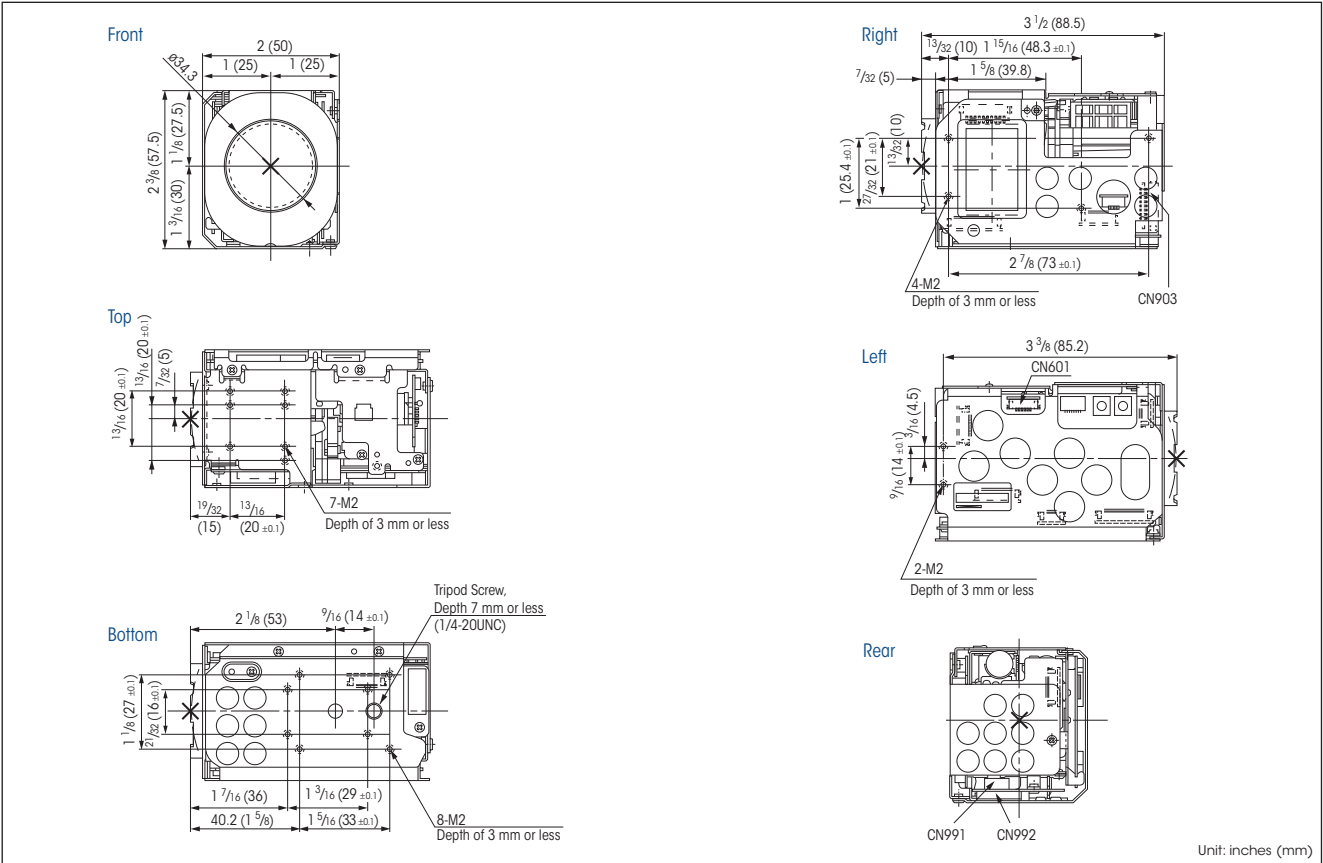
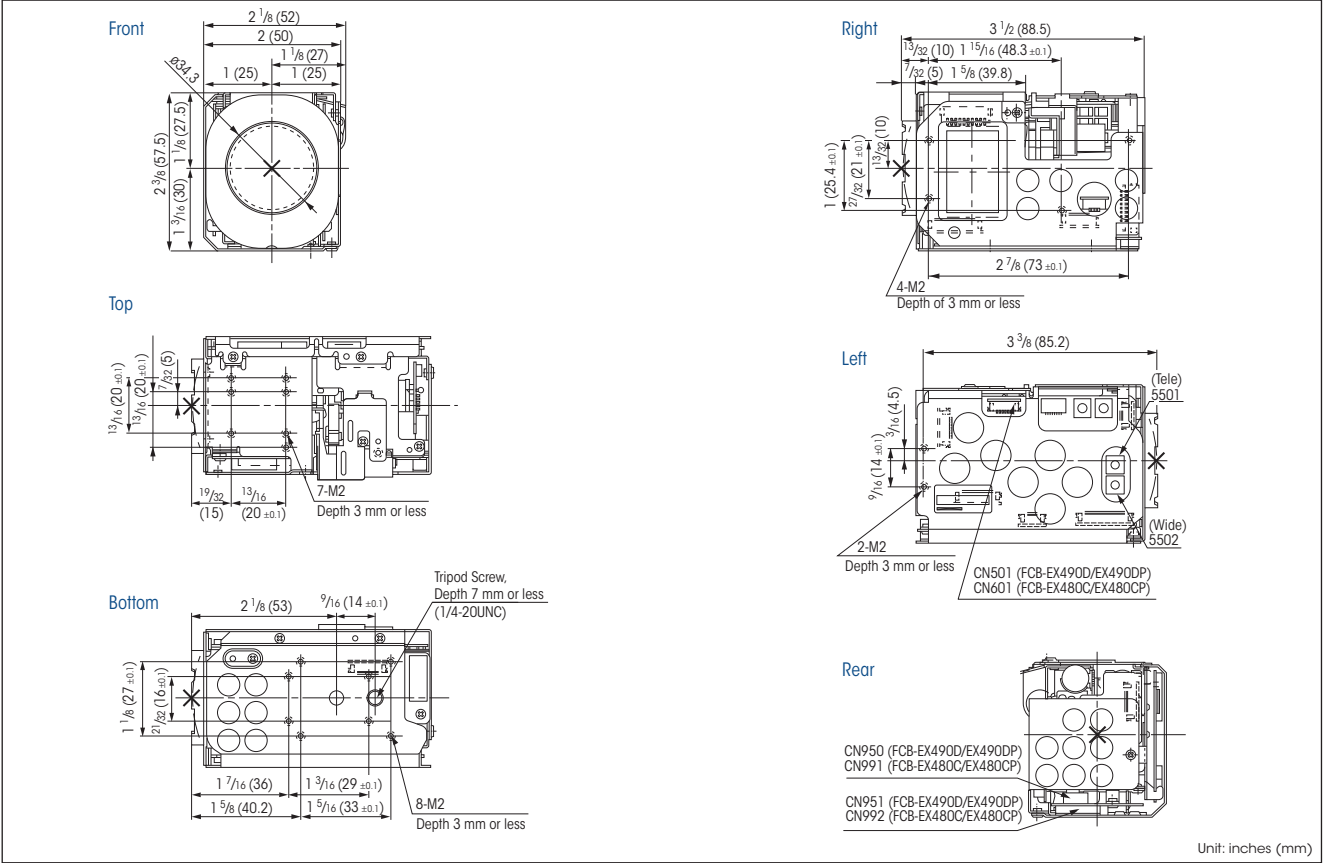

DIMENSIONS

FCB-EX20D/FCB-EX20DP

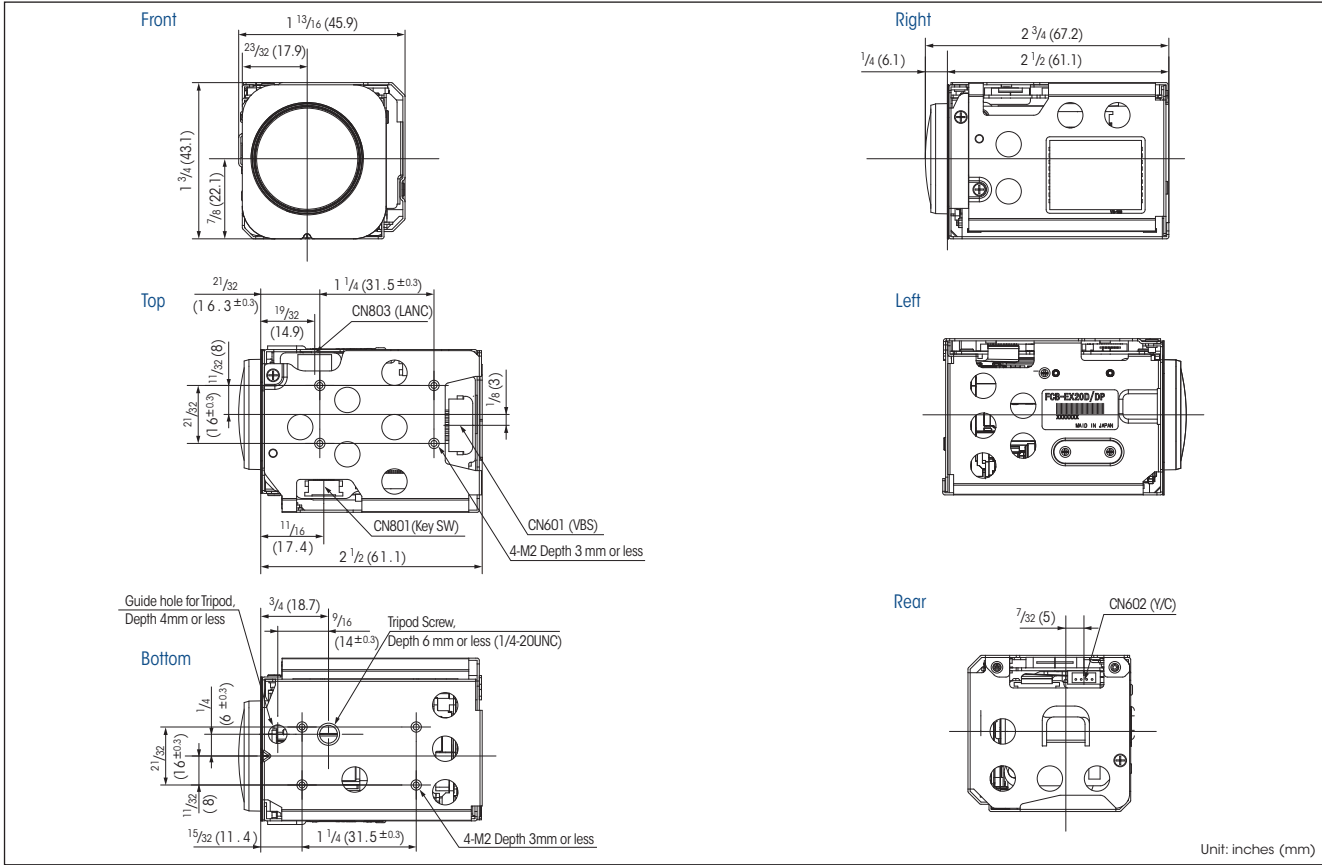

FCB-EX11D/FCB-EX11DP

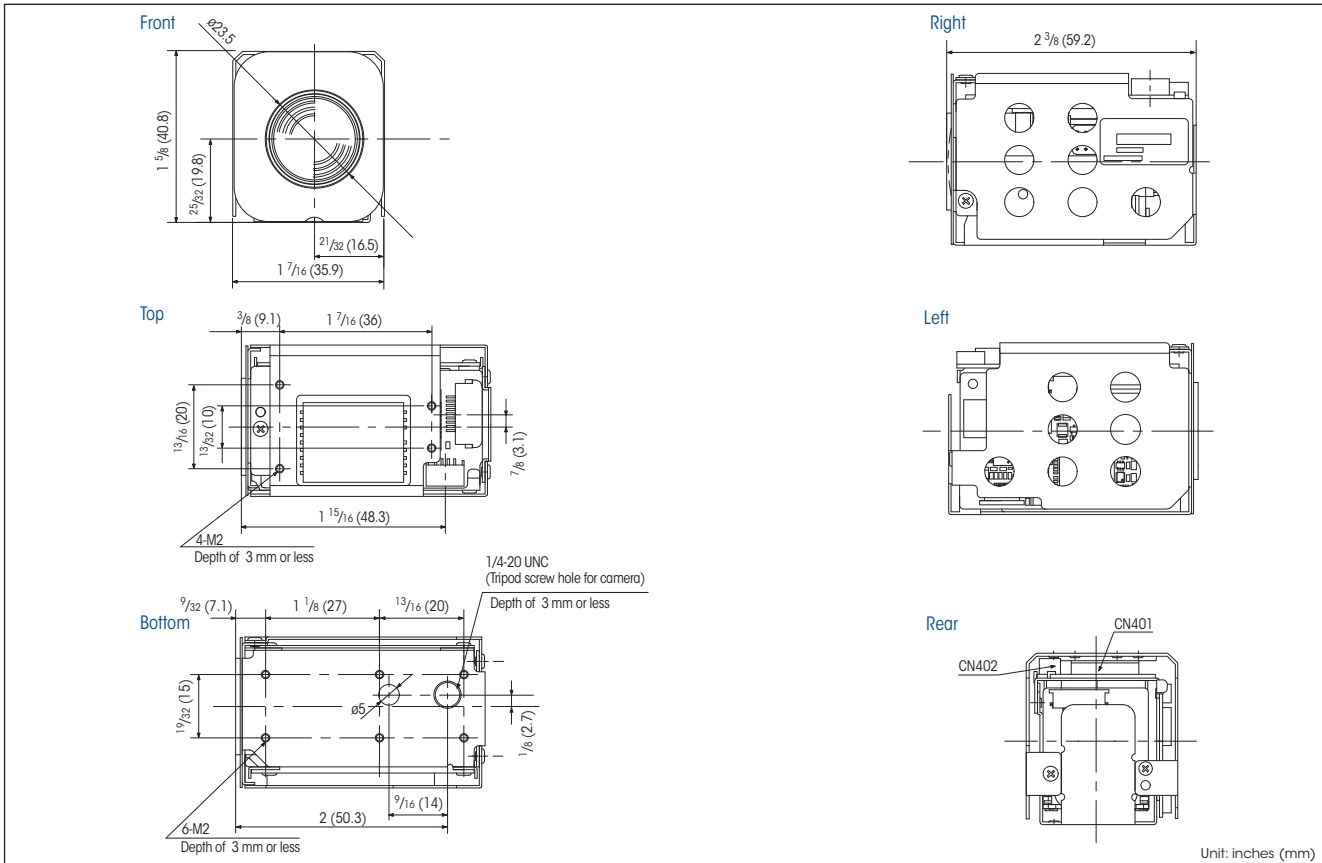

PIN ASSIGNMENT

■ 4-pin for Y/C Video Out

CN600	FCB-EX1010/FCB-EX1010P	CN902	FCB-EX1000/FCB-EX1000P
CN700	FCB-EX990D/FCB-EX990DP		FCB-EX980S/FCB-EX980SP
CN950	FCB-EX490D/FCB-EX490DP		FCB-EX980/FCB-EX980P
CN602	FCB-EX20D/FCB-EX20DP	CN991	FCB-EX480C/FCB-EX480CP
CN402	FCB-EX11D/FCB-EX11DP		FCB-EX48C/FCB-EX48CP

Pin No.	Name	Level
1	Y_OUT	1.0 Vp-p (75 Ω terminate) Luminance signal
2	GND (for Y signal)	-
3	C_OUT	Chrominance signal
4	GND (for C signal)	-

Connector: JST S4B-ZR-SM4A-TF (LF)

■ 9-pin for DC/Video Out

CN601	FCB-EX1010/FCB-EX1010P	CN901	FCB-EX1000/FCB-EX1000P
CN701	FCB-EX990D/FCB-EX990DP		FCB-EX980S/FCB-EX980SP
CN951	FCB-EX490D/FCB-EX490DP		FCB-EX980/FCB-EX980P
CN601	FCB-EX20D/FCB-EX20DP	CN992	FCB-EX480C/FCB-EX480CP
CN401	FCB-EX11D/FCB-EX11DP		FCB-EX48C/FCB-EX48CP

Pin No.	Name	Level
1	RxD	TTL/CMOS Level Read Data
2	TxD	TTL/CMOS Level Send Data
3	GND (for RxD & TxD)	-
4	DC IN	9.0 V ±3.0 V
5	GND (for DC IN)	-
6	VBS OUT	1.0 Vp-p (75 Ω terminate)
7	GND (for VBS OUT)	-
8	V LOCK PULSE	External VD-Lock Pulse (Negative, 3.0 Vp-p 50% duty)
9	GND (for V LOCK PULSE)	-

Connector: KYOCERA ELCO 00 6200 509 130 000+

■ 9-pin for DC IN/VBS Y/C Out connector

CN903	FCB-EX480C/FCB-EX480CP
	FCB-EX48C/FCB-EX48CP

Pin No.	Name	Level
1	DC IN	9.0 V ±3 V
2	GND (for DC IN)	
3	NC	
4	VBS OUT	1.0 V ±0.2 V
5	GND (for VBS OUT)	
6	Y Out	1.0 V ±0.2 V
7	GND (for Y signal)	
8	C Out	
9	GND (for C signal)	

J.S.T.Mfg Co. S9B-ZR-SM4A-TF (LF)

■ 12-pin for Key Switch Control

CN702	FCB-EX1010/FCB-EX1010P	CN601	FCB-EX1000/FCB-EX1000P
CN501	FCB-EX990D/FCB-EX990DP		FCB-EX980S/FCB-EX980SP
	FCB-EX490D/FCB-EX490DP		FCB-EX980/FCB-EX980P
CN801	FCB-EX20D/FCB-EX20DP		FCB-EX480C/FCB-EX480CP
			FCB-EX48C/FCB-EX48CP

Pin No.	Name	Level
1	GND	-
2	GND	-
3	KEY_AD0	Pull up to 3.0 V by 100 kΩ
4	KEY_AD1	Pull up to 3.0 V by 100 kΩ
5	KEY_AD2	Pull up to 3.0 V by 100 kΩ
6	KEY_AD3	Pull up to 3.0 V by 100 kΩ
7	KEY_AD4	Pull up to 3.0 V by 100 kΩ
8	KEY_AD5	Pull up to 3.0 V by 100 kΩ
9	KEY_AD6	Pull up to 3.0 V by 100 kΩ
10	KEY_AD7	Pull up to 3.0 V by 100 kΩ
11	NC	-
12	Strobe	Strobe firing pulse (0 to 3.0 V)

Connector: KYOCERA ELCO 08 6222 012 101 848+

SPECIFICATIONS

■ FCB-EX Series D Version

	FCB-EX1010	FCB-EX1010P	FCB-EX990D	FCB-EX990DP	FCB-EX490D	FCB-EX490DP	FCB-EX20D	FCB-EX20DP	FCB-EX11D	FCB-EX11DP
Image sensor	1/4-type EXview HAD CCD		1/4-type EXview HAD CCD		1/4-type EXview HAD CCD		1/3-type Super HAD CCD II		1/4-type EXview HAD CCD	
Signal system	NTSC	PAL	NTSC	PAL	NTSC	PAL	NTSC	PAL	NTSC	PAL
Effective picture elements	Approx. 380,000 pixels	Approx. 440,000 pixels	Approx. 380,000 pixels	Approx. 440,000 pixels	Approx. 380,000 pixels	Approx. 440,000 pixels	Approx. 380,000 pixels	Approx. 440,000 pixels	Approx. 380,000 pixels	Approx. 440,000 pixels
Horizontal resolution	High Resolution Mode On: 530 TV lines (default) High Resolution Mode Off: 470 TV lines (NTSC)/460 TV lines (PAL)									
Lens	36x optical zoom, f=3.4 mm (wide) to 122.4 mm (tele), F1.6 to F4.5		26x optical zoom, f=3.5 mm (wide) to 91.0 mm (tele), F1.6 to F3.8		18x optical zoom, f=4.1 mm (wide) to 73.8 mm (tele), F1.4 to F3.0		10x optical zoom, f=5.1 mm (wide) to 51.0 mm (tele), F1.8 to F2.1		10x optical zoom, F1.8 to F2.9, f=4.2 mm (wide) to 42.0 (tele)	
Digital zoom	12x (432x with optical zoom)		12x (312x with optical zoom)		12x (216 x with optical zoom)		12x (120x with optical zoom)			
Horizontal angle of view	57.8°(wide) to 1.7° (tele)		54.2°(wide) to 2.2°(tele)		48.0°(wide) to 2.8° (tele)		52.0°(wide) to 5.4° (tele)		46.0° (wide) to 4.6° (tele)	
TV distortion	-						4.5%		-	
Minimum object distance	320 mm (wide) to 1500 mm (tele)				290 mm (wide) to 800 mm (tele)		15 mm (wide) to 800 mm (tele)		200 mm (wide) to 1.0 m (tele)	
Sync system	Internal/External (V-Lock)									
Minimum illumination	1/60 s mode: 1.4 lx (typical) (F1.6, 50 IRE) 1/4 s mode: 0.1 lx (typical) (F1.6, 50 IRE)		1/60 s mode: 1.0 lx (typical) (F1.6, 50 IRE) 1/4 s mode: 0.09 lx (typical) (F1.6, 50 IRE)		1/60 s mode: 0.7 lx (typical) (F1.4, 50 IRE) 1/4 s mode: 0.07 lx (typical) (F1.4, 50 IRE)		1/60 s, 1/50 s mode: 0.25 lx (typical) (F1.8, 50 IRE) 1/4 s, 1/3 s mode: 0.015 lx (typical) (F1.8, 50 IRE) 1/4 s, 1/3 s mode & ICR On: 0.0004 lx (typical) (F1.8, 50 IRE)		1.0 lx (typical) (F1.8, 50 IRE)	
Auto ICR	Yes								No	
Image stabilizer	No									
Video motion detection	Yes									
Multi-line OSD	Yes (Up to eleven lines with 20 characters per line)									
Slow AE response	Yes									
E-flip	Yes									
Picture freeze	Yes									
Slow shutter	Yes									
Video output	VBS: 1.0 Vp-p (sync negative), Y/C									
Camera control interface	VISCA (TTL signal level), baud rate: 9.6 kb/s, 19.2 kb/s, 38.4 kb/s, 1 or 2 stop-bit selectable									
S/N ratio	More than 50 dB									
Electronic shutter	1/1 to 1/10,000 s, 22 steps									
White balance	AUTO, ATW, Indoor, Outdoor, One-push, Manual									
Gain	Auto/Manual (-3 to 28 dB, 2 dB steps)									
AE control	Auto, Manual, Priority mode (shutter priority & iris priority), Bright, EV compensation, Back light compensation, Slow AE									
Wide dynamic range	(On/Off)						No			
Backlight compensation	(On/Off)									
Privacy zone masking	Yes (On/Off) (8 masks per view/24 masks preset in the entire viewing range when integrated into a PTZ camera- 14 colors, mosaic)									
Character generator	Mode display/Multi-line OSD (OSD has priority over Mode display)									
Flicker cancel	(Auto)	-	(Auto)	-	(Auto)	-	(Auto)	-	(Auto)	-
Focusing system	Auto (Sensitivity: normal, low), One-push AF, Manual, Infinity, Interval AF, Zoom Trigger AF									
Picture effects	E-flip, Nega Art, Black & White, Mirror Image									
Zoom switch	Tele, Wide									
Storage temperature	-4 to 140 °F (-20 to 60 °C)									
Operating temperature	32 to 122 °F (0 to 50 °C)									
Power requirements	DC 6 to 12 V									
Power consumption	2.6 W (motors inactive), 4.9 W (motors active)		2.6 W (motors inactive), 5.4 W (motors active)		2.6 W (motors inactive), 4.4 W (motors active)		2.8W (motors inactive), 6.5 W (motors active)		1.9 W (motors inactive), 2.8 W (motors active)	
Weight	8.1 oz (230 g)				5 oz (140 g)			3.3 oz (95 g)		
Dimensions	2 x 2 3/8 x 3 1/2 inches (50.0 x 57.5 x 87.9 mm)		55.3 x 57.5 x 88.5 mm (2 x 2 3/8 x 3 1/2 inches)		2 1/8 x 2 3/8 x 3 1/2 inches (52.0 x 57.5 x 88.5 mm)		1 13/16 x 1 3/4 x 2 3/4 inches (45.9 x 43.1 x 67.2 mm)		1 7/16 x 1 5/8 x 2 3/8 inches (35.9 mm x 40.8 mm x 59.2 mm)	

SPECIFICATIONS

■ FCB-EX Series C Version

	FCB-EX1000	FCB-EX1000P	FCB-EX980S	FCB-EX980SP	FCB-EX980	FCB-EX980P	FCB-EX480C	FCB-EX480CP	FCB-EX48C	FCB-EX48CP
Image sensor	1/4-type EXview HAD CCD		1/4-type Super HAD CCD		1/4-type EXview HAD CCD		1/4-type EXview HAD CCD		1/4-type EXview HAD CCD	
Signal system	NTSC	PAL	NTSC	PAL	NTSC	PAL	NTSC	PAL	NTSC	PAL
Effective picture elements	Approx. 380,000 pixels	Approx. 440,000 pixels	Approx. 680,000 pixels	Approx. 800,000 pixels	Approx. 380,000 pixels	Approx. 440,000 pixels	Approx. 380,000 pixels	Approx. 440,000 pixels	Approx. 380,000 pixels	Approx. 440,000 pixels
Horizontal resolution	470 TV lines	460 TV lines	470 TV lines	460 TV lines	470 TV lines	460 TV lines	470 TV lines	460 TV lines	470 TV lines	460 TV lines
Lens	36x optical zoom, f=3.4 mm (wide) to 122.4 mm (tele), F1.6 to F4.5		26 x optical zoom, f=3.5 mm (wide) to 91.0 mm (tele), F1.6 to F3.8				18 x optical zoom, f=4.1 mm (wide) to 73.8 mm (tele), F1.4 to F3.0			
Digital zoom	12x (432x with optical zoom)		12x (312x with optical zoom)				12 x (216 x with optical zoom)			
Horizontal angle of view	57.8°(wide) to 1.7° (tele)		42.2° (wide) to 1.6°(tele)		54.2° (wide) to 2.2° (tele)		48.0°(wide) to 2.8°(tele)			
Minimum object distance	320 mm (wide) to 1500 mm (tele)		35 mm (wide) to 800 mm (tele)							
Sync system	Internal/External (V-Lock)									
Minimum illumination	1/60 s mode: 1.4 lx (typical) (F1.6, 50 IRE) 1/4 s mode: 0.1 lx (typical) (F1.6, 50 IRE)		2.0 lx (typical) (F1.6, 50 IRE)		1.0 lx (typical) (F1.6, 50 IRE)		0.7 lx (typical) (F1.4, 50 IRE)			
Auto ICR	Yes								No	
Image stabilizer	No		Yes		No					
Video motion detection	No				No					
Multi-line OSD	No									
Slow AE response	Yes		No							
E-flip	Yes									
Picture freeze	Yes									
Slow shutter	Yes									
Video output	VBS: 1.0 Vp-p (sync negative), Y/C									
Camera control interface	VISCA (TTL signal level), baud rate: 9.6 kb/s, 19.2 kb/s, 38.4 kb/s, 1 or 2 stop-bit selectable									
S/N ratio	More than 50 dB (weight ON)									
Electronic shutter	1/1 to 1/10,000 s, 22 steps									
White balance	AUTO, ATW, Indoor, Outdoor, One-push, Manual									
Gain	Auto/Manual (-3 to 28 dB, 2 dB steps)									
AE control	Auto, Manual, Priority mode (shutter priority & iris priority), Bright, EV compensation, Backlight compensation, Slow AE									
Wide dynamic range	No									
Backlight compensation	(On/Off)									
Privacy zone masking	On/Off (24 positions) (without mosaic effects)									
Character generator	Mode display									
Flicker cancel	(Auto)	-	(Auto)	-	(Auto)	-	(Auto)	-	(Auto)	-
Focusing system	Auto (Sensitivity: normal, low), One-push AF, Manual, Infinity, Interval AF, Zoom Trigger AF									
Picture effects	e-Flip, Nega Art, Black & White, Mirror Image									
Zoom switch	Tele/Wide									
Storage temperature	-4 to 140°F (-20 to 60 °C)									
Operating temperature	32 to 122°F (0 to 50 °C)									
Power requirements	6 to 12 V									
Power consumption	1.6 W (motor inactive), 4.0 W (motors active)		1.6 W (motors inactive), 3.3 W (motors active)				1.6 W (motors inactive), 2.5 W (motors active)			
Weight	230 g (8.1 oz)									
Dimensions	2 x 2 3/8 x 3 1/2 inches (60.0 x 57.5 x 87.9 mm)		2 1/4 x 2 3/8 x 3 1/2 inches (55.3 x 57.5 x 88.5 mm)				2 1/8 x 2 3/8 x 3 1/2 inches (52.0 x 57.5 x 88.5 mm)			

SONY

Sony Electronics Inc.
1 Sony Drive
Park Ridge, NJ 07656
www.sony.com/videocameras

IS-1215 (MK10535V1)

© 2008 Sony Electronics Inc. All rights reserved.
Reproduction in whole or in part without written permission is prohibited.
Design, features, and specifications are subject to change without notice.
All non-metric weights and measurements are approximate.
Sony is a registered trademark of Sony Corporation.
Sony, EXView HAD CCD, and Super HAD are registered trademarks of Sony Electronics.

Printed in USA (1/09)