

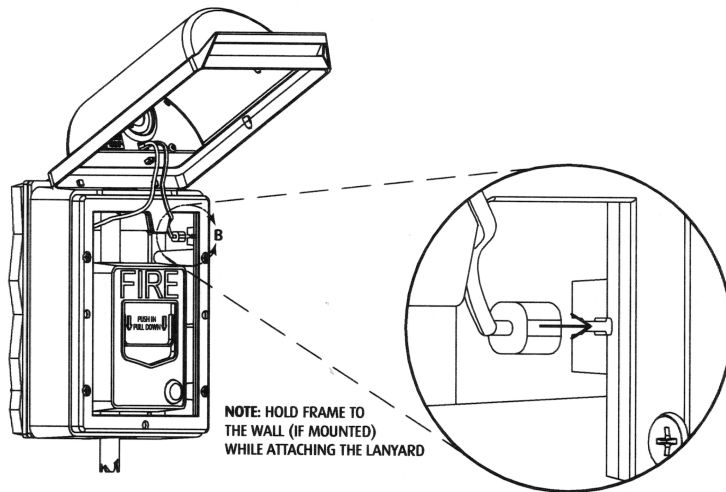

Safety Technology International, Inc.
 2306 Airport Road • Waterford, Michigan 48327-1209
 Phone: 248-673-9898 • Fax: 248-673-1246
 Toll Free: 800-888-4784 • E-mail: info@sti-usa.com
 Web: www.sti-usa.com

Safety Technology International Ltd
 Taylor House • 34 Sherwood Road • Bromsgrove
 Worcestershire • B60 3DR • England
 Tel: +44 (0)1527 520 999 • Fax: +44 (0)1527 501 999
 E-mail: info@sti-europe.com • Web: www.sti-europe.com

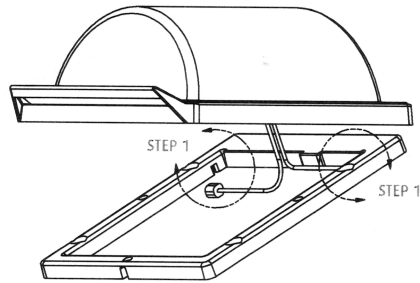

NOTE: HOLD FRAME TO THE WALL (IF MOUNTED) WHILE ATTACHING THE LANYARD

DETAIL B

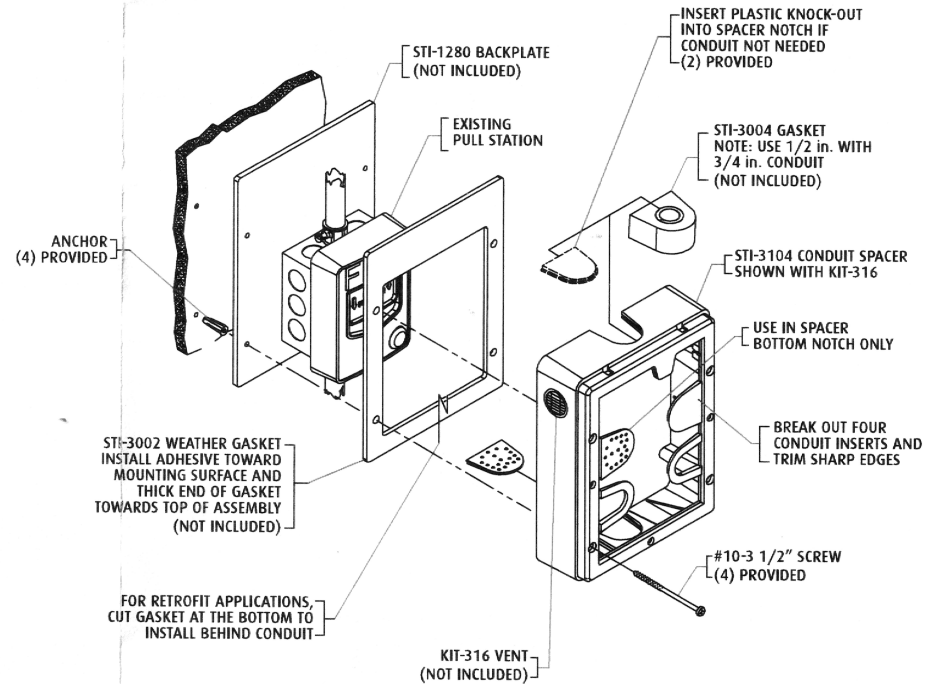

INSTALLATION NOTES

1. To remove cables from existing frame, grab and rock the ends out of position. Frame is not required with STI-3100 spacer.
2. Mount STI-3100 spacer. Mark and drill holes as follows:
 - a. Wall anchors: drill four 1/4" (6.3mm) 1-1/4" deep
 - b. No wall anchors: drill four 5/32" (3.9mm) 1-1/4" deep
3. Install cover by pressing cable end stop into spacer.

Three year warranty or a one year limited warranty (from date of purchase) on most products. See website for details. Electronic warranty form at www.sti-usa.com/wc14.



INSTALLATION OF STI-3100 CONDUIT SPACER

All specifications and information shown were current as of publication and are subject to change without notice.