

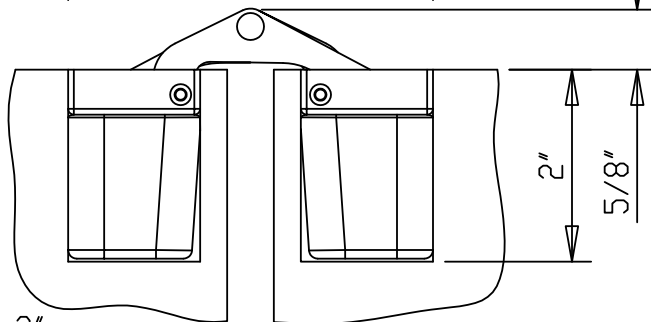

HINGE OPEN 180°  
ISOMETRIC VIEW

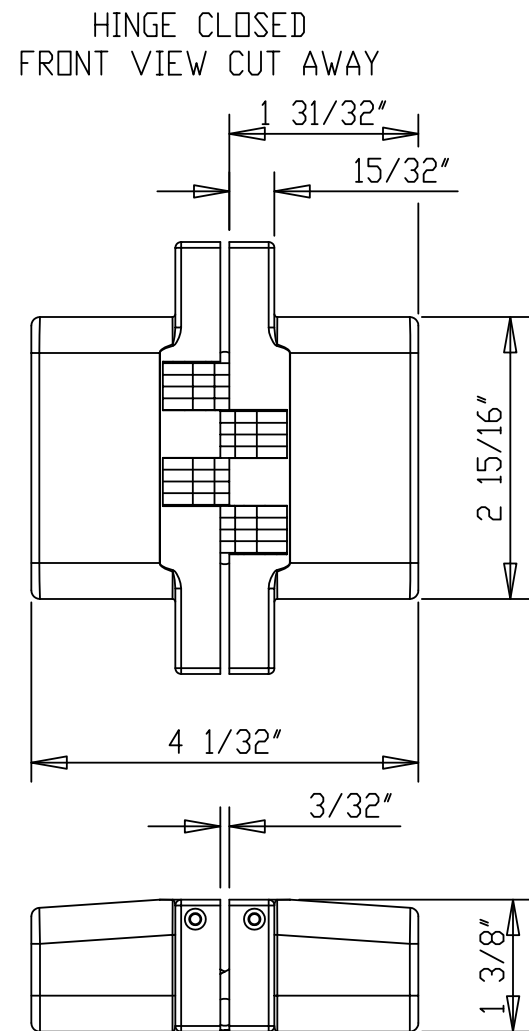
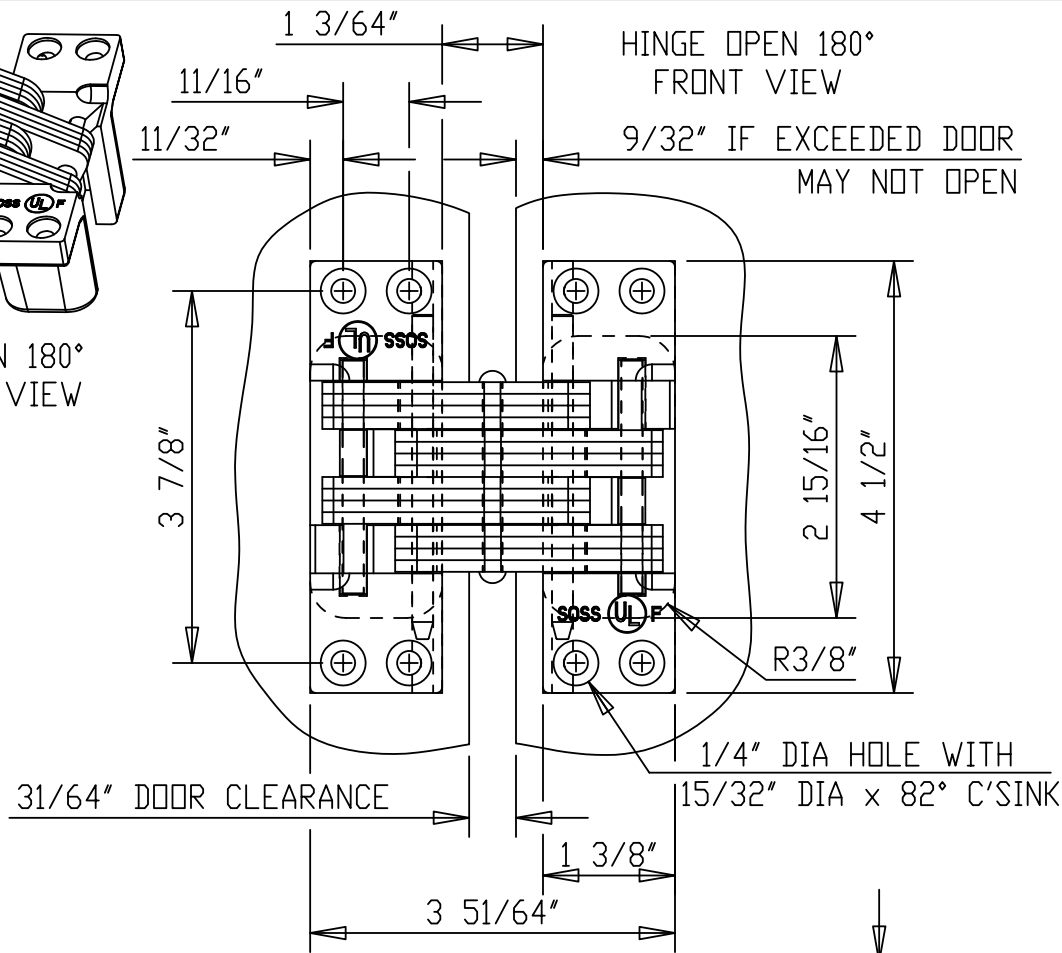

SUPPLIED:  
MACH. SCREW  
#12-24 x 1"

MIN. MATERIAL THICKNESS IS 2"  
DO NOT SCALE DRAWING  
ALL DIMENSIONS ARE IN INCH  
DOOR CLEARANCE REDUCES TO 1/64" WHILE CLOSING  
SEE DWG# 4477-C IF ADDING MATERIAL TO DOOR FACE AND/OR FRAME FACE

HINGE CLOSED  
TOP VIEW CUT AWAY

 ©Copyright 2008 Universal Industrial Products, Inc. One Coreway Drive Pioneer, Ohio 43554-0628	SCALE: 1/2 = 1
	DRAWN BY: LHH
HINGE TEMPLATE	DATE: 5/01/11
SSOS INVISIBLE HINGE 420/420SS 3 HOUR FR	DRAWING # 420