

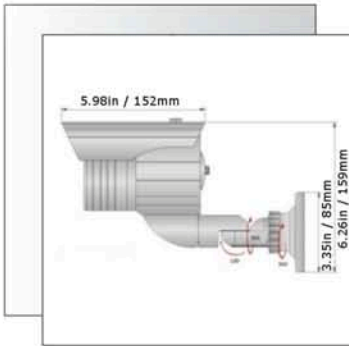

## Mini-Line Tracklight Housing with IR LEDs

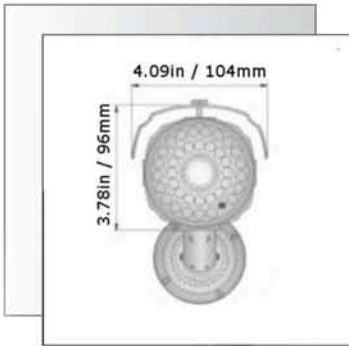

MLTL-2DN49IR  
MLTL-2DN922IR

## IMPORTANT SAFEGUARDS

1. Read Instructions - All the safety and operating instructions should be read before the unit is operated.
2. Retain Instructions - The safety and operating instructions should be retained for future reference.
3. Heed Warnings - All warnings on the unit and in the operating instructions should be adhered to.
4. Follow Instructions - All operating and use instructions should be followed.
5. Cleaning - Unplug the unit from the outlet before cleaning. Do not use liquid cleaners or aerosol cleaners. Use a damp cloth for cleaning.
6. Attachments - Do not use attachments not recommended by the product manufacturer as they may cause hazards.
7. Accessories - Do not place this unit on an unstable stand, tripod, bracket, or mount. The unit may fall, causing serious injury to a person and serious damage to the unit. Use only with a stand, tripod, bracket, or mount recommended by the manufacturer, or sold with the product. Any mounting of the unit should follow the manufacturer's instructions, and should use a mounting accessory recommended by the manufacturer.  
 An appliance and cart combination should be moved with care. Quick stops, excessive force, and uneven surfaces may cause the appliance and cart combination to overturn.
8. Ventilation - Openings in the enclosure, if any, are provided for ventilation and to ensure reliable operation of the unit and to protect it from overheating. These openings must not be blocked or covered. This unit should not be placed in a built-in installation unless proper ventilation is provided or the manufacturer's instructions have been adhered to.
9. Power Sources - This unit should be operated only from the type of power source indicated on the marking label. If you are not sure of the type of power supply you plan to use, consult your appliance dealer or local power company. For units intended to operate from battery power, or other sources, refer to the operating instructions.
10. Grounding or Polarization - This unit may be equipped with a polarized alternating-current line plug (a plug having one blade wider than the other). This plug will fit into the power outlet only one way. This is a safety feature. If you are unable to insert the plug fully into the outlet, try reversing the plug. If the plug should still fail to fit, contact your electrician to replace your obsolete outlet. Do not defeat the safety purpose of the polarized plug.  
Alternately, this unit may be equipped with a 3-wire grounding-type plug, a plug having a third (grounding) pin. This plug will only fit into a grounding-type power outlet. This is a safety feature. If you are unable to insert the plug into the outlet, contact your electrician to replace your obsolete outlet. Do not defeat the safety purpose of the grounding-type plug.
11. Power-Cord Protection - Power-supply cords should be routed so that they are not likely to be walked on or pinched by items placed upon or against them, paying particular attention to cords and plugs, convenience receptacles, and the point where they exit from the appliance.
12. Power Lines - An outdoor system should not be located in the vicinity of overhead power lines or other electric light or power circuits, or where it can fall into such power lines or circuits. When installing an outdoor system, extreme care should be taken to keep from touching such power lines or circuits as contact with them might be fatal. U.S.A. models only - refer to the National Electrical Code Article 820 regarding installation of CATV systems.
13. Overloading - Do not overload outlets and extension cords as this can result in a risk of fire or electric shock.
14. Object and Liquid Entry - Never push objects of any kind into this unit through openings as they may touch dangerous voltage points or short-out parts that could result in a fire or electric shock. Never spill liquid of any kind on the unit.
15. Servicing - Do not attempt to service this unit yourself as opening or removing covers may expose you to dangerous voltage or other hazards. Refer all servicing to qualified service personnel.
16. Damage Requiring Service - Unplug the unit from the outlet and refer servicing to qualified service personnel under the following conditions:
  - a. When the power-supply cord or plug is damaged.
  - b. If liquid has been spilled, or objects have fallen into the unit.
  - c. If the unit has been exposed to rain or water.
  - d. If the unit does not operate normally by following the operating instructions. Adjust only those controls that are covered by the operating instructions, as an improper adjustment of other controls may result in damage and will often require extensive work by a qualified technician to restore the unit to its normal operation.
  - e. If the unit has been dropped or the cabinet has been damaged.
  - f. When the unit exhibits a distinct change in performance--this indicates a need for service.
17. Replacement Parts - When replacement parts are required, be sure the service technician has used replacement parts specified by the manufacturer or have the same characteristics as the original part. Unauthorized substitutions may result in fire, electric shock or other hazards.
18. Safety Check - Upon completion of any service or repairs to this unit, ask the service technician to perform safety checks to determine that the unit is in proper operating condition.
19. Coax Grounding - If an outside cable system is connected to the unit, be sure the cable system is grounded. U.S.A. models only--Section 810 of the National Electrical Code, ANSI/NFPA No.70-1981, provides information with respect to proper grounding of the mount and supporting structure, grounding of the coax to a discharge unit, size of grounding conductors, location of discharge unit, connection to grounding electrodes, and requirements for the grounding electrode.
20. Lightning - For added protection of this unit during a lightning storm, or when it is left unattended and unused for long periods of time, unplug it from the wall outlet and disconnect the cable system. This will prevent damage to the unit due to lightning and power-line surges.



## FCC & ICES INFORMATION (U.S.A. and Canadian Models Only)

**WARNING** - This equipment has been tested and found to comply with the limits for a Class A digital device, pursuant to Part 15 of the FCC Rules and ICES-003 of Industry Canada. These limits are designed to provide reasonable protection against harmful interference when the equipment is operated in a commercial environment. This equipment generates, uses, and can radiate radio frequency energy and, if not installed and used in accordance with the instruction manual, may cause harmful interference to radio communications. Operation of this equipment in a residential area is likely to cause harmful interference in which case the user will be required to correct the interference at his own expense. Intentional or unintentional changes or modifications not expressly approved by the party responsible for compliance shall not be made. Any such changes or modifications could void the user's authority to operate the equipment.

If necessary, the user should consult the dealer or an experienced radio/television technician for corrective action. The user may find the following booklet prepared by the Federal Communications Commission helpful: "How to Identify and Resolve Radio-TV Interference Problems." This booklet is available from the U.S. Government Printing Office, Washington, DC 20402, Stock No.004-000-00345-4.

**Warning:** This is a Class A product. In a domestic environment, this product may cause radio interference in which case the user may be required to take adequate measures.

## SAFETY PRECAUTIONS

	<b>CAUTION</b> RISK OF ELECTRIC SHOCK. DO NOT OPEN!	
<b>CAUTION: TO REDUCE THE RISK OF ELECTRICAL SHOCK, DO NOT OPEN COVERS. NO USER SERVICE-ABLE PARTS INSIDE. REFER SERVICING TO QUALIFIED SERVICE PERSONNEL.</b>		

This label may appear on the bottom of the unit due to space limitations.



The lightning flash with an arrowhead symbol within an equilateral triangle is intended to alert the user to the presence of uninsulated "dangerous voltage" within the product's enclosure that may be of sufficient magnitude to constitute a risk of electric shock to persons.



The exclamation point within an equilateral triangle is intended to alert the user to presence of important operating and maintenance (servicing) instructions in the literature accompanying the appliance.

**WARNING: TO PREVENT FIRE OR SHOCK HAZARD, DO NOT EXPOSE UNITS TO RAIN OR MOISTURE.**



**Attention:** Installation should be performed by qualified service personnel only in accordance with the National Electrical Code or applicable local codes.

**24 VAC Units:** Do Not Exceed 30 VAC Input. Voltage applied to the unit's power input should not exceed 30 VAC. Normal input voltage is 24 VAC. User supplied wiring from 24 VAC supply to unit must be in compliance with electrical codes (Class 2 power levels). Do not ground 24 VAC supply at power supply terminals or at unit's power supply terminals.

## SICHERHEITSVORKEHRUNGEN

	<b>VORSICHT</b> STROMSCHLÄGGEFAHR! BITTE NICHT ÖFFNEN!	
<b>VORSICHT: UM EINEN ELEKTRISCHEN SCHLAG ZU VERMEIDEN, ABDECKUNG NICHT ENTFERNEN. WARTUNGEN ALLER ART QUALIFIZIERTEM PERSONAL ÜBERLASSEN.</b>		

Aus Platzgründen kann diese Warnung auf der Unterseite des Gerätes angebracht sein.



Das Blitzsymbol im gleichseitigen Dreieck soll den Benutzer auf nicht isolierte "Hochspannung" im Gehäuse aufmerksam machen, die eventuell stark genug ist, um einen elektrischen Schlag zu verursachen.



Das Ausrufezeichen im gleichseitigen Dreieck soll den Benutzer auf wichtige Bedienungs- und Wartungsanleitungen in der dem Gerät beigefügten Literatur aufmerksam machen.

**WARNUNG: UM FEUER ODER ELEKTRISCHE SCHLÄGE ZU VERMEIDEN, SETZEN SIE DAS GERÄT NIEMALS REGEN ODER FEUCHTIGKEIT AUS.**



**Achtung!** Die Installation sollte nur von qualifiziertem Kundendienstpersonal gemäß jeweilig zutreffender Elektrovorschriften ausgeführt werden.

### 24 VAC Geräte

**Achtung!** 30 Volt Eingangswechselspannung darf für 24 VAC Modelle nicht überschritten werden. Normal-betrieb findet bei 24 Volt Wechselspannung statt. Die Kabel- bzw. Drahtverbindung vom Netzgerät zu dem vorliegenden Gerät muß die Bestimmungen der Schutz-klasse II erfüllen. Nicht die 24-Volt-Leitung erden weder am Netzgerät noch an den Anschlußklemmen des vorliegenden Gerätes

## SECURITE

	<b>ATTENTION</b> RISQUE D'ÉLECTROCUTION. NE PAS OUVRIR	
<b>DANGER: POUR ÉVITER TOUT RISQUE D'ÉLECTROCUTION, NE PAS OUVRIR LE BOÎTIER. IL N'Y A PAS DE PIÈCES REM-PLAÇABLES À L'INTÉRIEUR. POUR TOUTE RÉVISION, S'ADRESSER À UN TECHNICIEN SPÉCIALISÉ.</b>		

En raison de limitation de place, cette étiquette peut être placée sur le dessous de l'appareil.



L'éclair fléché dans un triangle équilatéral, avertit l'utilisateur de la présence d'une "tension dangereuse" non isolée à l'intérieur de l'appareil et d'une valeur suffisante pour constituer un risque d'électrocution.



Le point d'exclamation contenu dans un triangle équilatéral, avertit l'utilisateur de la présence, dans la documentation qui accompagne l'appareil, de consignes d'utilisation et de maintenance importantes.

**ATTENTION: POUR ÉVITER LE RISQUE D'ÉLECTROCUTION OU D'INCENDIE, NE PAS EXPOSER À LA PLUIE OU À L'HUMIDITÉ UN APPAREIL.**





**Attention:** L'installation doit être effectuée uniquement par du personnel de service qualifié conformément à la réglementation du Code Electrique National ou à la réglementation locale.

### Appareils 24 VCA

Ne pas excéder 30 VCA. La tension appliquée à l'entrée d'alimentation de l'appareil ne devrait pas excéder 30 VCA. Toute installation électrique fournissant du 24 Volts courant alternatif doit être conforme aux codes électriques. (Niveaux d'alimentation de la Classe 2). Ne pas brancher une prise de terre sur les bornes d'alimentation 24 Volts ou aux bornes d'alimentation de l'appareil.

## PRECAUCIONES DE SEGURIDAD

	<b>PRECAUCION</b> RIESGO DE CHOQUE ELÉCTRICO. NO ABRIR!	
<b>PRECAUCION: PARA REDUCIR EL RIESGO DE CHOQUE ELÉCTRICO, FAVOR NO ABRIR LA CUBIERTA. ESTE EQUIPO NO CONSTA DE PIEZAS O PARTES QUE REQUIEREN SERVICIO O MANTENIMIENTO. PARA REPARACIONES FAVOR REFERIRSE A UN TÉCNICO CALIFICADO.</b>		

Debido a limitaciones de espacio, esta etiqueta puede aparecer en la parte inferior de la unidad.



El símbolo representado por un relámpago con punta de flecha dentro de un triángulo equilátero, se muestra con el objetivo de alertar al usuario que existen "voltajes peligrosos" sin aislamiento, dentro de la cubierta de la unidad. Dichos voltajes pueden ser de tal magnitud que constituyen un riesgo de choque eléctrico a personas.



El símbolo de exclamación dentro de un triángulo equilátero, se muestra con el objetivo de alertar al usuario de que instrucciones de operación y mantenimiento importantes acompañan al equipo.

**PELIGRO: PARA EVITAR EL PELIGRO DE INCENDIO Ó CHOQUE ELÉCTRICO, NO EXPONGA A LA LLUVIA Ó HUMEDAD.**



**Atención:** La instalación de este equipo debe ser realizada por personal capacitado, solo en acuerdo, y en cumplimiento de normas del "National Electric Code" (Código Eléctrico Nacional) ó las normas del Gobierno Nacional Local.

### Unidades de 24 VCA

No exceder 30 VCA de entrada. Voltage suplido a la unidad no debe exceder 30 VCA. Voltage de entrada normal es de 24 VCA. El cableado de 24 VCA provisto por el usuario debe cumplir con las normas eléctricas (Clase 2 de niveles de alimentación). No conectar los 24 VCA a tierra en las terminales de la alimentación ó a las terminales de la fuente de alimentación de la unidad.



**Do Not Exceed 30 VAC Input** on 24 VAC models. Operation above 30 VAC violates low voltage operation (Class 2 Specifications). Normal operation is 24 VAC.

TUV Approved 24 VAC Models



**Caution:** Use an approved power supply incorporating reinforced insulation from primary to secondary to isolate unit from Mains.

## 1. Unpacking

Unpack Carefully. This is electromechanical equipment and should be handled with care. Check to ensure that the following items are included:

- Camera and Housing with Sunshield
- Hardware Kit
  - i. (4) #8 x 1" Sheet Metal Screws
  - ii. (4) Wall Anchors
  - iii. (1) 1/16" Allen Wrench
  - iv. (1) 1/8" Allen Wrench

## 2. Service

If the unit ever needs repair service or parts, the customer should contact Aigis Mechtronics for authorization to return and shipping instructions.

## 3. General Care / Maintenance

Regularly scheduled maintenance will help prolong the operational life of this unit. Clean the viewing window as needed with a mild, nonabrasive detergent in water and a soft cloth.

## 4. Description and Specifications

- The Mini-Line Track Light series CCTV camera enclosures operate on 24VAC  $\pm 10\%$  at 15W max. It contains a camera with a 1/3" CCD imager, a varifocal lens, and a ring of 36 IR LEDs for nighttime viewing. The enclosures are rated IP66 and feature external focus and zoom adjustment knobs.
- Housing Construction / Finish: Machined aluminum with glass viewing window, powder coat paint.

## 5. Installation

Attention: Installations should be performed by qualified service personnel only in accordance with the National Electrical Code or applicable local codes.

## 6. Assembly Instructions

- 6.1. The housing ships from the factory fully assembled. Do not attempt to open the enclosure due to the risk of electric shock. The housing contains no user-serviceable parts. Call an Aigis Mechtronics sales representative if the unit is not operating properly.

## 7. Mounting Instructions

- 7.1. Included with the hardware kit are compatible mounting screws and wall anchors. If using different mounting hardware, the mounting holes accept fasteners up to 0.171" (4.34mm) in diameter. To mount properly, the head of the screw cannot exceed 0.285" (7.24mm) in diameter.
- 7.2. By loosening the set screw, the base of the bracket can be unscrewed and used as a template for marking the hole pattern need to mount the unit. Drill a center hole large enough to accept the BNC connector and power connectors.
- 7.3. The base contains a slot for the power and video wires to exit the housing if the wires are not being fed into the wall/ceiling. If possible, leave the video wire available for testing the zoom and focus setting with a test monitor (see section 6).
- 7.4. The 3-axis mounting bracket is fully adjustable to attain any viewing angle. See Figure 1 for bracket adjustment instructions.

## 8. Camera / Lens Adjustment

- 8.1. This camera features external zoom and focus knobs. Once the desired viewing angle is attained, connect a test monitor to the BNC connector and power the unit using 24VAC. If the knob is too tight to turn, unscrew the screw in the center of the knob (1/4 turn at a time) until the knob can be turned. Be careful not to unscrew the knob entirely.
- 8.2. Once the zoom and focus settings are in the desired range, tighten the screws to lock the knobs in place.

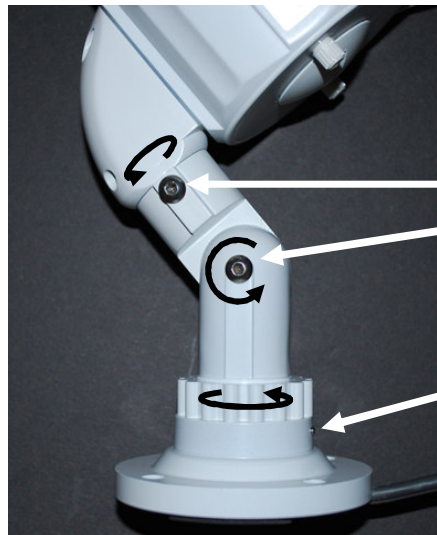

Loosen to adjust viewing angle using the 1/8" Allen wrench.

Set Screw (use 1/16" Allen wrench to adjust)

Figure 1 – Mounting Bracket Adjustment

