

LCN®

Concealed closers





Strength and performance for aesthetically driven applications

Allegion's LCN door control portfolio is at the top of its class because of its high-quality construction and reliable performance. LCN's rich history started in 1877 when its founder was hired to solve the problem of slamming church doors in Boston, leading to the world's first door check.

Built from the inside out, the LCN portfolio combines tougher, bolder construction with proven technology – setting the standards for reliability, longevity and value in high-use applications. Reliability means control over door speed, latch engagement and, ultimately, how well a door with an LCN closer operates in the field.

The overhead concealed closer series features heavy duty construction and smooth, quiet operation. Featuring a high strength cast iron cylinder, you won't compromise strength and performance to meet your desired aesthetic.

LCN was formed on the belief that quality sets us apart. With millions of door closers installed in facilities across the world and backed by support at every point of interaction no matter your role in the industry, you can be confident in choosing LCN.

Features that set concealed closers apart

- Concealment in either the head frame or top rail of the door for aesthetically driven applications
- Features quiet, low friction track and roller combination for all standard arm closers
- Includes high strength cast iron cylinder, and full rack and pinion hydraulic action
- Adjustable hydraulic backcheck cushions and separate regulation of general closing speed and latching speed



Information and customer care



us.allegion.com



US 877.671.7011
Canada 800.900.4734



support@allegion.com
Closers_TechProdSupport@allegion.com



www.youtube.com/LCNHardware

Ordering



Allegion_Orders@allegion.com



eFax: 1.800.248.1460

Concealed mounted closers

Product selection guide

The concealed LCN closers feature a modern design for concealment in either the head frame or top rail of the door. This guide is based on the desired mounting of the closer.

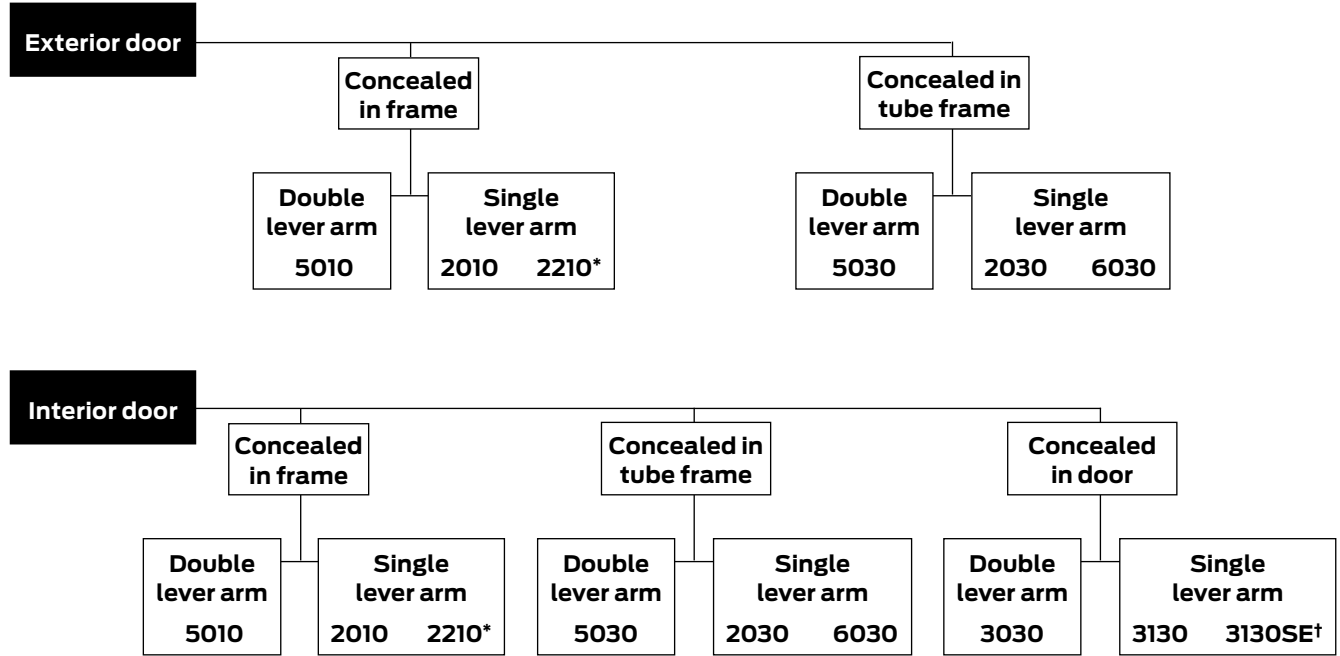

* Indicates high security closer, door position switch optional. Refer to high security catalog.
 † Indicates fire life safety closer. Refer to fire life safety catalog.

Product comparison

This chart shows a basic comparison of concealed closers. Refer to the specific closer chapter for complete details.

	Mounting			Finish		Cylinder		Arm		Arm function*				
	In frame	In 1 3/4" tube	In door	Powder coat	Plated	Handed	Sized	Accessibility	Delay action	Concealed	Exposed	Standard (single)	Regular (double)	Hold open
2010	■	■	■	■	■	■	■	■	■	■	■	180°	110°	
2030	■	■	■	■	■	■	■	■	■	■	■	180°	110°	
3030	■	■	■	■	■	■	■	■	■	■	■	180°	140°	
3130	■	■	■	■	■	■	■	■	■	■	■	140°	100°	
5010	■	■	■	■	■	■	■	■	■	■	■	180°	100°	
5030	■	■	■	■	■	■	■	■	■	■	■	180°	100°	
6030	■	■	■	■	■	■	■	■	■	■	■	95°	95°	

■ Available ■ Not available ♿ Closer available with less than 5.0 lbs. opening force on 36" door.
 * Maximum opening/Hold open point with standard template. See individual closer series for degrees of opening per installation.

Applications

- For aluminum, hollow metal, or wood doors and frames
- Can be used with hinge or pivot mounted door
- Closers for 4" or minimum 1 3/4" head frame or 4" top rail
- Mounting clips for wood frames and other installation accessories available for non-standard conditions
- For concealed in door closers consult factory for installations with pivots

Features common to concealed closers

- Mountings for head frame or door top rail
- Handed for right or left swinging doors (except 6030)
- Closers to meet ADA reduced opening force requirements
- Adjustable hydraulic back check cushions opening swing prior to 90°
- Separate regulation of general closing speed and latching speed
- Joints in arm and shoe adapt to uneven trim (for double lever arms)

Design assistance

LCN has been providing reliable solutions to unique door control problems since 1925. Design and specification assistance are only a phone call away. Contact LCN for assistance or technical information at 877-671-7011, fax 800-248-1460 for Order Entry, or fax 815-879-1495 for Product Support.

Warranty

15 year limited warranty. See General Information catalog for complete warranty details.

Specifications

Refer to "Specifications" section for suggested architectural specifications.

Materials

(Closers concealed in the door or frame)

- High strength cast iron cylinder
- Forged steel main arms (except 6030)
- One piece forged steel piston
- All weather fluid in overhead concealed models performs to temperature ranges from 120°F (49°C) to -30°F (-35°C) without any seasonal adjustment
- High efficiency, full complement, low friction bearings
- Full rack and pinion hydraulic action
- Quiet, low friction track and roller combination for all single lever (standard) arm closers

Finishes

- Available in seven standard or a wide selection of optional custom powder coat finishes to blend with door and frame
- LCN's powder coat finishes surpass 100 hours of salt spray which is over four times the ANSI standard for corrosion resistance
- For installations where a higher level of corrosive resistance is required, LCN offers an optional Special Rust Inhibitor (SRI) pretreatment
- Closers that combine the exclusive LCN powder coat finish and the SRI pre-treatment exceed the ANSI standard for corrosion resistance even further
- Plated finishes are available as an option to accent door and frame (SRI not available with plated finishes)

Listings and approvals

UL listed for self-closing doors without hold open to UL10C. Tested and certified under ANSI/BHMA Standard A156.4. Consult factory for other listings such as: cUL, California State Fire Marshal, Bureau of Standards and Appeals.

Positive pressure 

LCN closers have been certified for three hours by UL to be in compliance with UL 10C. Contact LCN for specific details on door closer fire ratings.

Fasteners

- Standard Wood and machine screws (WMS) contains Phillips head wood and machine screws to install the closer
- Torx machine screws are available for some closers

Note: Phillips head metric machine screws are available, please specify.

Maintenance

Closers mounted according to LCN installation instructions require no periodic maintenance or adjustments.

2010 Series

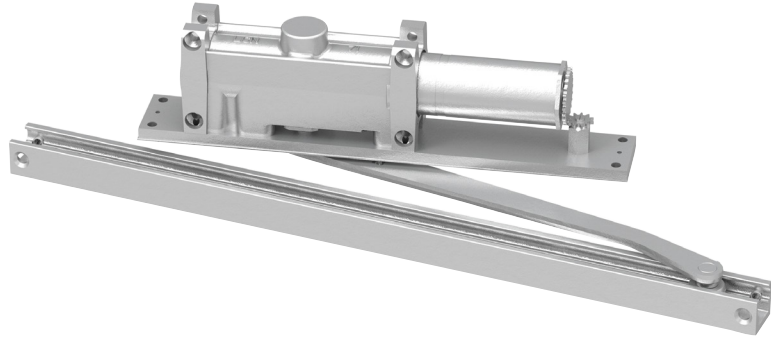

The concealed 2010 Series is a heavy duty closer designed to provide complete concealment. The single lever arm and roller assembly provide smooth, quiet door control and the choice of finishes and track functions meet virtually all architectural requirements.

Features

Certifications	Grade 1 - ANSI/BHMA A156.4, UL 10 C, ADA, 100 hour salt spray, meets BAA - Buy American Act	Fasteners	Wood and machine screws (WMS)
Body construction	<ul style="list-style-type: none"> Cast iron body Full complement bearing 1 1/2" diameter piston 1/8" diameter double heat treated pinion journal 	Mounting	Concealed (in frame); aluminum frame requires minimum 4" x 4" (102 mm) tube
Fluid	All weather fluid	Arms	Standard arm and track
Handing	Handed	Finishes/colors/ powder coat	<ul style="list-style-type: none"> 622 Matte black 689 Aluminum 690 Statuary bronze 691 Light bronze 693 Gloss black 695 Dark bronze 696 Brass Custom colors optional Optional SRI primer - powder coat only Optional plated finishes
Size	Sized 1-6		
Warranty	15 years		

Product configurations

Mounting	Finish	Cylinder	Arm	Arm function*
In frame In 1 3/4" tube In door	Powder coat Plated Handed Sized	Accessibility Delay action	Concealed Exposed	Standard (single) Regular (double) Hold open
■ Available ■ Not available	■ Available ■ Not available	■ Available ■ Not available	■ Available ■ Not available	180° 110°

■ Closer available with less than 5.0 lbs. opening force on 36" door.
 * Maximum opening/Hold open point with standard template. See individual closer series for degrees of opening per installation.

Customized installation templates or products may be available to solve non-standard applications. Contact LCN Product Support for assistance.

Mounting details

Concealed mounting

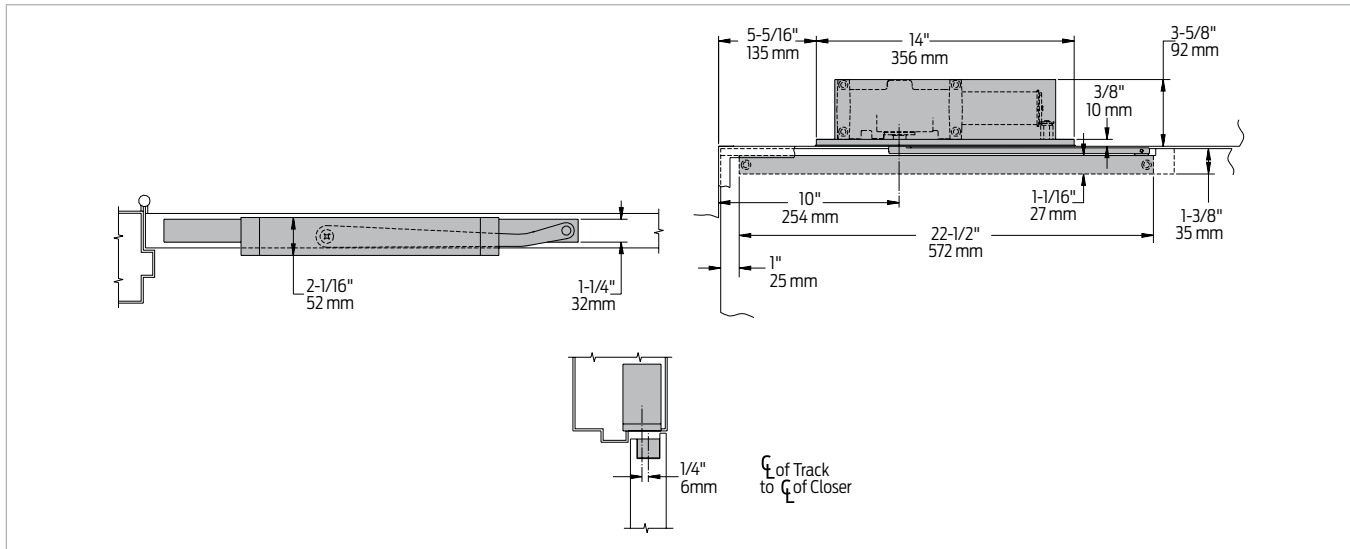

Butt hinges	Should not exceed 5" (127 mm) in width
Auxiliary stop	<ul style="list-style-type: none"> Recommended where a door cannot swing 180° Optional track bumper assembly assists back check in cushioning the opening swing of the door (not intended to replace an auxiliary stop)
Top rail	<ul style="list-style-type: none"> 1 3/8" (35 mm) mortise required With Fire shield, 1 13/32" (36 mm) mortise required 5/16" (8 mm) cutout required at top of the door, stop face only
Door thickness	1 3/4" (44 mm) minimum
Hollow metal frame	Consult factory for installation instructions
Maximum opening	<ul style="list-style-type: none"> Butt hinge template allows 180°, trim permitting Limited to 110° when optional bumper is installed Adjustable Hold open points from 85° to 110°, with Hold open track (H) Offset pivot template allows 110°, trim permitting Limited to 95° when optional bumper is installed Adjustable Hold open points from 75° to 95°, with Hold open track (H) Center pivot template allows 120°, trim permitting Limited to 95° when optional bumper is installed Adjustable Hold open points from 75° to 95°, with Hold open track (H)

Notes:

- For interior or exterior doors
- Single acting cylinder in head frame
- Concealed arm and track in door top rail

Accessories

Cylinders



**2011(3)(4)(5)(6)-3071
Cast iron cylinder assembly
with mounting plate (CYL)**

- Handed
- With mounting plate
- Standard

Arms



**2010-3077T
Standard arm (STDTRKARM)**

- Handed
- Track roller not included with arm

Tracks



**2010-3038
Standard track (STDTRK)**

- Non-handed
- Non hold open
- Will accept hold open clip and/or bumper assembly
- Standard



**2010-3038B
Track with bumper (BUMP)**

- Non-handed
- Non hold open
- Will accept hold open clip
- Optional



**2010-3038H
Hold open track (H)**

- Non-handed
- Will accept bumper assembly
- Optional



**2010-3038HB
Hold open track with bumper (HBMP)**

- Non-handed
- Optional

Installation accessories



**2010-420
Fire shield**

- 22 gauge steel liner mounts in the track mortise of the door's top rail for 20 minute labeled wood doors



**2010-169
Track bumper**

- Mounts in track to assist back check
- Limits maximum opening
- Consists of bumper, bumper post and mounting screw

Note: Track bumper does not replace auxiliary stop.



**2010-3054
Hold open clip**

- Mounts in track to provide hold open function
- Hold open point controlled by clip location
- Requires 2010-3034H



**2010-3034
Track roller**

- Quiet, low friction roller assembly
- Shoulder dimension "X" = 1/16" (2 mm)



**2010-3034H
Hold open track roller**

- Quiet, low friction roller assembly
- Shoulder dimension "X" = 1/16" (2 mm)

Ordering information

How-to-order 2010 Series closers

1. Select cylinder size

- 2011
- 2013
- 2014
- 2015
- 2016

2. Specify hand

- Right hand (RH)
- Left hand (LH)

3. Select finish

- Standard powder coat _____
Matte black (622), Aluminum (689), Dark bronze (695), Statuary bronze (690), Light bronze (691), Gloss black (693), or Brass (696)

Closer will be shipped with:

- Standard cylinder with finish plate
- Standard arm
- Standard track
- Wood and machine screws
(unless options listed below are selected)

Closer options

Track

- Track with bumper (BUMP)
- Hold open track (H)
- Hold open Track with bumper (HBMP)

Finish

- Custom powder coat (RAL) _____
- Plated finish _____
- SRI primer (use with powder coat finishes only)

Screw pack

- Torx machine screws (TORX)

Installation accessories

- Fire shield, 2010-420

Special template

- ST- _____

Table of sizes

- Select closer based on width of door
- 2010 Series cylinders available in size 1, 3, 4, 5 or 6
- Closing power of all 2010 Series closers may be increased 15%
- Specify next higher size closer where strong drafts exist

Exterior (and vestibule) door width

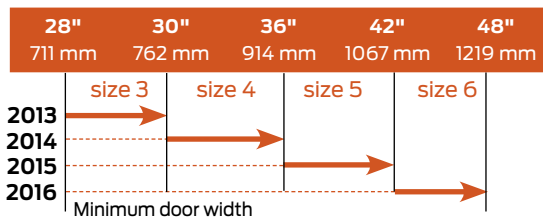

Interior door width

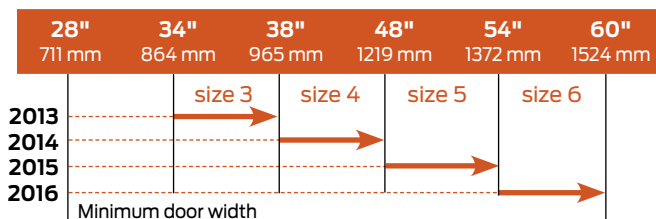

→ Indicates recommended range of door width for closer size.

Reduced opening force 2010 Series closers

CAUTION! Any manual door closer, including those certified by BHMA to conform to ANSI Standard A156.4, that is selected, installed and adjusted based on ADA or other reduced opening force requirements may not provide sufficient power to reliably close and latch a door.

Refer to Automatic Operators catalog for information on systems that meet reduced opening force requirements without effecting closing power.

	Door width	36"	42"	48"
	8.5* lbs.	2014	2014	2015
	5.0* lbs.	2011	2011	2013

* Maximum opening force.

2030 Series

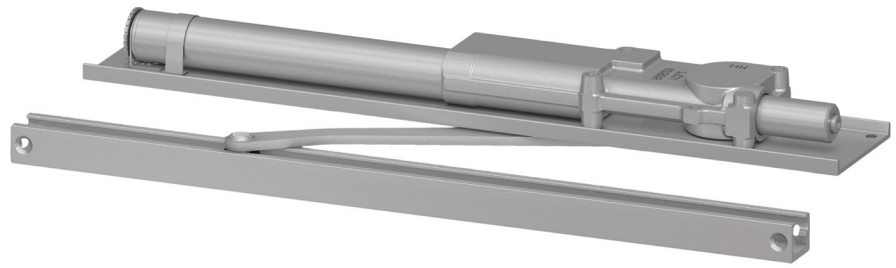

The concealed 2030 Series PACER[®] is a heavy duty closer designed to fit in a narrow, minimum 1 3/4" aluminum transom. The single lever arm and roller assembly provide smooth, quiet door control and the choice of finishes and track functions meet virtually all architectural requirements.

Features

Certifications	ANSI/BHMA A156.4, UL 10C, ADA, 100 hour salt spray, meets BAA - Buy American Act	Fasteners	Wood and Machine Screws (WMS)
Body construction	<ul style="list-style-type: none"> Cast iron body Full complement bearing 1 1/8" diameter piston 1/16" diameter double heat treated pinion journal 	Mounting	Concealed (in tube); aluminum frame requires minimum 1-3/4" (44 mm) x 4" (102 mm) tube
Fluid	All weather fluid	Arms	Standard arm and track
Handing	Handed	Finishes/colors/powder coat	<ul style="list-style-type: none"> 622 Matte black 689 Aluminum 690 Statuary bronze 691 Light bronze 693 Gloss black 695 Dark bronze 696 Brass Custom colors optional Optional SRI primer - powder coat only Optional plated finishes
Size	Sized 1-5		
Warranty	15 years		

Product configurations

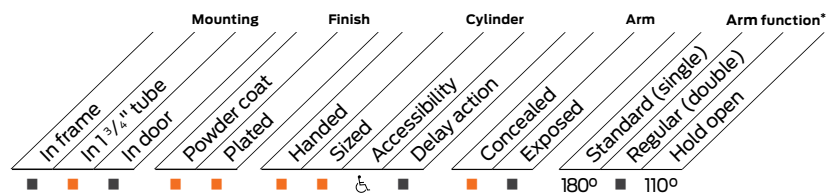

- Available
- Not available

♿ Closer available with less than 5.0 lbs. opening force on 36" door.

* Maximum opening/Hold open point with standard template. See individual closer series for degrees of opening per installation.

Customized installation templates or products may be available to solve non-standard applications. Contact LCN Product Support for assistance.

Mounting details

Concealed mounting

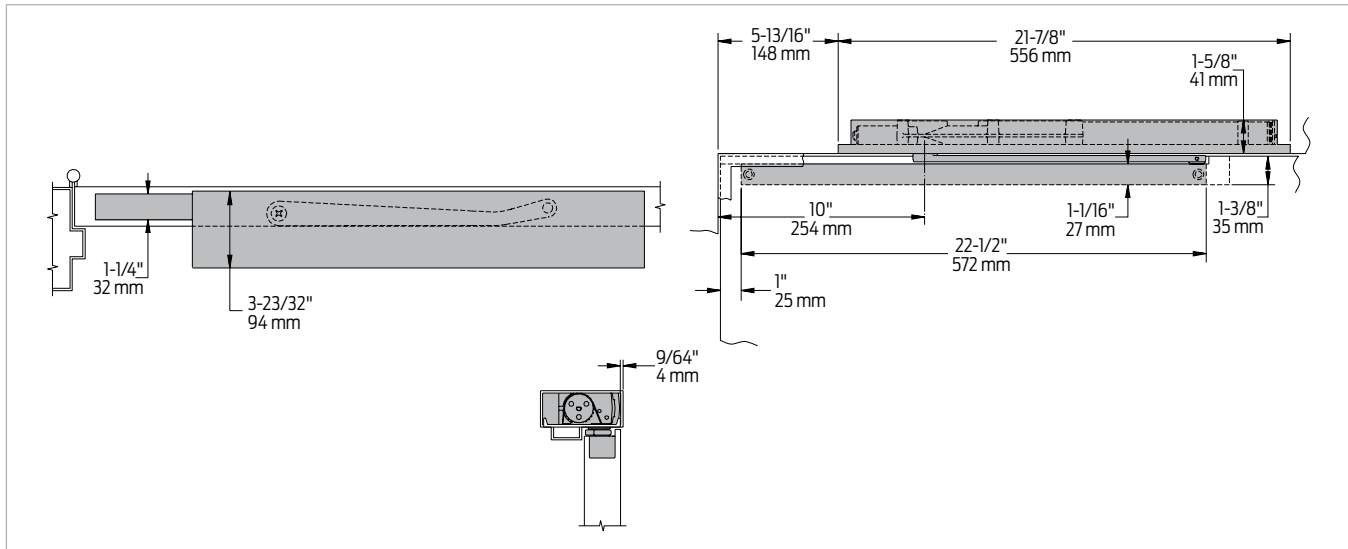

Butt hinges	Should not exceed 5" (127 mm) in width
Auxiliary stop	<ul style="list-style-type: none"> Recommended where a door cannot swing 180° Optional track bumper assembly assists back check in cushioning the opening swing of the door (not intended to replace an auxiliary stop)
Top rail	<ul style="list-style-type: none"> 1 3/8" (35 mm) mortise required With fire shield, 1 13/32" (36 mm) mortise required 5/16" (8 mm) cutout required at top of the door, stop face only
Door thickness	1 3/4" (44 mm) minimum
Hollow metal frame	Consult factory for installation instructions
Wood frame	Installation simplified by Wood mounting clip set 2030-416 for center pivoted or 2030-417 for offset pivoted and butt hung installations. Consult factory for preparation details.
Maximum opening	<ul style="list-style-type: none"> Butt hinge template allows 180°, trim permitting Limited to 110° when optional bumper is installed Adjustable Hold open points from 85° to 110°, with Hold open track (H) Consult factory if door will be held open at 180° Offset pivot template allows 115°, trim permitting. Limited to 95° when optional bumper is installed Hold open point from 85°, with Hold open track (H) Center pivot template allows 120°, trim permitting Limited to 100° when optional bumper is installed Adjustable Hold open points from 85° to 100°, with Hold open track (H)

Notes:

- For interior or exterior doors
- Single acting cylinder in head frame
- Concealed arm and track in door top rail

Accessories

Cylinders



**2031(2)(3)(4)(5)-3071
Cast iron cylinder assembly
with mounting plate (CYL)**

- Handed
- With mounting plate
- Standard

Arms



**2030-3077T
Standard arm (STDTRKARM)**

- Handed
- Track roller not included with arm

Tracks



**2030-3038
Standard track (STDTRK)**

- Non-handed
- Non hold open
- Will accept hold open clip and/or bumper assembly
- Standard



**2030-3038B
Track with bumper (BUMP)**

- Non-handed
- Non hold open
- Will accept hold open clip
- Optional



**2030-3038H
Hold open track (H)**

- Non-handed
- Will accept bumper assembly
- Optional



**2030-3038HB
Hold open track with bumper (HBMP)**

- Non-handed
- Optional

Installation accessories



**2030-420
Fire shield**

- 22 gauge steel liner mounts in the track mortise of the door's top rail for 20 minute labeled wood doors

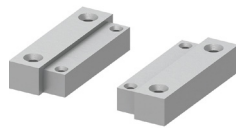

**2030-416
Wood mounting clip set**

- Simplifies mounting center pivoted 2030 closer in wood frame
- Includes latch stile clip, hinge stile clip and cover
- For use with Ives center pivots
- Consult factory for special template



**2030-417
Wood mounting clip set**

- Simplifies mounting offset pivoted or butt hung 2030 closer in wood frame
- Includes two clips
- For use with offset pivots
- Consult factory for special template



**2030-169
Track bumper**

- Mounts in track to assist back check
- Limits maximum opening
- Consists of bumper, bumper post and mounting screw

Note: Track bumper does not replace auxiliary stop.

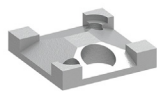

**2030-3054
Hold open clip**

- Mounts in track to provide hold open function
- Hold open point controlled by clip location
- Requires 2030-3034H hold open track roller



**2030-3034
Track roller**

- Quiet, low friction roller assembly
- Shoulder dimension "X" = 1/16" (2 mm)



**2030-3034H
Hold open track roller**

- Quiet, low friction roller assembly
- Shoulder dimension "X" = 1/16" (2 mm)

Ordering information

How-to-order 2030 Series closers

1. Select cylinder size

- 2031
- 2032
- 2033
- 2034
- 2035

2. Specify hand

- Right hand (RH)
- Left hand (LH)

3. Select finish

- Standard powder coat _____
Matte black (622), Aluminum (689), Dark bronze (695), Statuary bronze (690), Light bronze (691), Gloss black (693), or Brass (696)

Closer will be shipped with:

- Standard cylinder with mounting plate
- Standard arm
- Standard track
- Wood and machine screws
(unless options listed below are selected)

Closer options

Track

- Track with bumper (BUMP)
- Hold open track (H)
- Hold open track with bumper (HBMP)

Finish

- Custom powder coat (RAL) _____
- Plated finish _____
- SRI primer (use with powder coat finishes only)

Screw pack

- Torx machine screws (TORX)

Installation accessories

- Fire shield, 2030-420
- Wood clip set, 2030-416
- Wood clip set, 2030-417

Special template

- ST- _____

Table of sizes

- Select closer based on width of door.
- 2030 Series cylinders available in size 1, 2, 3, 4, or 5
- Closing power of all 2030 Series closers may be increased 35%
- Specify next higher size closer where strong drafts exist

Exterior (and vestibule) door width

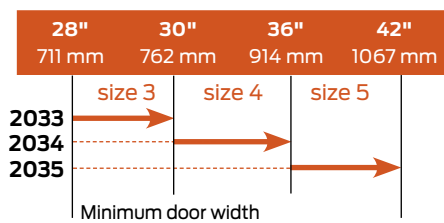

Interior door width

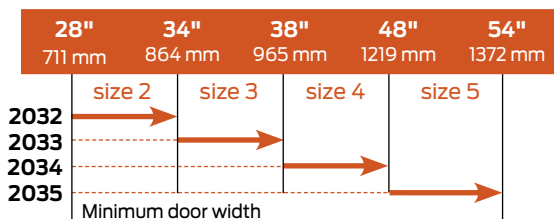

→ Indicates recommended range of door width for closer size.

Reduced opening force 2030 Series closers

CAUTION! Any manual door closer, including those certified by BHMA to conform to ANSI Standard A156.4, that is selected, installed and adjusted based on ADA or other reduced opening force requirements may not provide sufficient power to reliably close and latch a door.

Refer to Automatic Operators catalog for information on systems that meet reduced opening force requirements without effecting closing power.

Door width	36"	42"	48"
 8.5* lbs.	2033	2033	2034
5.0* lbs.	2031	2032	2032

* Maximum opening force.

3030 Series

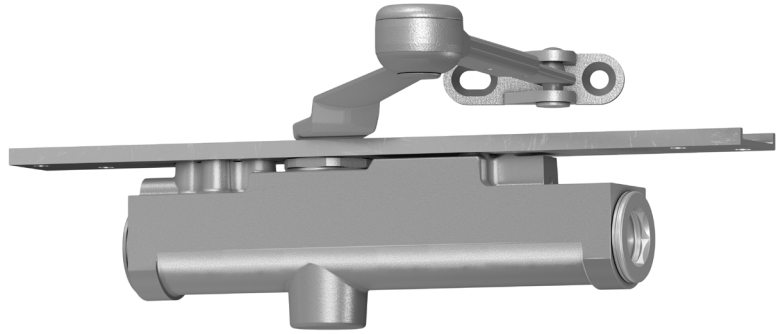

The concealed 3030 Series is designed to mount in a 1 3/4" interior door. The double lever arm provides superior door control and the choice of finishes and arm functions meet virtually all architectural requirements.

Features

Certifications	Grade 1 - ANSI/BHMA A156.4, UL 10C, ADA, 100 hour salt spray, meets BAA - Buy American Act	Mounting	Concealed (in door); consult factory for installations with pivots
Body construction	<ul style="list-style-type: none"> Cast iron body Full complement bearing 1 1/8" diameter piston 	Arms	Regular arm
Fluid	All weather fluid	Finishes/colors/powder coat	<ul style="list-style-type: none"> 622 Matte black 689 Aluminum 690 Statuary bronze 691 Light bronze 693 Gloss black 695 Dark bronze 696 Brass Custom colors optional
Handing	Handed		<ul style="list-style-type: none"> Optional SRI primer - powder coat only Optional plated finishes
Size	Sized 1-4		
Warranty	15 years		
Fasteners	Wood screws and torx security screws (optional)		

Product configurations

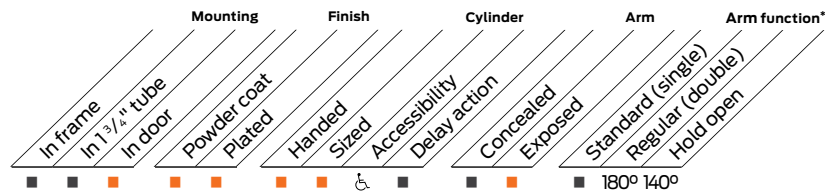

■ Available
 ■ Not available

♿ Closer available with less than 5.0 lbs. opening force on 36" door.
 * Maximum opening/Hold open point with standard template. See individual closer series for degrees of opening per installation.

Customized installation templates or products may be available to solve non-standard applications. Contact LCN Product Support for assistance.

Mounting details

Concealed mounting

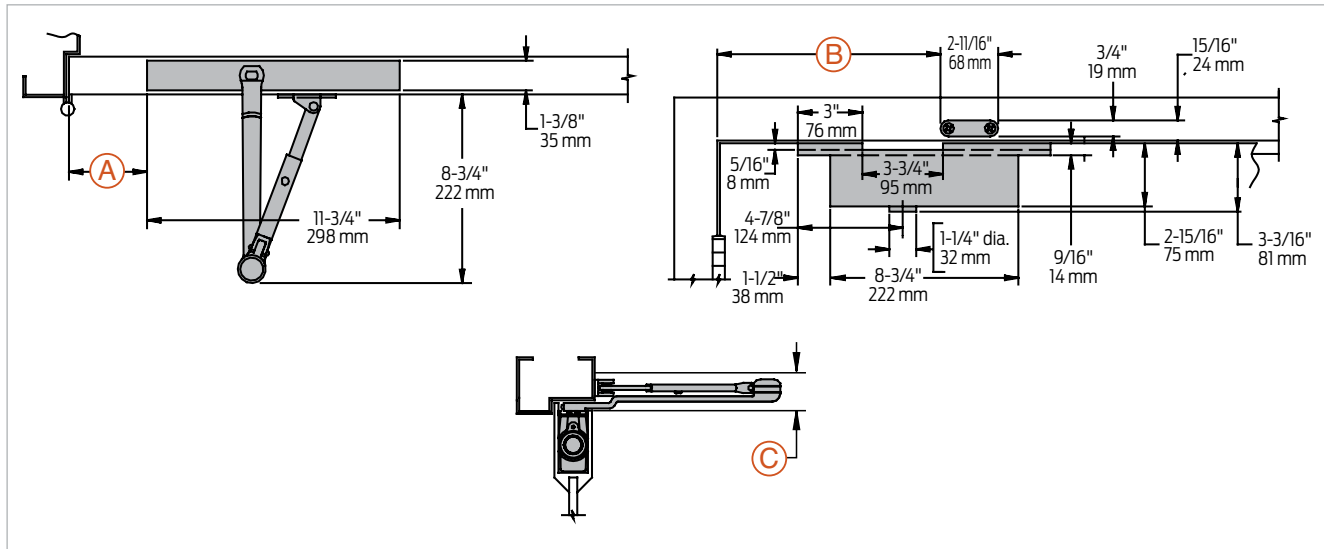

Butt hinges	Should not exceed 5" (127 mm) in width
Auxiliary stop	Recommended at Hold open point or where a door cannot swing 180°
Reveal	Minimum 4" (102 mm) required
Top rail	<ul style="list-style-type: none"> 1 3/4" (44 mm) minimum Please consult the door manufacturer to assure that the door integrity and warranty is maintained after installing the 3030 Series door closer in a 1 3/4" thick wood door
Clearance	2 13/16" (72 mm) behind door required for 90° installation
Delay action	Delays closing from 180°-70° Delay time adjustable up to approximately 1 minute
Maximum opening	<p>To 100°: A = 3 5/8" (92 mm) B = 10 1/4" (260 mm)</p> <p>130°: A = 2 5/8" (67 mm) B = 9 1/4" (235 mm)</p> <p>180°: A = 1 5/8" (41 mm) B = 8 1/4" (210 mm)</p> <p>Hold open points up to maximum opening or 140°, whichever is less, with Hold open Arm (H)</p> <p>Arm clearance above door: C = 1 1/4" (32 mm)</p>

Notes:

- For interior doors
- Single acting cylinder in top rail of door
- Exposed arm on hinge side of door

3030 Series

Accessories

Cylinders



3031(2)(3)(4)-3071
Cast iron cylinder assembly with mounting plate (CYL)

- Handed
- With mounting plate
- Standard



3030-3077
Regular arm (REGARM)

- Non-handed



3030-3049
Hold open arm (H)

- Handed
- Provides hold open function, adjustable at elbow
- Optional

Ordering information

How-to-order 3030 Series closers

- 1. Select cylinder size**
 - 3031
 - 3032
 - 3033
 - 3034
- 2. Specify hand**
 - Right hand (RH)
 - Left hand (LH)
- 3. Select finish**
 - Standard powder coat _____

Matte black (622) Aluminum (689), Dark bronze (695), Statuary bronze (690), Light bronze (691), Gloss black (693), or Brass (696)

Closer will be shipped with:

- Standard cylinder
- Regular arm
- Wood and machine screws
(unless options listed below are selected)

Closer options

Arm

- Hold open arm (H)

Finish

- Custom powder coat (RAL) _____
- Plated finish _____
- SRI primer (use with powder coat finishes only)

Screw pack

- Torx machine screws (TORX)

Special template

- ST- _____

Table of sizes

- Select closer based on width of door
- 3030 Series cylinders available in size 1, 2, 3, or 4
- Closing power of all 3030 Series closers may be increased 15%

Reduced opening force 3030 Series closers

CAUTION! Any manual door closer, including those certified by BHMA to conform to ANSI Standard A156.4, that is selected, installed and adjusted based on ADA or other reduced opening force requirements may not provide sufficient power to reliably close and latch a door.

Refer to Automatic Operators catalog for information on systems that meet reduced opening force requirements without effecting closing power.

Door width	36"	42"	48"
 8.5* lbs.	N/A	N/A	N/A
5.0* lbs.	3031	3031	3032

* Maximum opening force.

Interior door width

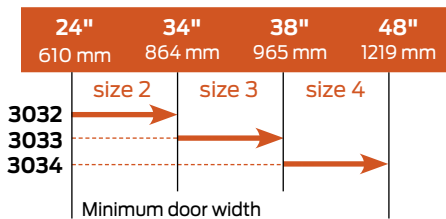

→ Indicates recommended range of door width for closer size.

3130 Series

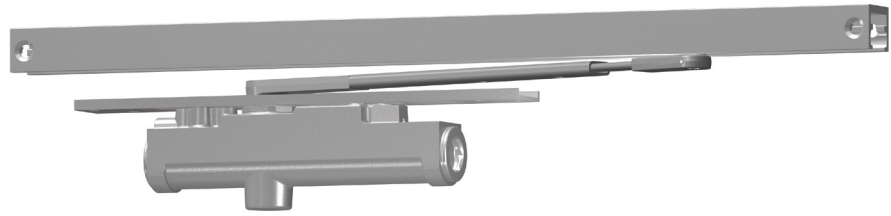

The concealed 3130 Series is designed to mount in a 1 3/4" interior door. The single lever arm and roller assembly provides complete concealment and the choice of finishes and track functions meet virtually all architectural requirements.

Features

Certifications	Grade 1 - ANSI/BHMA A156.4, UL 10C, ADA, 100 hour salt spray, meets BAA - Buy American Act	Mounting	Concealed (in door); consult factory for installation with pivots
Body construction	<ul style="list-style-type: none"> Cast iron body Full complement bearing 1 1/8" diameter piston 	Arms	Standard arm and track
Fluid	All weather fluid	Finishes/colors/powder coat	<ul style="list-style-type: none"> 622 Matte black 689 Aluminum 690 Statuary bronze 691 Light bronze 693 Gloss black 695 Dark bronze 696 Brass Custom colors optional
Handing	Handed		<ul style="list-style-type: none"> Optional SRI primer - powder coat only Optional plated finishes
Size	Sized 1-3		
Warranty	15 years		
Fasteners	Wood screws and torx security screws (optional)		

Product configurations

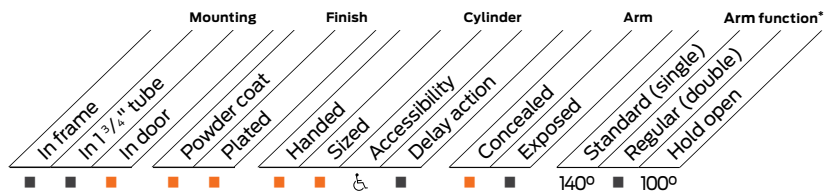

■ Available
 ■ Not available

♿ Closer available with less than 5.0 lbs. opening force on 36" door.

* Maximum opening/Hold open point with standard template. See individual closer series for degrees of opening per installation.

Customized installation templates or products may be available to solve non-standard applications. Contact LCN Product Support for assistance.

Mounting details

Concealed mounting

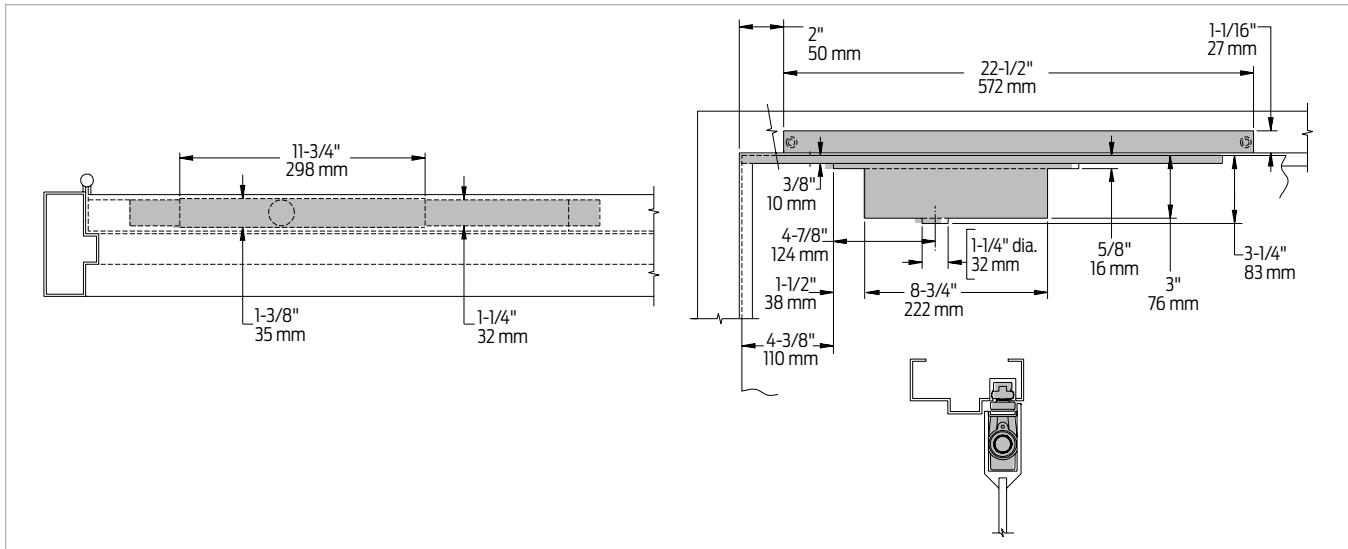

Butt hinges	Should not exceed 5" (127 mm) in width
Auxiliary stop	<ul style="list-style-type: none"> Recommended at Hold open point or where a door cannot swing 140° Optional track bumper assembly assists back check in cushioning the opening swing of the door (it is not intended to replace an auxiliary stop)
Top rail	Minimum 4" (102 mm) required
Door thickness	<ul style="list-style-type: none"> 1 3/4" (44 mm) minimum. Please consult the door manufacturer to assure that the door integrity and warranty is maintained after installing the 3130 Series door closer in a 1 3/4" thick wood door
Door width	2' 2" (660 mm) minimum
Maximum opening	<ul style="list-style-type: none"> Templating allows 140°, trim permitting, 100° with optional bumper installed Adjustable Hold open points from 85° to 100°, with Hold open track (H)

Notes:

- For interior doors
- Single acting cylinder and standard arm in top rail of door
- Concealed track in head frame
- Consult factory for installations with pivots

Accessories

Cylinders



- 3131(2)(3)-3071**
Cast iron cylinder assembly with mounting plate (CYL)
- Handed
 - With mounting plate
 - Standard

Arms



- 3130-3077T**
Standard arm (STDTRKARM)
- Handed
 - Track roller not included with arm
 - Standard

Tracks



- 3130-3038H**
Hold open track (H)
- Non-handed
 - Will accept bumper assembly
 - Optional



- 3130-3038B**
Track with aumper (BUMP)
- Non-handed
 - Non hold open
 - Will accept hold open clip
 - Optional



- 3130-3038H**
Hold open track (H)
- Non-handed
 - Will accept bumper assembly
 - Optional



- 3130-3038HB**
Hold open track with bumper (HBMP)
- Non-handed
 - Optional

Installation accessories

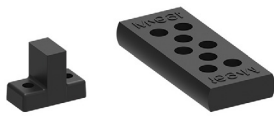

- 3130-169**
Track bumper
- Mounts in track to assist back check, does not replace auxiliary stop
 - Limits maximum opening
 - Consists of bumper, bumper post and mounting screw

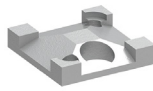

- 3130-3054**
Hold open clip
- Mounts in track to provide hold open function
 - Hold open point controlled by clip location
 - Requires 3130-3034H Hold open track roller



- 3130-3034**
Track roller
- Quiet, low friction roller assembly
 - Shoulder dimension "X" = 1/8" (3 mm)



- 3130-3034H**
Hold open track roller
- Quiet, low friction roller assembly
 - Shoulder dimension "X" = 1/8" (3 mm)

Ordering information

How-to-order 3130 Series closers

1. Select cylinder size

- 3131
- 3132
- 3133

2. Specify hand

- Right hand (RH)
- Left hand (LH)

3. Select finish

- Standard powder coat _____
Matte black (622), Aluminum (689), Dark bronze (695), Statuary bronze (690), Light bronze (691), Gloss black (693), or Brass (696)

Closer will be shipped with:

- Standard cylinder
- Standard cover
- Standard arm
- Track roller
- Standard track
- Self-reaming and tapping screws (unless options listed below are selected)

Closer options

Track

- Track with bumper (BUMP)
- Hold open track (H)
- Hold open Track with bumper (HBMP)

Finish

- Custom powder coat (RAL) _____
- Plated finish _____
- SRI primer (use with powder coat finishes only)

Screw pack

- Torx machine screws (TORX)

Special template

- ST- _____

Table of sizes

- Select closer based on width of door
- 3130 Series cylinders available in size 1, 2, or 3
- Closing power of 3130 Series closers is not adjustable

Interior door width

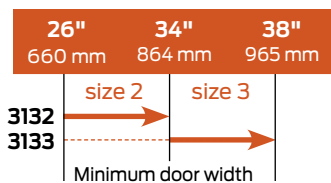

→ Indicates recommended range of door width for closer size.

Reduced opening force 3130 Series closers

CAUTION! Any manual door closer, including those certified by BHMA to conform to ANSI Standard A156.4, that is selected, installed and adjusted based on ADA or other reduced opening force requirements may not provide sufficient power to reliably close and latch a door.

Refer to Automatic Operators catalog for information on systems that meet reduced opening force requirements without effecting closing power.

Door width	36"	42"	48"
8.5* lbs.	N/A	N/A	N/A
5.0* lbs.	3131	3131	3132

* Maximum opening force.

5010 Series

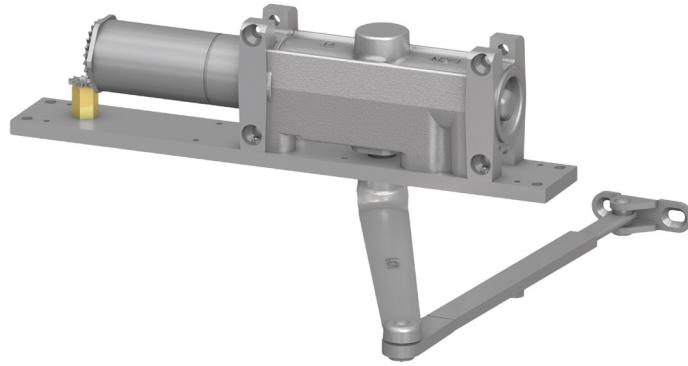

The concealed 5010 Series is a heavy duty closer designed for institutional, high traffic, or other applications exposed to weather or abuse. The double lever arm provides superior door control and a choice of finishes, cylinder functions, and arm functions that meet virtually all architectural requirements.

Features

Certifications	Grade 1 - ANSI/BHMA A156.4, UL 10C, ADA, 100 hour salt spray, meets BAA - Buy American Act	Mounting	Concealed (in frame); aluminum frame requires 4" (102 mm) x 4" tube
Body construction	<ul style="list-style-type: none"> Cast iron body Full complement bearing 1 1/2" diameter piston 1 1/16" diameter double heat treated pinion journal 	Arms	Regular Arm
Fluid	All weather fluid	Finishes/colors/powder coat	<ul style="list-style-type: none"> 622 Matte black 689 Aluminum 690 Statuary bronze 691 Light bronze 693 Gloss black 695 Dark bronze 696 Brass Custom colors optional
Handing	Handed		<ul style="list-style-type: none"> Optional SRI primer - powder coat only Optional plated finishes
Size	Sized 1-6		
Warranty	15 years		
Fasteners	Wood screws and torx security screws (optional)		

Product configurations

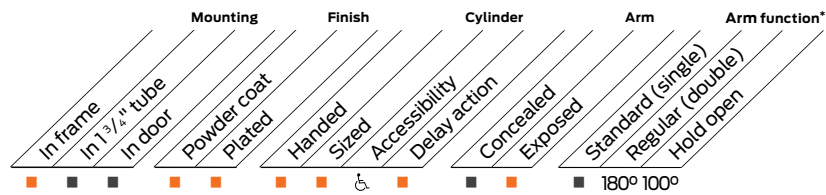

■ Available
■ Not available

Closer available with less than 5.0 lbs. opening force on 36" door.

* Maximum opening/Hold open point with standard template. See individual closer series for degrees of opening per installation.

Customized installation templates or products may be available to solve non-standard applications. Contact LCN Product Support for assistance.

Mounting details

Concealed mounting

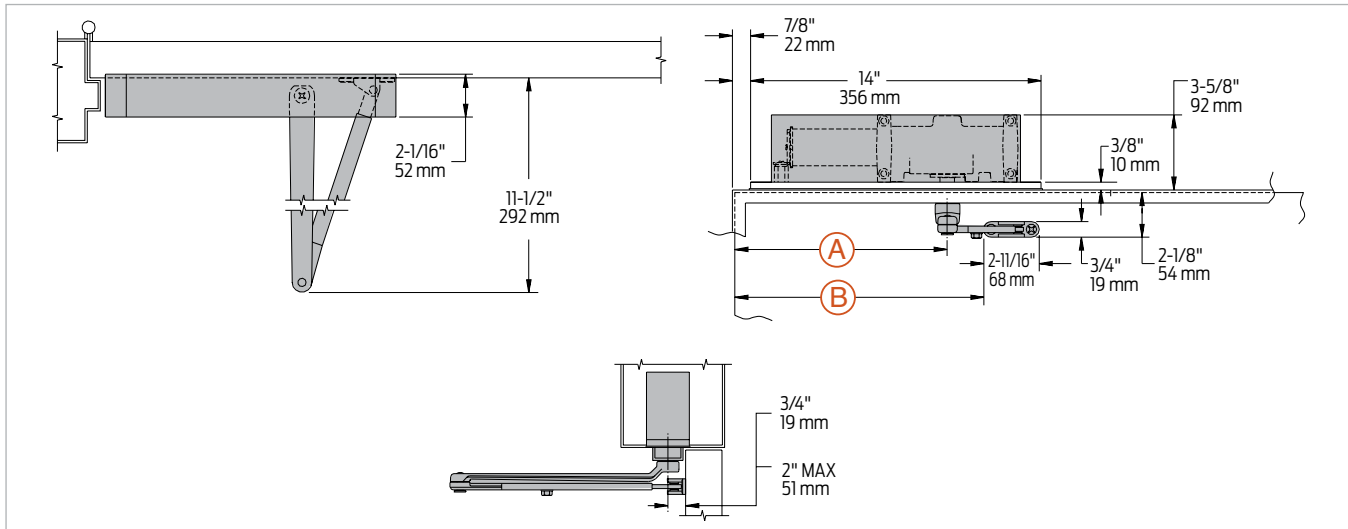

Butt hinges	Should not exceed 6" (152 mm) in width
Auxiliary stop	Recommended at Hold open point or where a door cannot swing 180°
Top rail	Minimum 2 1/8" (54 mm) required
Delay action	<ul style="list-style-type: none"> ▪ Add suffix "CYLDEL" to selected cylinder (not available with 5016 cylinder) ▪ Delays closing from maximum opening to approximately 70° ▪ Delay time adjustable up to approximately 1 minute
Maximum opening	<p>Butt hung doors can be templated for:</p> <p>100°: A = 10 3/16" (259 mm) B = 12" (305 mm)</p> <p>180°: A = 5 1/2" (140 mm) B = 7 5/16" (186 mm) trim permitting</p> <ul style="list-style-type: none"> ▪ Hold open points up to 100° only with Hold open arm (H) ▪ Center pivot mounting restricts opening to 140° ▪ Offset pivot mounting allows up to 180°, trim permitting

Notes:

- For interior or exterior doors
- Single acting cylinder in head frame
- Exposed arm on hinge side of door

5010 Series

Accessories

Cylinders

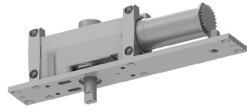

**5011(2)(3)(4)(5)(6)-3071
Cast iron cylinder assembly
with mounting plate (CYL)**

- Handed
- With mounting plate
- Standard

Arms



**5010-3077
Regular arm (REGARM)**

- Non-handed



**5010-3049
Hold open arm (H)**

- Handed
- Provides hold open function for 100° template, adjustment at elbow
- Optional

Ordering information

How-to-order 5010 Series closers

1. Select cylinder size

- 5011
- 5012
- 5013
- 5014
- 5015
- 5016 (CYLDEL not available)

2. Specify hand

- Right hand (RH)
- Left hand (LH)

3. Select finish

- Standard powder coat _____
Matte black (622), Aluminum (689), Dark bronze (695), Statuary bronze (690), Light bronze (691), Gloss black (693), or Brass (696)

Closer will be shipped with:

- Standard cylinder with finish plate
- Standard arm
- Regular arm
- Wood and machine screws
(unless options listed below are selected)

Closer options

Cylinder function

- Delay action cylinder (CYLDEL)

Arm

- Hold open arm (H)

Finish

- Custom powder coat (RAL) _____
- Plated finish _____
- SRI primer (use with powder coat finishes only)

Screw pack

- Torx machine screws (TORX)

Special template

- ST- _____

Table of sizes

- Select closer based on width of door
- Series cylinders available in size 1, 2, 3, 4, 5 or 6
- Closing power of all 5010 Series closers may be increased 50%
- Specify next higher size closer where strong drafts exist
- Delay action not available with 5016 cylinder

Exterior (and vestibule) door width

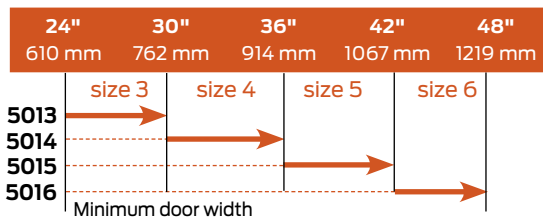

Interior door width

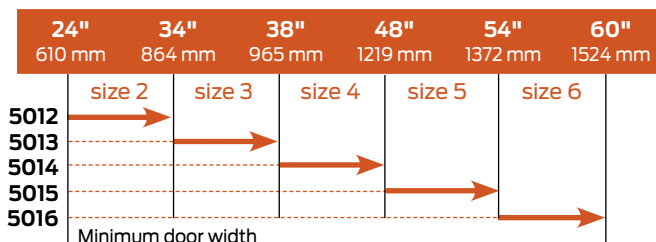

→ Indicates recommended range of door width for closer size.

Reduced opening force 5010 Series closers

CAUTION! Any manual door closer, including those certified by BHMA to conform to ANSI Standard A156.4, that is selected, installed and adjusted based on ADA or other reduced opening force requirements may not provide sufficient power to reliably close and latch a door.

Refer to Automatic Operators catalog for information on systems that meet reduced opening force requirements without effecting closing power.

	Door width	36"	42"	48"
	8.5* lbs.	5012	5013	5013
	5.0* lbs.	5011	5011	5012

* Maximum opening force.

5030 Series



The concealed 5030 Series PACER[®] is a heavy duty closer designed to fit in a narrow, minimum 1 3/4" aluminum transom. The double lever arm provides superior door control and the choice of finishes and arm functions meet virtually all architectural requirements.

Features

Certifications	ANSI/BHMA A156.4, UL 10C, ADA, 100 hour salt spray, meets BAA - Buy American Act
Body construction	<ul style="list-style-type: none"> Cast iron body Full complement bearing 1 1/8" diameter piston 11/16" diameter double heat treated pinion journal
Fluid	All weather fluid
Handing	Handed
Size	Sized 1, 3, 4, 5, 6
Warranty	15 years

Fasteners	Wood screws and torx security screws (optional)
Mounting	Concealed (in tube); aluminum frame requires minimum 1 3/4" (44 mm) x 4 1/2" (114 mm) tube
Arms	Regular arm
Finishes/colors/ powder coat	<ul style="list-style-type: none"> 622 Matte black 689 Aluminum 690 Statuary bronze 691 Light bronze 693 Gloss black 695 Dark bronze 696 Brass Custom colors optional <ul style="list-style-type: none"> Optional SRI primer - powder coat only Optional plated finishes

Product configurations

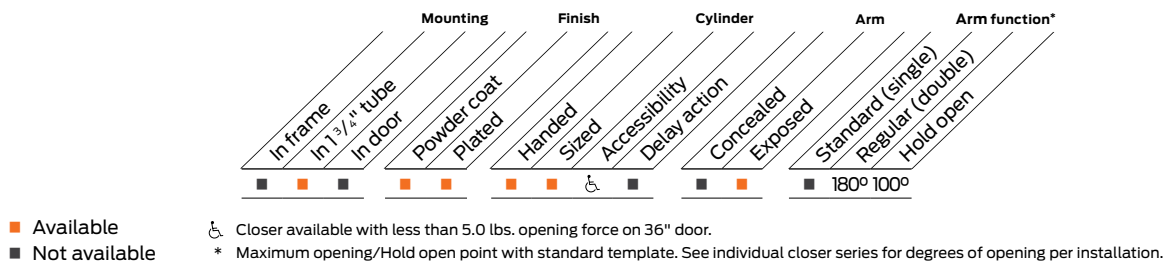

Customized installation templates or products may be available to solve non-standard applications. Contact LCN Product Support for assistance.

Mounting details

Concealed mounting

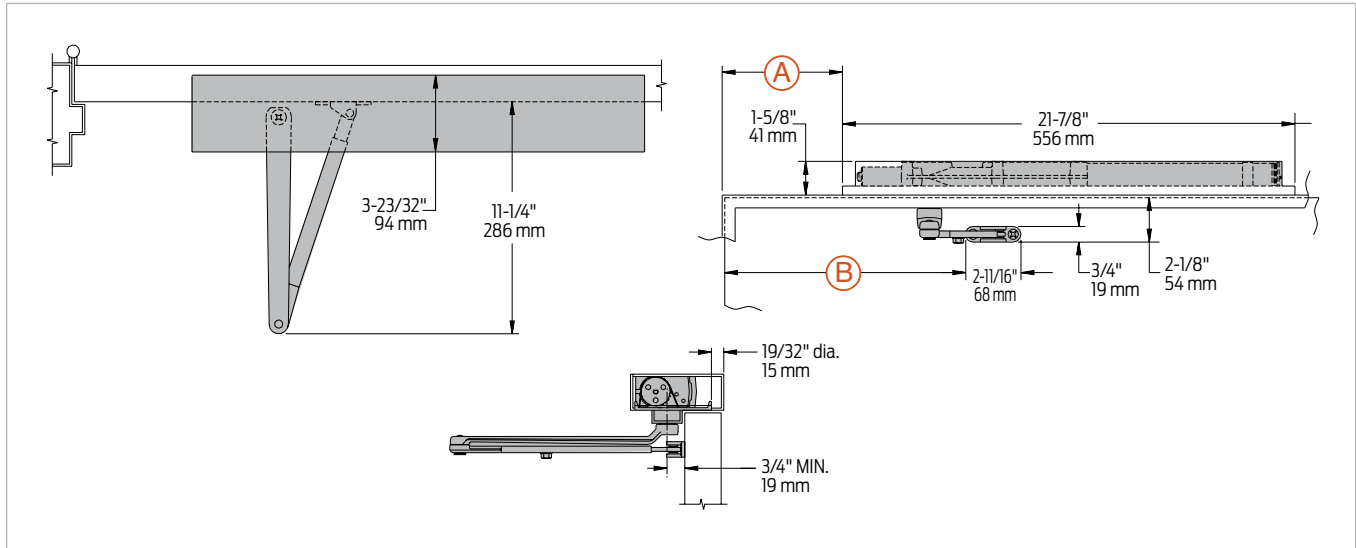

Butt hinges	Should not exceed 6" (152 mm) in width
Auxiliary stop	Recommended at Hold open point or where the door cannot swing 180°
Top rail	Minimum 2 1/8" (54 mm) required
Door thickness	Maximum 1 3/4" (44 mm), for doors thicker than 1 3/4" consult factory
Wood frame	<ul style="list-style-type: none"> Installation simplified by wood mounting clip set 5030-416 for center pivoted or 5030-417 for offset pivoted and butt hung installations Consult factory for preparation details
Maximum opening	<p>Butt hung doors can be templated for:</p> <p>100°: A = 5 13/16" (148 mm) B = 11 13/16" (300 mm)</p> <p>180°: A = 2 1/16" (52 mm) B = 8 1/16" (205 mm) trim permitting</p> <ul style="list-style-type: none"> Hold open points up to 100° only with Hold open arm (H) Center pivot mounting restricts opening to 120°. Hold open up to 120° with Hold open Arm (H) Offset pivot mounting allows up to 115°, trim permitting. Hold open up to 115° with Hold open Arm (H)

- Notes:
- For interior or exterior doors
 - Single acting cylinder in head frame
 - Exposed arm on push side of door

5030 Series

Accessories

Cylinders



5011(2)(3)(4)(5)(6)-3071 Cast iron cylinder assembly with mounting plate (CYL)

- Handed
- With mounting plate
- Standard

Arms



5010-3077 Regular arm (REGARM)

- Non-handed



5030-3049 Hold open arm (H)

- Handed
- Provides hold open function for 100° template, adjustment at elbow
- Optional

Installation accessories

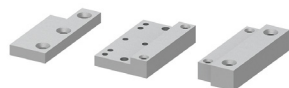

5030-416 Wood mounting clip set

- Simplifies mounting center pivoted 5030 closer in wood frame
- Includes latch stile clip, hinge stile clip and cover
- For use with Ives center pivots
- Consult factory for special template



5030-417 Wood mounting clip set

- Simplifies mounting offset pivoted or butt hung 5030 closer in wood frame
- Includes two clips
- For use with offset pivots
- Consult factory for special template

Ordering information

How-to-order 5030 Series closers

1. Select cylinder size

- 5031
- 5033
- 5034
- 5035
- 5036

2. Specify hand

- Right hand (RH)
- Left hand (LH)

3. Select finish

- Standard powder coat _____
Matte black (622), Aluminum (689), Dark bronze (695), Statuary bronze (690), Light bronze (691), Gloss black (693), or Brass (696)

Closer will be shipped with:

- Standard cylinder with mounting plate
- Regular arm
- Wood and machine screws
(unless options listed below are selected)

Closer options

Arm

- Hold open Arm (H)

Finish

- Custom powder coat (RAL) _____
- Plated finish _____
- SRI primer (use with powder coat finishes only)

Screw pack

- Torx machine screws (TORX)

Installation accessories

- Wood clip set, 5030-416
- Wood clip set, 5030-417

Special template

- ST- _____

Table of sizes

- Select closer based on width of door
- 5030 Series cylinders available in size 1, 2, 3, 4, 5 or 6
- Closing power of all 5030 Series closers may be increased 50%
- Specify next higher size closer where strong drafts exist

Exterior (and vestibule) door width

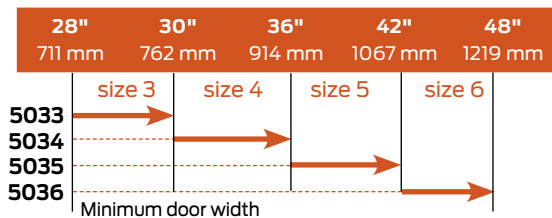

Interior door width

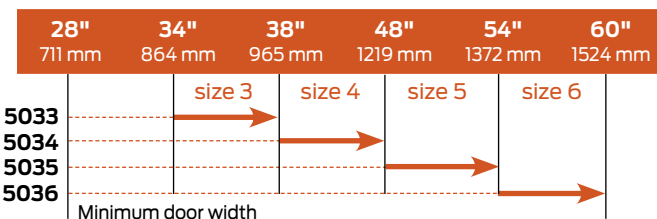

→ Indicates recommended range of door width for closer size.

Reduced opening force 5030 Series closers

CAUTION! Any manual door closer, including those certified by BHMA to conform to ANSI Standard A156.4, that is selected, installed and adjusted based on ADA or other reduced opening force requirements may not provide sufficient power to reliably close and latch a door.

Refer to Automatic Operators catalog for information on systems that meet reduced opening force requirements without effecting closing power.

	Door width	36"	42"	48"
	8.5* lbs.	5033	5033	5033
	5.0* lbs.	5031	5031	5033

* Maximum opening force.

6030 Series

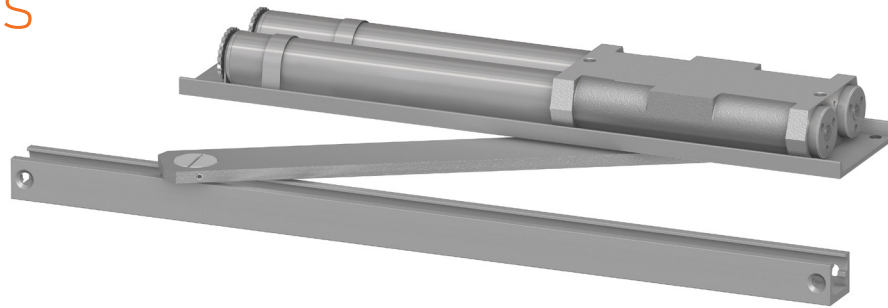

The concealed 6030 Series PACER® is a heavy duty double acting closer designed to fit in a narrow, minimum 1 3/4" header. The single lever arm and roller assembly provides smooth, quiet door control and the choice of finishes and track functions meet virtually all architectural requirements.

Features

Certifications	ANSI/BHMA A156.4, UL 10C, ADA, 100 hour salt spray, meets BAA - Buy American Act
Body construction	<ul style="list-style-type: none"> ▪ Cast iron body ▪ Full complement bearing ▪ 1 1/8" diameter piston ▪ 1/16" diameter double heat treated pinion journal
Fluid	All weather fluid
Handing	Non-handed
Size	Sized 1-5
Warranty	15 years

Fasteners	Wood screws and torx security screws (optional)
Mounting	Concealed (in tube); double acting
Arms	Standard arm with track
Finishes/colors/ powder coat	<ul style="list-style-type: none"> ▪ 622 Matte black ▪ 689 Aluminum ▪ 690 Statuary bronze ▪ 691 Light bronze ▪ 693 Gloss black ▪ 695 Dark bronze ▪ 696 Brass ▪ Custom colors optional
	<ul style="list-style-type: none"> ▪ Optional SRI primer - powder coat only ▪ Optional plated finishes

Product configurations

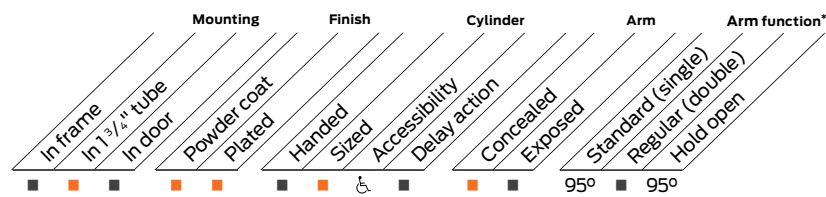

■ Available
■ Not available

Closer available with less than 5.0 lbs. opening force on 36" door.

* Maximum opening/Hold open point with standard template. See individual closer series for degrees of opening per installation.

Customized installation templates or products may be available to solve non-standard applications. Contact LCN Product Support for assistance.

Mounting details

Hinge (pull) side mounting

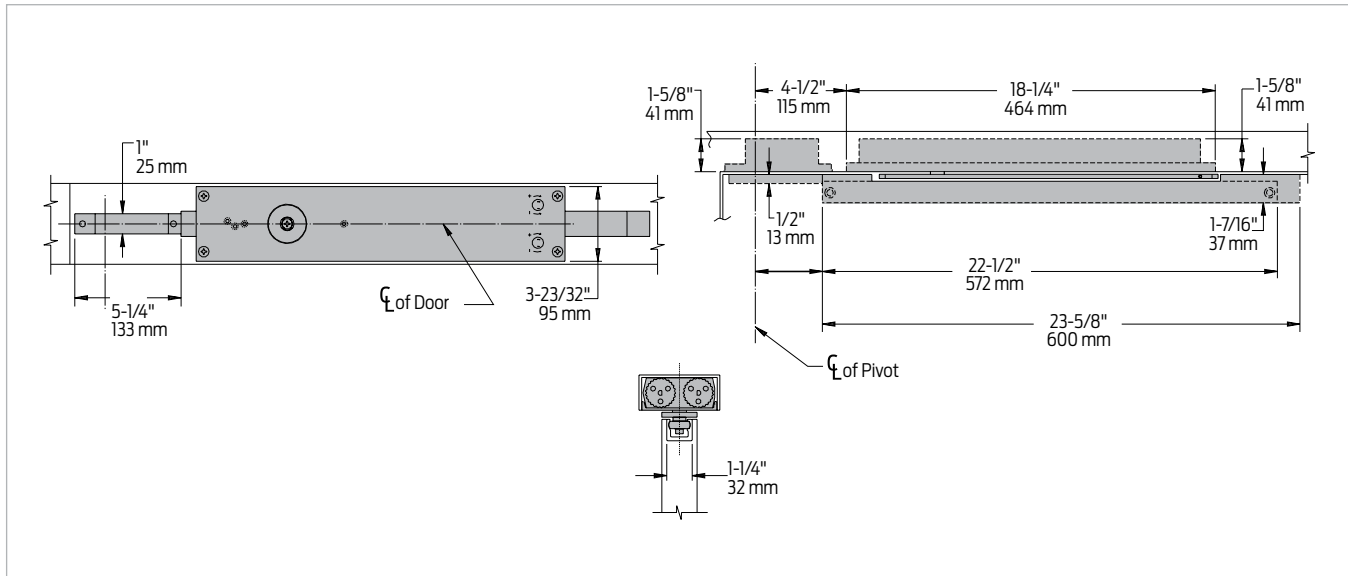

Auxiliary stop	Recommended where a door cannot swing 95°
Center pivot set	Must be used but ordered separately
Top rail	<ul style="list-style-type: none"> 1 7/16" (36 mm) mortise required 3/8" (10 mm) cutout required at top of the door, both sides
Door thickness	1 3/4" (44 mm) minimum
Door width	30" (762 mm) minimum with 1 3/4" (44 mm) pivot centers
Centering adjustment	Centering is provided by rotating the track roller to center the door in the opening
Wood frame	<ul style="list-style-type: none"> Installation simplified by wood mounting clip set, 6030-416 Consult product support for special template
Maximum opening	<ul style="list-style-type: none"> Center pivot template allows 95° Adjustable Hold open points from 85° to 95° with Hold open track (H)

Notes:

- For interior or exterior doors
- Double acting cylinder in cased frame
- Concealed arm and track in door top rail
- Center pivots only

Accessories

Cylinders



- 6031(2)(3)(4)(5)-3071**
Cast iron cylinder assembly with mounting plate (CYL)
- Non-handed
 - With mounting plate
 - Standard

Arms



- 6030-3077T**
Standard arm (STDTRKARM)
- Non-handed
 - 3/16" (8 mm) thick arm
 - Track roller not included with arm

Tracks



- 6030-3038B**
Track with bumper (BUMP)
- Non-handed
 - Non hold open
 - Will accept hold open clip
 - Standard



- 6030-3038HB**
Hold open track with bumper (HBMP)
- Non-handed
 - Optional

Installation accessories

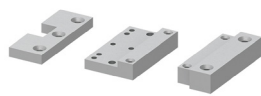

- 6030-416**
Wood mounting clip set
- Simplifies mounting closer in wood frame
 - Includes latch stile clip, hinge stile clip and cover
 - For use with Ives center pivots
 - Consult factory for special template



- 6030-169**
Track bumper
- Mounts to track to assist back check
 - Limits maximum opening
 - Consists of bumper, bumper post, and mounting screw

Note: Track bumper does not replace auxiliary stop.

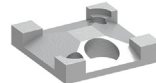

- 6030-3034**
Track roller
- Quiet, low friction roller assembly includes eccentric with 3/4" (19 mm) adjustment to center 36" (914 mm) door



- 6030-3034**
Track roller
- Quiet, low friction roller assembly includes eccentric with 3/4" (19 mm) adjustment to center 36" (914 mm) door



- 6030-3034H**
Hold open track roller
- Hold open roller
 - Quiet, low friction roller assembly

Ordering information

How-to-order 6030 Series closers

1. Select cylinder size

- 6031
- 6032
- 6033
- 6034
- 6035

2. Select finish

- Standard powder coat _____
- Matte black (622), Aluminum (689), Dark bronze (695), Statuary bronze (690), Light bronze (691), Gloss black (693), or Brass (696)

Closer will be shipped with:

- Standard cylinder with mounting plate
- Standard arm
- Standard Track with bumper
- Wood and machine screws
(unless options listed below are selected)

Closer options

Track

- Hold open Track with bumper (HBMP)

Finish

- Custom powder coat (RAL) _____
- Plated finish _____
- SRI primer (use with powder coat finishes only)

Screw pack

- Torx machine screws (TORX)

Installation accessories

- Wood clip set, 6030-416

Special template

- ST- _____

Table of sizes

- Select closer based on width of door
- 6030 Series cylinders available in size 1, 2, 3, 4, or 5
- Closing power of all 6030 Series closers may be increased 35%
- Specify next higher size closer where strong drafts exist

Exterior (and vestibule) door width

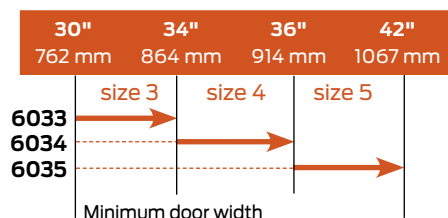

Interior door width

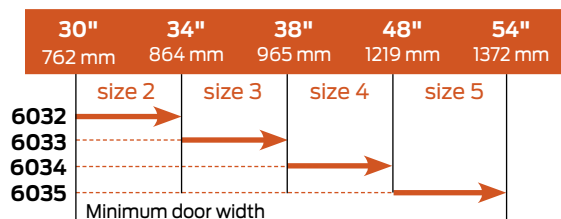

→ Indicates recommended range of door width for closer size.
Note: Minimum door width 28" (711 mm).

Reduced opening force 6030 Series closers

CAUTION! Any manual door closer, including those certified by BHMA to conform to ANSI Standard A156.4, that is selected, installed and adjusted based on ADA or other reduced opening force requirements may not provide sufficient power to reliably close and latch a door.

Refer to Automatic Operators catalog for information on systems that meet reduced opening force requirements without effecting closing power.

	Door width	36"	42"	48"
	8.5* lbs.	6033	6034	6035
	5.0* lbs.	6031	6032	6032

* Maximum opening force.

About Allegion

At Allegion (NYSE: ALLE), we design and manufacture innovative security and access solutions that help keep people safe where they live, learn, work and connect. We're pioneering safety with our strong legacy of brands like CISA®, Interflex®, LCN®, Schlage®, SimonsVoss® and Von Duprin®. Our comprehensive portfolio of hardware, software and electronic solutions is sold around the world and spans residential and commercial locks, door closer and exit devices, steel doors and frames, access control and workforce productivity systems.

For more, visit www.allegion.com

KRYPTONITE ■ LCN ■  ■ STEELCRAFT ■ VON DUPRIN