

# BYP-100A Series

## Aluminum track hardware for 100 lb by-pass doors.



Hardware for mid to heavy-weight two panel by-pass doors. The BYP-100A series features adjustable door guides and 4-wheel carriers for smooth door movement. Ideal for 100 lb by-pass doors used in commercial and residential interior closets, pantries, and room dividers.

Door thickness: 1-3/8" to 1-3/4"

Load rating: Up to 100 lbs per door

Track: Double aluminum box track

Carrier: 4-wheel ball bearing

Compares to: Hettich/Grant 6064, Stanley BP75-02

Conforms to: ANSI/BHMA A156.14-2007  
Grade 1, D8741, D8742

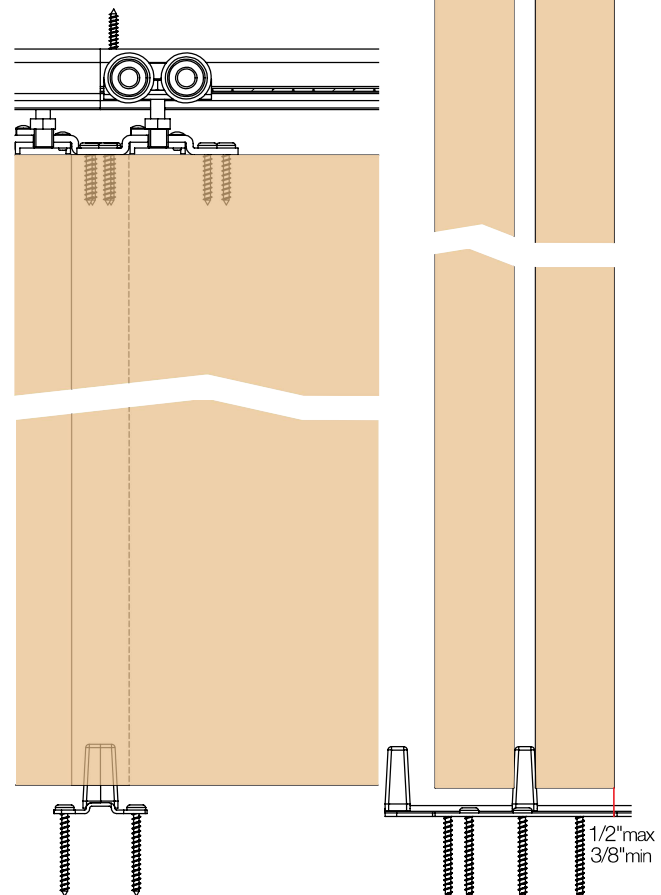
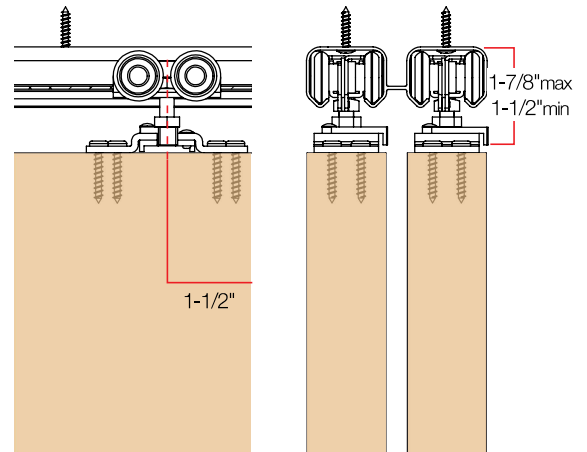

### BYP-100A series configuration

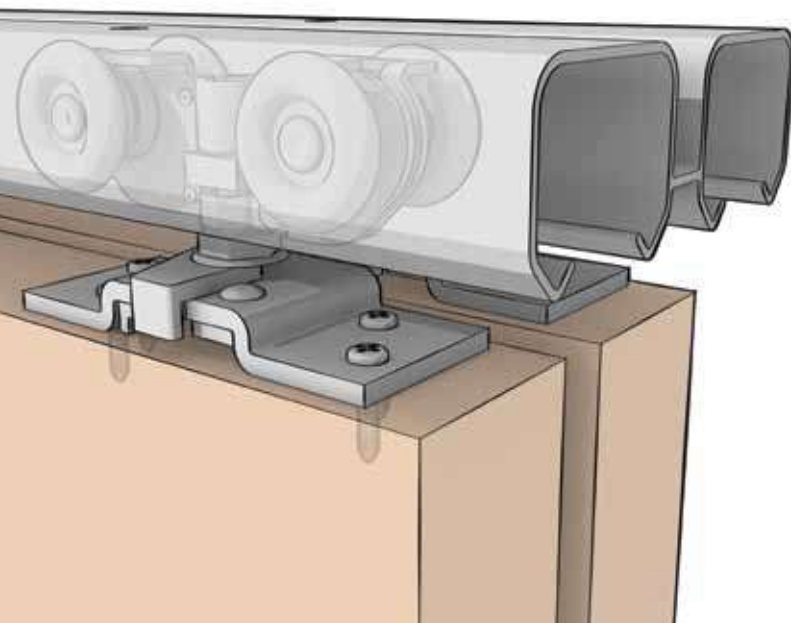

Door Thickness:  
1-3/8" – 1-3/4"

50 60 75 **100** 125 150 175 250 275

By-Pass Door Weight (Lb)

BYP-50S | BYP-60S | 60A | 60AFR | 60AFS | 60AFS3 | 60SW | 60AFW | BYP-75AFW | 75S | 75A

**BYP-100A** | BYP-125A | BYP-150A | BYP-250A | BYP-175I | 275I | Components

## Packaged Sets

SKU	Door Panel Configuration	Pack Qty	Pack Qty Weight (Lb)
BYP-100A-2D-4	2 x 24" doors	5	18
BYP-100A-2D-5	2 x 30" doors	5	21
BYP-100A-2D-6	2 x 36" doors	5	23
BYP-100A-2D-8	2 x 48" doors	5	28

Hardware Contents	BYP-100A-2D-4	BYP-100A-2D-5	BYP-100A-2D-6	BYP-100A-2D-8
Track	1602-46"	1602-58"	1602-70"	1602-94"
Door stop-0880	1	1	1	1
Finger pull-0684-US15P	2	2	2	2
Door guide-0909	1	1	1	1
Quick release top mount plate-1800-DBA	4	4	4	4
Wrench-8665	1	1	1	1
4-wheel ball bearing carriers-1606-QR	4	4	4	4
Screws	Yes	Yes	Yes	Yes



**BYP-100A-2D**

## Tracks

SKU	Description	Pack Qty	Pack Qty Weight (Lb)
BK-1602-46	46" Aluminum track	5	10
BK-1602-58	58" Aluminum track	5	12
BK-1602-70	70" Aluminum track	5	15
BK-1602-94	94" Aluminum track	5	20
BK-1602-118	118" Aluminum track	5	23
BK-1602-142	142" Aluminum track	5	30
Fascia with Header			
BK-1709-72	72" Aluminum fascia	10	17
BK-1709-96	96" Aluminum fascia	10	22

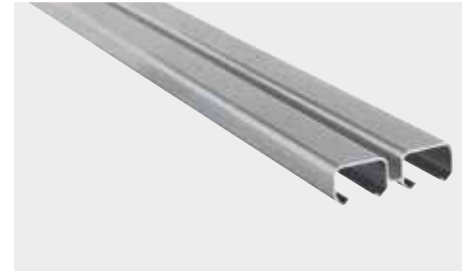

BK-1602 aluminum tracks



BK-1709 aluminum fascia

## Part Bags

SKU	Door Panels	Pack Qty	Pack Qty Weight (Lb)
PB-BYP-100-2	2	10	10

Hardware Contents	PB-BYP-100-2
Door stop-0880	1
Finger pull-0864-US15	2
Door guide-0909	1
Quick release top mount plate-1800-DBA	4
Wrench-8665	1
4-wheel ball bearing carrier-1606-QR	4
Screws	Yes



PB-BYP-100-2

Door Thickness:  
1-3/8" – 1-3/4"

50 60 75 **100** 125 150 175 250 275

By-Pass Door Weight (Lb)

BYP-50S | BYP-60S | 60A | 60AFR | 60AFS | 60AFS3 | 60SW | 60AFW | BYP-75AFW | 75S | 75A

**BYP-100A** | BYP-125A | BYP-150A | BYP-250A | BYP-175I | 275I | Components

## Components

SKU	Description	Pack Qty	Pack Qty Weight (Lb)
BK-0351	Non-adjustable door guide	50	3
BK-0351-WT	Non-adjustable door guide (white)	50	3
BK-0354	3/4" riser, fits 0351 and 0353	50	6
BK-0864-US3	3/4" finger pull (bright brass)	100	1
BK-0865-WT	1-3/4" finger pull (white)	100	2
BK-1606-QR	4-wheel ball bearing carrier, 7/8" diameter wheels	20	4
BK-1800-DBA	Quick release top mount plate	20	2
BN-0353	Adjustable door guide, 3/4" to 1-3/8"	100	4
BN-0868-US10B	2-1/8" finger pull (oil rubbed bronze)	150	5
BN-0868-US15	2-1/8" finger pull (satin nickel)	150	5
BN-0868-US26	2-1/8" finger pull (bright chrome)	150	5
BN-0868-US3	2-1/8" finger pull (bright brass)	150	5
BN-0868-US5	2-1/8" finger pull (antique brass)	150	5
BN-0880	Angle door stop	100	6
PB-0909	Guide for 2 doors from 3/4" to 1-3/4"	20	4
PB1068-26DA	Sliding door lock, nickel, keyed alike	5	2
PB1068-US26D	Sliding door lock, nickel, keyed different	5	2
PB1068-US3	Sliding door lock, brass, keyed different	5	2
PB1068-US3A	Sliding door lock, brass, keyed alike	5	2

