

Fire Alarm Communicator 411UDAC Manual

Document 51073
9/20/2013

Rev: **E**

P/N 51073-E

ECN 13-786

Fire Alarm & Emergency Communication System Limitations

While a life safety system may lower insurance rates, it is not a substitute for life and property insurance!

An automatic fire alarm system—typically made up of smoke detectors, heat detectors, manual pull stations, audible warning devices, and a fire alarm control panel (FACP) with remote notification capability—can provide early warning of a developing fire. Such a system, however, does not assure protection against property damage or loss of life resulting from a fire.

An emergency communication system—typically made up of an automatic fire alarm system (as described above) and a life safety communication system that may include an autonomous control unit (ACU), local operating console (LOC), voice communication, and other various interoperable communication methods—can broadcast a mass notification message. Such a system, however, does not assure protection against property damage or loss of life resulting from a fire or life safety event.

The Manufacturer recommends that smoke and/or heat detectors be located throughout a protected premises following the recommendations of the National Fire Protection Association Standard 72 (NFPA 72), manufacturer's recommendations, State and local codes, and the recommendations contained in the Guide for Proper Use of System Smoke Detectors, which is made available at no charge to all installing dealers. This document can be found at <http://www.systemsensor.com/appguides/>. A study by the Federal Emergency Management Agency (an agency of the United States government) indicated that smoke detectors may not go off in as many as 35% of all fires. While fire alarm systems are designed to provide early warning against fire, they do not guarantee warning or protection against fire. A fire alarm system may not provide timely or adequate warning, or simply may not function, for a variety of reasons:

Smoke detectors may not sense fire where smoke cannot reach the detectors such as in chimneys, in or behind walls, on roofs, or on the other side of closed doors. Smoke detectors also may not sense a fire on another level or floor of a building. A second-floor detector, for example, may not sense a first-floor or basement fire.

Particles of combustion or "smoke" from a developing fire may not reach the sensing chambers of smoke detectors because:

- Barriers such as closed or partially closed doors, walls, chimneys, even wet or humid areas may inhibit particle or smoke flow.
- Smoke particles may become "cold," stratify, and not reach the ceiling or upper walls where detectors are located.
- Smoke particles may be blown away from detectors by air outlets, such as air conditioning vents.
- Smoke particles may be drawn into air returns before reaching the detector.

The amount of "smoke" present may be insufficient to alarm smoke detectors. Smoke detectors are designed to alarm at various levels of smoke density. If such density levels are not created by a developing fire at the location of detectors, the detectors will not go into alarm.

Smoke detectors, even when working properly, have sensing limitations. Detectors that have photoelectronic sensing chambers tend to detect smoldering fires better than flaming fires, which have little visible smoke. Detectors that have ionizing-type sensing chambers tend to detect fast-flaming fires better than smoldering fires. Because fires develop in different ways and are often unpredictable in their growth, neither type of detector is necessarily best and a given type of detector may not provide adequate warning of a fire.

Smoke detectors cannot be expected to provide adequate warning of fires caused by arson, children playing with matches (especially in bedrooms), smoking in bed, and violent explosions

(caused by escaping gas, improper storage of flammable materials, etc.).

Heat detectors do not sense particles of combustion and alarm only when heat on their sensors increases at a predetermined rate or reaches a predetermined level. Rate-of-rise heat detectors may be subject to reduced sensitivity over time. For this reason, the rate-of-rise feature of each detector should be tested at least once per year by a qualified fire protection specialist. Heat detectors are designed to protect property, not life.

IMPORTANT! Smoke detectors must be installed in the same room as the control panel and in rooms used by the system for the connection of alarm transmission wiring, communications, signaling, and/or power. If detectors are not so located, a developing fire may damage the alarm system, compromising its ability to report a fire.

Audible warning devices such as bells, horns, strobes, speakers and displays may not alert people if these devices are located on the other side of closed or partly open doors or are located on another floor of a building. Any warning device may fail to alert people with a disability or those who have recently consumed drugs, alcohol, or medication. Please note that:

- An emergency communication system may take priority over a fire alarm system in the event of a life safety emergency.
- Voice messaging systems must be designed to meet intelligibility requirements as defined by NFPA, local codes, and Authorities Having Jurisdiction (AHJ).
- Language and instructional requirements must be clearly disseminated on any local displays.
- Strobes can, under certain circumstances, cause seizures in people with conditions such as epilepsy.
- Studies have shown that certain people, even when they hear a fire alarm signal, do not respond to or comprehend the meaning of the signal. Audible devices, such as horns and bells, can have different tonal patterns and frequencies. It is the property owner's responsibility to conduct fire drills and other training exercises to make people aware of fire alarm signals and instruct them on the proper reaction to alarm signals.
- In rare instances, the sounding of a warning device can cause temporary or permanent hearing loss.

A life safety system will not operate without any electrical power. If AC power fails, the system will operate from standby batteries only for a specified time and only if the batteries have been properly maintained and replaced regularly.

Equipment used in the system may not be technically compatible with the control panel. It is essential to use only equipment listed for service with your control panel.

Telephone lines needed to transmit alarm signals from a premises to a central monitoring station may be out of service or temporarily disabled. For added protection against telephone line failure, backup radio transmission systems are recommended.

The most common cause of life safety system malfunction is inadequate maintenance. To keep the entire life safety system in excellent working order, ongoing maintenance is required per the manufacturer's recommendations, and UL and NFPA standards. At a minimum, the requirements of NFPA 72 shall be followed. Environments with large amounts of dust, dirt, or high air velocity require more frequent maintenance. A maintenance agreement should be arranged through the local manufacturer's representative. Maintenance should be scheduled monthly or as required by National and/or local fire codes and should be performed by authorized professional life safety system installers only. Adequate written records of all inspections should be kept.

Limit-D-1-2013

Installation Precautions

Adherence to the following will aid in problem-free installation with long-term reliability:

WARNING - Several different sources of power can be connected to the fire alarm control panel. Disconnect all sources of power before servicing. Control unit and associated equipment may be damaged by removing and/or inserting cards, modules, or interconnecting cables while the unit is energized. Do not attempt to install, service, or operate this unit until manuals are read and understood.

CAUTION - System Re-acceptance Test after Software Changes: To ensure proper system operation, this product must be tested in accordance with NFPA 72 after any programming operation or change in site-specific software. Re-acceptance testing is required after any change, addition or deletion of system components, or after any modification, repair or adjustment to system hardware or wiring. All components, circuits, system operations, or software functions known to be affected by a change must be 100% tested. In addition, to ensure that other operations are not inadvertently affected, at least 10% of initiating devices that are not directly affected by the change, up to a maximum of 50 devices, must also be tested and proper system operation verified.

This system meets NFPA requirements for operation at 0-49° C/32-120° F and at a relative humidity . However, the useful life of the system's standby batteries and the electronic components may be adversely affected by extreme temperature ranges and humidity. Therefore, it is recommended that this system and its peripherals be installed in an environment with a normal room temperature of 15-27° C/60-80° F.

Verify that wire sizes are adequate for all initiating and indicating device loops. Most devices cannot tolerate more than a 10% I.R. drop from the specified device voltage.

Like all solid state electronic devices, this system may operate erratically or can be damaged when subjected to lightning induced transients. Although no system is completely immune from lightning transients and interference, proper grounding will reduce susceptibility. Overhead or outside aerial wiring is not recommended, due to an increased susceptibility to nearby lightning strikes. Consult with the Technical Services Department if any problems are anticipated or encountered.

Disconnect AC power and batteries prior to removing or inserting circuit boards. Failure to do so can damage circuits.

Remove all electronic assemblies prior to any drilling, filing, reaming, or punching of the enclosure. When possible, make all cable entries from the sides or rear. Before making modifications, verify that they will not interfere with battery, transformer, or printed circuit board location.

Do not tighten screw terminals more than 9 in-lbs. Overtightening may damage threads, resulting in reduced terminal contact pressure and difficulty with screw terminal removal.

This system contains static-sensitive components.

Always ground yourself with a proper wrist strap before handling any circuits so that static charges are removed from the body. Use static suppressive packaging to protect electronic assemblies removed from the unit.

Follow the instructions in the installation, operating, and programming manuals. These instructions must be followed to avoid damage to the control panel and associated equipment. FACP operation and reliability depend upon proper installation.

Precau-D1-9-2005

FCC Warning

WARNING: This equipment generates, uses, and can radiate radio frequency energy and if not installed and used in accordance with the instruction manual may cause interference to radio communications. It has been tested and found to comply with the limits for class A computing devices pursuant to Subpart B of Part 15 of FCC Rules, which is designed to provide reasonable protection against such interference when devices are operated in a commercial environment. Operation of this equipment in a residential area is likely to cause interference, in which case the user will be required to correct the interference at his or her own expense.

Canadian Requirements

This digital apparatus does not exceed the Class A limits for radiation noise emissions from digital apparatus set out in the Radio Interference Regulations of the Canadian Department of Communications.

Le présent appareil numérique n'émet pas de bruits radioélectriques dépassant les limites applicables aux appareils numériques de la classe A prescrites dans le Règlement sur le brouillage radioélectrique édicté par le ministère des Communications du Canada.

HARSH™, NIS™, and NOTI-FIRE-NET™ are all trademarks; and Acclimate® Plus, ECLIPSE®, Filtrex®, FlashScan®, NION®, NOTIFIER®, ONYX®, ONYXWorks®, Pinnacle®, UniNet®, VeriFire®, and VIEW® are all registered trademarks of Honeywell International Inc. Echelon® is a registered trademark and LonWorks™ is a trademark of Echelon Corporation. ARCNET® is a registered trademark of Datapoint Corporation. Microsoft® and Windows® are registered trademarks of the Microsoft Corporation.

©2013. All rights reserved. Unauthorized use of this document is strictly prohibited.

Software Downloads

In order to supply the latest features and functionality in fire alarm and life safety technology to our customers, we make frequent upgrades to the embedded software in our products. To ensure that you are installing and programming the latest features, we strongly recommend that you download the most current version of software for each product prior to commissioning any system. Contact Technical Support with any questions about software and the appropriate version for a specific application.

Documentation Feedback

Your feedback helps us keep our documentation up-to-date and accurate. If you have any comments or suggestions about our online Help or printed manuals, you can email us.

Please include the following information:

- Product name and version number (if applicable)
- Printed manual or online Help
- Topic Title (for online Help)
- Page number (for printed manual)
- Brief description of content you think should be improved or corrected
- Your suggestion for how to correct/improve documentation

Send email messages to:

FireSystems.TechPubs@honeywell.com

Please note this email address is for documentation feedback only. If you have any technical issues, please contact Technical Services.

Table of Contents

Section 1: Product Description	10
1.1: Product Features	10
1.2: Specifications.....	12
1.3: Circuits.....	13
1.3.1: Channels/Inputs	13
1.3.2: Notification Appliance Circuit	13
1.3.3: Output Circuits	13
1.3.4: Auxiliary Relays	13
1.3.5: Earth Ground	13
1.4: Controls and Indicators.....	14
1.5: Components and Accessories	15
1.6: Digital Communicator Operation	15
1.7: Panel Configuration	16
1.8: Operational Modes.....	16
1.8.1: Normal Mode.....	16
1.8.2: Real Time Clock Mode.....	16
1.8.3: Program Mode	16
1.8.4: Troubleshoot Mode.....	16
1.8.5: Default Mode.....	16
1.9: Telephone Requirements and Warnings.....	17
1.9.1: Telephone Circuitry - PH1 & PH2	17
1.9.2: Digital Alarm Communicator:.....	17
1.9.3: Telephone Company Rights and Warnings	17
Section 2: Installation.....	18
2.1: Mounting Options	18
2.2: Mounting.....	18
2.3: Operating Power	20
Primary Power Source (AC) and Earth Ground Connections	20
Secondary Power Source (batteries).....	21
2.4: Input Channels	22
2.5: Output Circuits.....	25
Notification Appliance Circuit	25
Relay Programming.....	26
2.6: Telephone Circuits	27
2.7: Optional Programmer	28
2.8: UL Power-limited Wiring Requirements.....	29
Section 3: Modes of Operation	30
3.1: Normal Mode.....	30
3.1.1: Programmer Key Functions.....	31
MODE KEY	31
LAMP TEST KEY	31
1st EVENT KEY	32
DOWN ARROW	32
UP ARROW	32
ENTER/STORE	32
3.1.2: Programmer Display.....	32
3.2: Password Creation and Entry.....	32
3.3: Real Time Clock Mode.....	33
3.4: Program Mode	34
3.4.1: DACT Programming	36
Primary Central Station Phone Number (00 - 19).....	36
Primary Central Station Number Communication Format (20).....	36
Event Codes - Setting Entries.....	37

Ademco Contact ID Format Primary Central Station Event Codes	37
4+2 Standard and 4+2 Express Formats Primary Central Station Event Codes.....	38
All 3+1, 4+1 and 4+2 Expanded Formats Primary Central Station Event Codes	39
Primary Central Station Number Account Code (21 - 24)	40
Primary Central Station Number 24 Hour Test Time (25 - 28).....	40
Primary Central Station Number 24/12/8/6 Hour Test Time Interval (29)	40
Secondary Central Station Phone Number (30 - 49)	40
Secondary Central Station Number Communication Format (50)	41
Ademco Contact ID Format Secondary Central Station Event Codes	42
4+2 Standard and 4+2 Express Formats Secondary Central Station Event Codes.....	43
All 3+1, 4+1 and 4+2 Expanded Formats Secondary Central Station Event Codes	44
Secondary Central Station Number Account Code (51 - 54)	45
Secondary Central Station Number 24 Hour Test Time (55 - 58).....	45
Secondary Central Station Number 24/12/8/6 Hour Test Time Interval (59)	45
AC Loss Reporting Delay (60).....	45
Backup Reporting (61)	45
Reserved for Future Use (62)	45
DACT Trouble Reminder (63)	45
Operational Mode Selection (64).....	45
Input Channel 1 Function Selection (65).....	46
Input Channel 2 Function Selection (66) ¹	46
Input Channel 3 Function Selection (67) ¹	46
Input Channel 4 Function Selection (68) ¹	46
Input Channel 1 Delay Timer (69 - 71)	46
Input Channel 2 Delay Timer (72 - 74) ²	46
Input Channel 3 Delay Timer (75 - 77)	47
Input Channel 4 Delay Timer (78 - 80) ¹	47
Touchtone/Rotary Select for Primary Phone (81)	47
Make/Break Ratio for Primary Phone (82).....	47
Touchtone/Rotary Select for Secondary Phone (83)	47
Make/Break Ratio for Secondary Phone (84).....	47
Output Relay #1 Enable (85)	47
Output Relay #1 Function Selections (86).....	47
Output Relay #2 Enable (87)	47
Output Relay #2 Function Selections (88).....	47
Reserved for Future Use (89)	48
Panel Unlock (90).....	48
Alarm Verification Enable (91)	48
Silence Inhibit Notification Appliance Circuit (92)	48
Autosilence Notification Appliance Circuit (93).....	48
Restoral Method (94).....	49
Coding, Notification Appliance Circuit (95).....	50
Trouble Call Limit - Dialer Runaway Prevention (96).....	50
Panel Identification Number (97 - 100).....	50
Service Terminal 1 Phone Number (101 - 120).....	51
Ring Count on Primary Phone Line (121 - 122).....	51
FAX/Answer Machine, Primary Phone Line (123).....	51
Service Terminal 2 Phone Number (124 - 143).....	51
Upload/Download Reports Sent to Secondary Central Station Phone #, Backup or Always (144).....	51
Programming Event Code Settings (145 - 312).....	51
3.5: Default Mode	51
3.6: Troubleshoot Mode	52
Channel/Inputs	52
AC Line	52
Notification Appliance Circuit	52
Telephone Line Testing	53

Section 4: Central Station Communications	54
4.1: Transmittal Priorities	57
4.2: Ademco Contact ID Format Event Code Description	57
Section 5: Remote Site Upload/Download.....	60
5.1: General.....	60
5.1.1: Security Features	61
Secret Code Verification	61
Panel Unlock	61
Time-out at 411UDAC.....	61
Callback to Service Terminal	62
Error Checking	62
Central Station Acknowledge.....	62
Data Protection/Integrity	62
5.2: Downloading to the Communicator.....	62
5.3: Uploading From the Communicator.....	62
5.4: Simultaneous Data Transfers	63
Section 6: Battery Calculations	64
6.1: 411UDAC Power Supply.....	65
Appendix A: Programming Sheets.....	66
A.1: Digital Communicator Options Program Sheets	66
A.2: Digital Communicator Options Program Sheet (Factory Defaults).....	68
Appendix B: Event Codes/Transmission Format Programming Sheets	70
B.1: 4+2 Standard & 4+2 Express Formats <u>Primary</u> Central Station	70
B.2: 4+2 Standard & 4+2 Express Formats <u>Secondary</u> Central Station	70
B.3: 4+2 Standard & 4+2 Express Formats <u>Primary</u> Central Station	71
B.4: 4+2 Standard & 4+2 Express Formats <u>Secondary</u> Central Station	71
B.5: All 3+1, All 4+1 and 4+2 Expanded Formats for <u>Primary</u> Central Station	72
B.6: All 3+1, All 4+1 and 4+2 Expanded Formats for <u>Secondary</u> Central Station	72
B.7: All 3+1, All 4+1 and 4+2 Expanded Formats for <u>Primary</u> Central Station (Factory Defaults).....	72
B.8: All 3+1, All 4+1 and 4+2 Expanded Formats for <u>Secondary</u> Central Station (Factory Defaults).....	72
B.9: Ademco Contact ID Format <u>Primary</u> Central Station	73
B.10: Ademco Contact ID Format <u>Secondary</u> Central Station	73
B.11: Ademco Contact ID Format <u>Primary</u> Central Station (Factory Defaults).....	74
B.12: Ademco Contact ID Format <u>Secondary</u> Central Station (Factory Defaults).....	74
Appendix C: Ademco Contact ID Format Event Code Description.....	75
Appendix D: Events and Default Event Codes.....	79
Appendix E: Operational Modes.....	80
Index.....	81

This digital communicator/transmitter has been designed to comply with standards set forth by the following regulatory agencies:

- Underwriters Laboratories
- NFPA National Fire Protection Association

Before proceeding, the installer should be familiar with the following documents.



NFPA Standards

Central Station Signaling Systems Protected Premises Unit (Automatic, Manual and Waterflow)

Proprietary Fire Alarm Systems (Protected Premises Unit)

Remote Station Fire Alarm Systems

Automatic Fire Detectors

Installation, Maintenance and Use of Notification Appliances for Fire Alarm Systems

Inspection, Testing and Maintenance for Fire Alarm Systems



Underwriters Laboratories Documents:

UL 217 Smoke Detectors, Single and Multiple Station

UL 268 Smoke Detectors for Fire Protective Signaling Systems

UL 346 Waterflow Indicators for Fire Protective Signaling Systems

UL 464 Audible Signaling Appliances

UL 521 Heat Detectors for Fire Protective Signaling Systems

UL 864 Standard for Control Units for Fire Protective Signaling Systems

UL 1481 Power Supplies for Fire Protective Signaling Systems

UL 1635 Digital Alarm Communicator System Units

UL 1638 Visual Signaling Appliances

UL 1971 Signaling Devices for Hearing Impaired

Other:

NEC Article 250 Grounding

NEC Article 300 Wiring Methods

NEC Article 760 Fire Protective Signaling Systems

Applicable Local and State Building Codes

Requirements of the Local Authority Having Jurisdiction (LAHJ)

This product has been certified to comply with the requirements in the Standard for Control Units and Accessories for Fire Alarm Systems, UL 864, 9th Edition. Operation of this product with products not tested for UL 864, 9th Edition has not been evaluated. Such operation requires the approval of the local Authority Having Jurisdiction (AHJ).

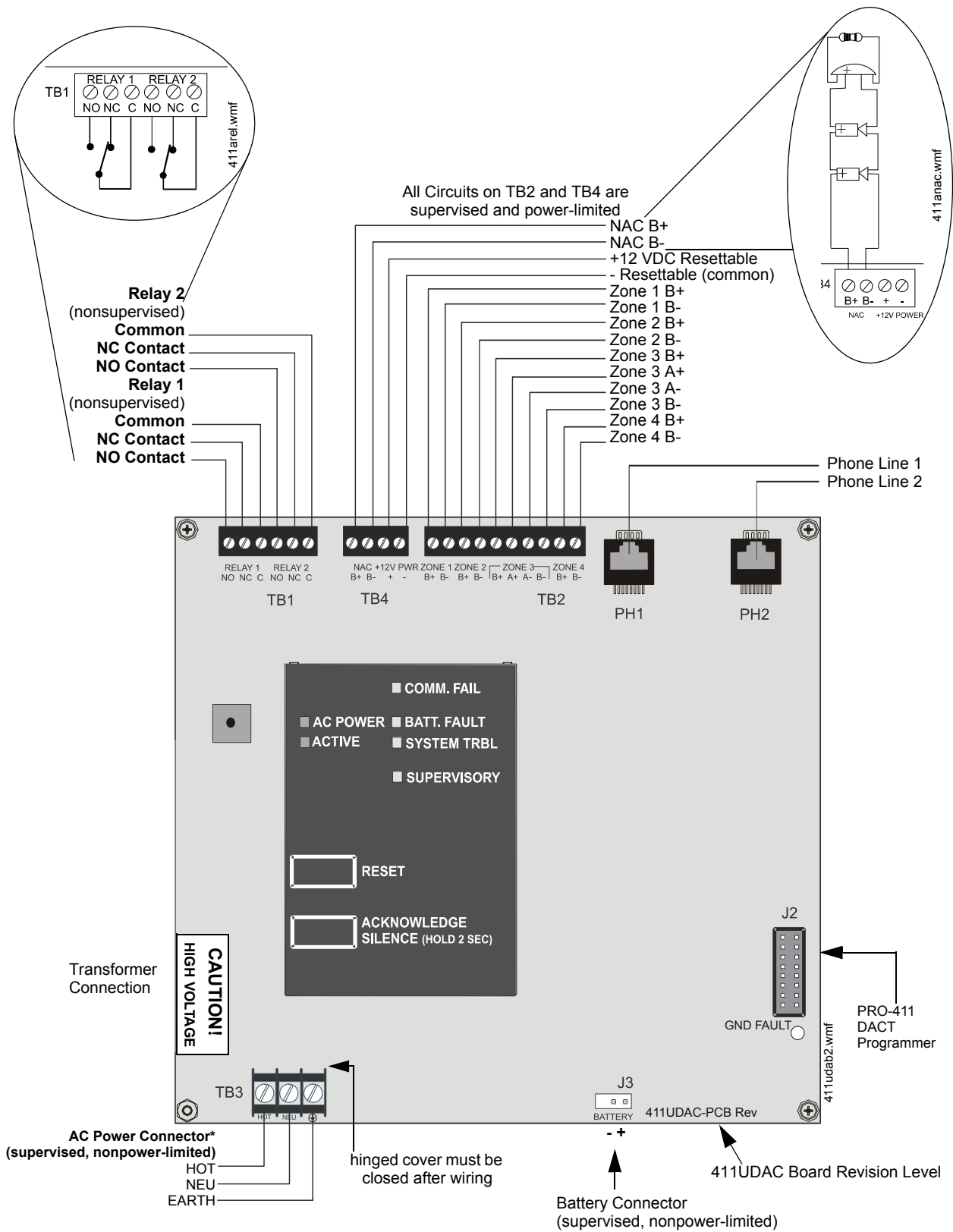

CAUTION: AC POWER TERMINAL LAYOUT CHANGE

USE CAUTION WHEN WIRING AC POWER TO THE 411UDAC AS TERMINAL LAYOUT HAS CHANGED ON TB3!!

Section 1: Product Description

The 411UDAC is a fire alarm communicator with four input/channels and dual telephone lines. The four inputs use conventional input devices. The 411UDAC accepts waterflow devices, four-wire smoke detectors, pull stations and other normally-open contact devices. The unit also supervises AC voltage, telephone line input voltage/current, battery level and battery charger operation.

Outputs include one supplementary NAC (Notification Appliance Circuit), two programmable Form-C relays and 12 VDC resettable special application power. The 411UDAC interfaces with the public switched telephone network and is compatible with most central station receivers. A total of fifteen popular communications formats are supported, including the industry standard Ademco Contact ID. *The communicator also contains a unique DACT option that eliminates 'dialer runaway'. It restricts the transmission of any intermittent nuisance fault to 10 attempts in a 24 hour period.*

Accessories include the Fire-Watch 411 Series DACT Programmer (Model PRO-411) as well as the PK-411UD Windows[®]-based remote site programming software. The 411UDAC is supplied with a compact metal cabinet.

The digital communicator can be programmed or interrogated off-site via the public switched telephone network. Any IBM compatible personal computer with Windows[®] XP or greater, with a 1200 baud Hayes[®] compatible modem and Upload/Download software P/N PK-411UD, may serve as a service terminal.

1.1 Product Features

- Four input/channels - three fixed Style B (Class B) and one Style A (Class A) or Style B (Class B)
- Programmable input channels
 - ✓ 4-wire smoke (Inputs 1 & 3 only)
 - ✓ pull station
 - ✓ normally-open contact
 - ✓ host panel trouble (Slave Mode)
 - ✓ supervisory
 - ✓ supervisory autoresettable
 - ✓ waterflow (silenceable)
 - ✓ waterflow (nonsilenceable)
- One Style Y (Class B) NAC (supplementary application)
- Dual telephone lines
 - ✓ Dual telephone line voltage detect
 - ✓ Alternating phone lines for 24 hour test messages
- 12 VDC operation
- Alarm Verification
- Signal Silence Inhibit
- Autosilence
- Trouble Reminder
- Trouble Resound - troubles will resound the buzzer every 24 hours at midnight until the trouble is cleared
- Optional TR-6 Series Trim Ring
- 20-digit central station and service terminal telephone numbers
- NAC coding per ANSI S-3.41 (Temporal Coding)



Figure 1.1 411UDAC Digital Communicator

- Separate external keypad and display
 - ✓ provides means of programming 411UDAC in program mode
 - ✓ provides means of testing input/output circuits (including telephone connections) in Troubleshoot Mode
- Compact in size 14.5" (36.83 cm) high X 12.875" (32.7 cm) wide X 4.5" (11.43 cm) deep metal cabinet
- Communicates vital status of monitored control panel (Slave Mode):
 - ✓ fire alarm
 - ✓ host control panel trouble
 - ✓ fire supervisory
 - ✓ AC (mains) power loss (programmable)
 - ✓ other
- Communicates vital status of 411UDAC:
 - ✓ digital communicator troubles
 - ✓ telephone Line 1 and 2 voltage fault
 - ✓ Primary Central Station number communication fault
 - ✓ Secondary Central Station number communication fault
 - ✓ system off-normal (local Program Mode entered)
 - ✓ 24 Hour normal test
 - ✓ 24 Hour abnormal test (24 hour test message with previously reported alarm or trouble still active)
- Individual LEDs for:
 - ✓ AC Power
 - ✓ System Trouble
 - ✓ Input Active
 - ✓ Supervisory
 - ✓ Communication Fail
 - ✓ Battery Trouble
 - ✓ Earth Fault
- Local piezo sounder with separate and distinct sounds for the various conditions
- Acknowledge/System Silence switch - 1st press silences local piezo sounder, 2nd press silences NAC
- Reset switch
- Real time clock
- Two Form-C relays, fully programmable to activate for the following conditions:
 - ✓ fire alarm
 - ✓ host control panel trouble
 - ✓ fire supervisory (latching)
 - ✓ fire supervisory (autoresettable)
 - ✓ total communication failure
 - ✓ DACT trouble (factory default for relay)
- Optional PK-411UD Remote Upload/Download Kit
- 'Dialer runaway' feature
- User selectable restoral methods

1.2 Specifications

AC Power - TB3

120 VAC, 60 Hz, 0.7 amps
 Wire size: minimum 14 AWG (2.00 mm²) with 600V insulation
 Supervised, nonpower-limited

Battery (lead acid only) - J3

Maximum Charging Circuit: Float charge - 13.6V @ 3.15 amps
 Maximum Charger Capacity: 14 Amp Hour battery
 Supervised, nonpower-limited

Channels/Inputs - TB2 Terminals 1 through 10

Programmable Channels 1 through 4
 Power-limited circuitry
 Fully supervised (monitored for opens, shorts and earth fault)
 Normal Operating Voltage: 12.0 VDC (ripple = 100 mV maximum)
 End-of-Line Resistor: 2.2K ohms, ½ watt (P/N 27070 UL listed)
 Operation for each channel:

- Channel/Input 1, Style B (Class B) 4-wire smoke detector input and Channel/Input 3, Style B (Class B) 4-wire smoke detectors or waterflows or Style D (Class A) waterflow input:
Connecting 4-wire detectors on Channel/Input 3 requires NFPA Style B (Class B) only.
 - Alarm Current: 11 mA
 - Short Circuit Current: 24 mA maximum
 - Maximum Detector Current in Standby: 1.8 mA
 - Maximum Loop Resistance: 30 ohms
 - Detector Loop Current is sufficient to ensure operation of a minimum of one alarmed detector per zone*
 - Standby Current: 5.17 mA (including End-of-Line Resistor)
- Channel/Input 2 and Channel/Input 4 - Style B (Class B) contact closure input:
 - Short Circuit Current: 4.46 mA maximum
 - Maximum Loop Resistance: 100 ohms
 - Standby Current: 2.66 mA
 - Refer to the *Device Compatibility Document* for listed compatible devices.

Notification Appliance Circuit - TB4 Terminals 1(+) & 2(-)

The 411UDAC Notification Appliance Circuit may only be used to supplement host panel NACs
 Style Y (Class B) power-limited and supervised circuit (monitored for opens, shorts, and earth fault)
 Maximum voltage drop in wiring: 2.0 VDC
 Operating voltage nominal 13.8 VDC
 Current for all external devices: 1.0 amp
 End-of-line resistor: 2.2K ohms, ½ watt (P/N 27070)
 Refer to the *Device Compatibility Document* for listed compatible devices

Two Form-C Relays - TB1 Terminals 1 through 6

Operating voltage nominal 12 VDC
 Contact rating: 2.0 amps @ 30 VDC (resistive) or 0.5 amps @ 30 VAC (resistive)
 Non-supervised

12 VDC Resettable Special Application Power - TB4 Terminals 3(+) and 4(-)

Operating voltage nominal 12 volts
 Maximum ripple voltage: 10 mV_{RMS}
 Up to 200 mA is available for powering 4-wire smoke detectors
 Power-limited and supervised with a UL-listed power supervision relay
 For power supply and battery calculations, refer to Section 6.

1.3 Circuits

The 411UDAC circuit board contains a MicroController Unit (MCU), dual modular phone line jacks, piezo sounder, and connectors for input, output and power wiring. A piezo silence switch and reset switch are provided on the membrane panel which plugs into connector J7 on the main circuit board.

1.3.1 Channels/Inputs

Four input channels are provided on the 411UDAC. The 411UDAC can be used to monitor a host FACP (Fire Alarm Control Panel) in Slave Mode or as a stand-alone FAC (Fire Alarm Communicator). Each input can be programmed to monitor the following conditions:

- fire alarm activation
- 4-wire smoke (channels 1 & 3 only)
- pull station
- normally open contact device
- waterflow
- trouble activation
- fire supervisory activation

1.3.2 Notification Appliance Circuit

One Style B NAC (Notification Appliance Circuit) requiring a 2.2K ohm End-of-Line resistor. This NAC can only be used to supplement host panel NACs.

1.3.3 Output Circuits

- Modular jacks are used to interface the primary and secondary phone lines to the public telephone network. Phone lines are fully supervised at all times (if communication is enabled).
- 12 volt resettable special application power output (200 mA)
- 12 volt battery charger will charge up to 14 AH batteries

1.3.4 Auxiliary Relays

Two dry Form-C relays (P/N: 411RK), with contacts rated for 2.0 amps @ 30 VDC (resistive) or 0.5 amps @ 30 VAC (resistive), are installed on the main circuit board. Each relay is programmable for:

- ✓ Alarm
- ✓ Fire supervisory - latching
- ✓ Fire supervisory - autoresettable
- ✓ Host panel trouble
- ✓ DACT trouble
- ✓ Total communications failure

1.3.5 Earth Ground

Connect a separate earth ground wire to ground stud in backbox for transient protection (refer to Figure 2.3 on page 21 for location of stud).

1.4 Controls and Indicators

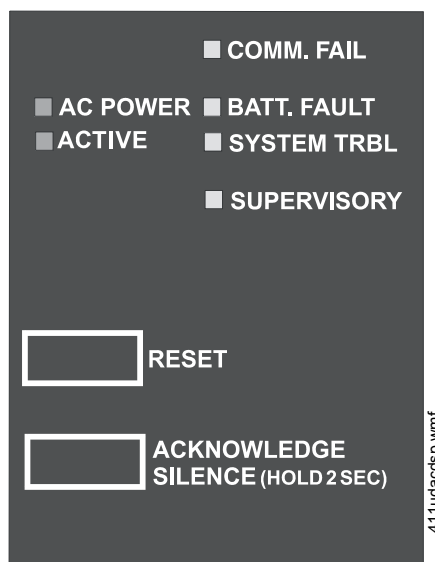

Figure 1.2 411UDAC Controls and Indicators

Front Panel Switch

- Reset Switch - to reset 411UDAC circuits
- Acknowledge/System Silence Switch
 - press once to acknowledge alarm or trouble (silence local 411UDAC piezo sounder and change all flashing LEDs to steady on)
 - press a second time and hold for minimum of two seconds to perform a System Signal Silence (silence Notification Appliance Circuit)

411UDAC Piezo Sounder

- The 411UDAC piezo sounder is used to locally annunciate DACT alarms and troubles. DACT troubles include input channel open circuit, NAC fault, phone line 1 or 2 voltage fault, phone number 1 or 2 communication fault and total communication failure. Separate and distinct sounds are provided for the following conditions:
 - ✓ alarm - steady On
 - ✓ trouble - 1 second On and 1 second Off
 - ✓ supervisory - ½ second On and ½ second Off

Front Panel Indicator

- AC Power - green LED
- Input Active - red LED
- Communication Fail - yellow LED
- System Trouble - yellow LED
- Supervisory - yellow LED
- Battery Trouble - yellow LED

Circuit Board Indicator

- Earth Fault - yellow LED (indicates zero impedance between panel and earth ground)

1.5 Components and Accessories

Main Circuit Board

The main circuit board contains the system's MCU (microcontroller unit), power supply, other primary components and wiring interface connectors. The main circuit board is shipped in the same carton as the cabinet but is not mounted in the cabinet. The circuit board should be installed only after the cabinet is mounted to the wall and the area is clean and free of potential contaminants.

Cabinet

The cabinet is red and measures 14.5" (36.83 cm) high X 12.875" (32.7 cm) wide X 4.5" (11.43 cm) deep. It provides space for up to two 7 Amp Hour batteries which must be ordered separately. A supplied bezel must be installed in the door opening.

Trim Ring

An optional Trim Ring (P/N TR-6-R) is available for the backbox. The Trim Ring provides a finished appearance for a semi-flush mounted panel.

Transformer Assembly

One transformer is shipped in the same carton as the cabinet and main circuit board but not mounted in the cabinet. The transformer should be installed before the cabinet is mounted to the wall.

Fire•Watch 411 Series DACT Programmer (Model PRO-411)

The PRO-411 is an optional DACT programmer which can be used to troubleshoot and program the 411UDAC, as well as access the various modes of operation. The PRO-411 must be ordered separately.

PK-411UD Upload/Download Software Kit

The optional PK-411UD Kit consists of the PK-411UD Upload/Download software on CD and the PK-411UD Program Manual. The PK-411UD enables a user to program the 411UDAC off site via the public switched telephone network using any personal computer with Windows[®] XP or greater and a 1200 baud Hayes[®] compatible modem.

1.6 Digital Communicator Operation

The 411UDAC has been designed to be compatible with a wide variety of fire alarm, nonfire and combination control panels (Slave Mode operation). Numerous formats are also available for communication to a central station. Two modular phone jacks allow easy connection to telephone lines. Modular jacks are labeled PH1 and PH2 for the Primary and Secondary phone lines. The digital communicator provides the following functions:

- Line Seizure- takes control phone lines, disconnecting any premise phones which may be using the same lines
- Off/On-Hook - perform on and off-hook status to phone lines
- Listen for dial tone - 440 hertz tone typical in most networks
- Dialing the Central Station(s) phone number - default is Touch-Tone[®], programmable to rotary
- Discern proper Central Station 'ACK' and 'Kiss-off' tone(s)
- Transmit data to the Central Station(s)
- Verify data has been accepted by the Central Station(s)
- Hang-up and release phone lines
- Communicate in a variety of formats (Table 4.1, "Format Selection Addresses (20 and 50) Programming," on page 55).

1.7 Panel Configuration

The 411UDAC can be configured, through programming, for the following modes of operation:

- Stand-alone Mode With Communicator Enabled - the 411UDAC functions as a latching digital alarm communicator in which all input circuit activations latch (except those programmed as autoresettable) and are restored only by pressing the local reset switch. The onboard communicator will attempt to transmit events to a Central Station
- Slave Mode With Communicator Enabled - the 411UDAC functions as a nonlatching slave to a host control panel and the onboard digital alarm communicator will attempt to transmit events to a Central Station
- Slave Mode With Communicator Disabled - the 411UDAC functions only as a nonlatching slave to a host control panel. The digital alarm communicator will not transmit to a Central Station

1.8 Operational Modes

1.8.1 Normal Mode

Normal Mode is the standard mode of operation in which the 411UDAC monitors the channel/input circuits as well as telephone line voltage and other internal circuits. In addition to locally annunciating system trouble, active channel/input and communication fail, the onboard communicator transmits system status information to UL listed central station receivers if programmed to do so. Transmitted data includes fire alarm, fire alarm trouble, supervisory alarm and AC loss information. Specific digital communicator troubles are also transmitted.

1.8.2 Real Time Clock Mode

Real Time Clock Mode allows the user to change the digital alarm communicator's internal 24 hour clock. Connecting an external Programmer allows access to the various Modes of operation. While the 411UDAC is in Real Time Clock Mode, it does not monitor channel inputs. Use of this mode requires a valid password.

1.8.3 Program Mode

Program Mode is used to change the programmed functions of the 411UDAC. While the 411UDAC is in Program Mode, it does not monitor channel inputs. In addition, some program items will be locked, which will prevent editing while the communicator is active (dialing, transmitting, etc.). Use of this mode requires a valid password.

1.8.4 Troubleshoot Mode

Troubleshoot Mode may be used to sample and display status for all channel/input circuits, Notification Appliance Circuit, AC power, battery, charger and 12 volt resettable power. In addition, Troubleshoot Mode may be used for testing the telephone line interconnect wiring. Connection from the 411UDAC's modular jacks, through the RJ31X jacks and into the telephone network may be easily checked. In this mode, the Programmer keypad acts similar to a telephone touchpad. While the 411UDAC is in Troubleshoot Mode, it does not monitor channel inputs.

1.8.5 Default Mode

Default Mode may be used to return all 411UDAC programming back to the factory default settings and to reset the Real-Time Clock to '00:01' midnight. See "Default Mode" on page 51.

1.9 Telephone Requirements and Warnings

1.9.1 Telephone Circuitry - PH1 & PH2

AC Ringer Equivalence Number (REN) = 0.4B

Mates with RJ31X Male Connector

Supervision Threshold: less than 5.0 volts for 2 minutes

The REN is used to determine the quantity of devices which may be connected to the telephone line. Excessive RENs on the telephone line may result in the devices not ringing in response to an incoming call. In most, but not all areas, the sum of the RENs should not exceed five (5.0). To be certain of the number of devices that may be connected to the line, as determined by the total RENs, contact the telephone company to determine the maximum REN for the calling area.

1.9.2 Digital Alarm Communicator:

Before connecting the 411UDAC to the public switched telephone network, the installation of two RJ31X jacks is necessary. The following information is provided if required by the local telephone company:

Manufacturer: Fire•Lite Alarms Inc./Notifier
One Fire-Lite Place
Northford, CT 06472

Product Model Number: 411UDAC

FCC Registration Number: 1W6AL04B411UDAC

AC Ringer Equivalence: 0.4B

FCC ID label is located on the inside cover.

Important! *The DACT must not be used to dial a phone number that is call-forwarded per requirements of UL 864 9th Edition.*

1.9.3 Telephone Company Rights and Warnings

The telephone company, under certain circumstances, may temporarily discontinue services and/or make changes in its facilities, services, equipment or procedures which may affect the operation of this digital communicator. However, the telephone company is required to give advance notice of such changes or interruptions. If the digital communicator causes harm to the telephone network, the telephone company reserves the right to temporarily discontinue service. Advance notification will be provided except in cases when advance notice is not practical. In such cases, notification will be provided as soon as possible. The opportunity will be given to correct any problems and to file a complaint.

DO NOT CONNECT THIS PRODUCT TO COIN TELEPHONE, GROUND START OR PARTY LINE SERVICES.

When the digital communicator activates, premise phones will be disconnected.

Two separate phone lines are required. Do not connect both telephone interfaces to the same telephone line.

The digital communicator must be connected to the public switched telephone network upstream of any private telephone system at the protected premises.

An FCC compliant telephone cord must be used with this equipment. This equipment is designed to be connected to the telephone network or premises wiring using a compatible RJ31X male modular plug which is Part 68 compliant.

Section 2: Installation

2.1 Mounting Options

The cabinet may be either semi-flush or surface mounted. The door is removable during the installation period by opening and lifting it off the hinges. The cabinet mounts using two key slots and two additional 0.25" diameter holes located in the backbox. The keyslots are located at the top of the backbox and the two securing holes at the bottom.

Carefully unpack the system and check for shipping damage. Mount the cabinet in a clean, dry, vibration-free area where extreme temperatures are not encountered. The area should be readily accessible with sufficient room to easily install and maintain the panel. Locate the top of the cabinet approximately five feet above the floor with the hinge mounting on the left. Determine the number of conductors required for the devices to be installed. Sufficient knockouts are provided for wiring convenience. Select the appropriate knockout(s) and pull the required conductors into the box. All wiring should be in accordance with the National and/or Local codes for fire alarm systems.

2.2 Mounting

Backbox Mounting

1. Mark and predrill holes for the top two keyhole mounting bolts using the dimensions shown in Figure 2.1.
2. Install two upper fasteners in the wall with the screw heads protruding.
3. Using the upper 'keyholes', temporarily mount the backbox over the two screws.
4. Mark the lower two holes, remove the backbox from the wall and drill the lower two holes in the wall.
5. Before mounting the backbox to the wall, install the supplied transformer in the backbox. Position the holes in the transformer flanges over the transformer mounting studs. Refer to Figure 2.1.
6. Secure the transformer with the supplied nuts and attached washers.

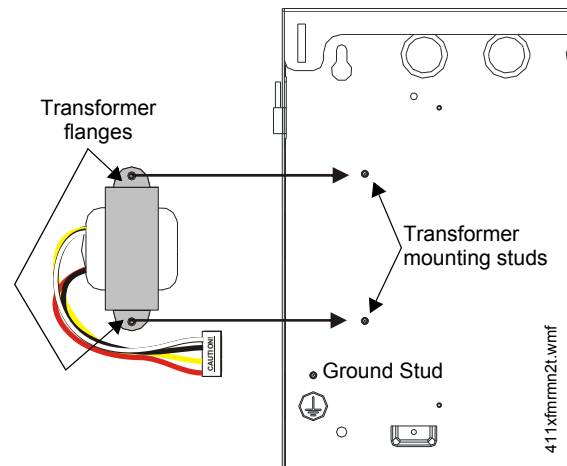

Figure 2.1 Transformer Mounting

7. Mount the backbox to the keyhole mounting bolts, install and tighten the remaining fastener.

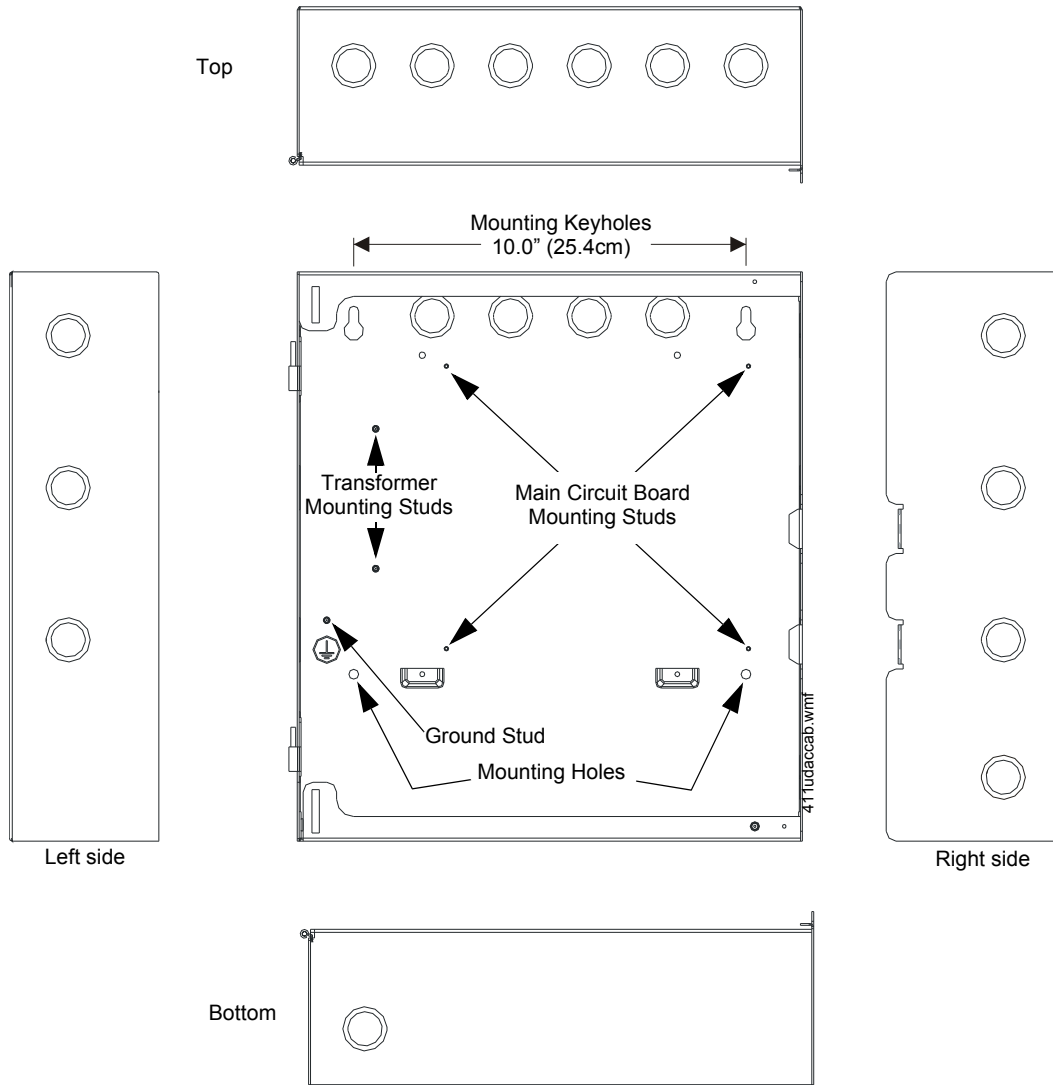

Figure 2.1 Cabinet Dimensions and Knockout Locations

Main Circuit Board Mounting

1. When the location is clean and free of construction dust or other contaminants, install the main PC board by installing the four supplied standoffs on the four main circuit board mounting studs located in the backbox. Refer to Figure 2.1 for locations.
2. Position the main circuit board's four corner mounting holes over the four standoffs just installed. *Be certain to observe the proper ESD (Electro Static Discharge) precautions to prevent damage to the static sensitive circuits. This includes, but is not limited to, use of a wrist strap.*
3. Secure the main circuit board to the standoffs with the four supplied screws and attached washers.
4. Plug the transformer connector into the main circuit board connector J4. The connector is keyed and can only be plugged-in one way. Refer to Figure 2.3 on page 21 and Figure 2.11 on page 29 for transformer connector location and AC power connections.

5. When wiring is completed, re-install the door.

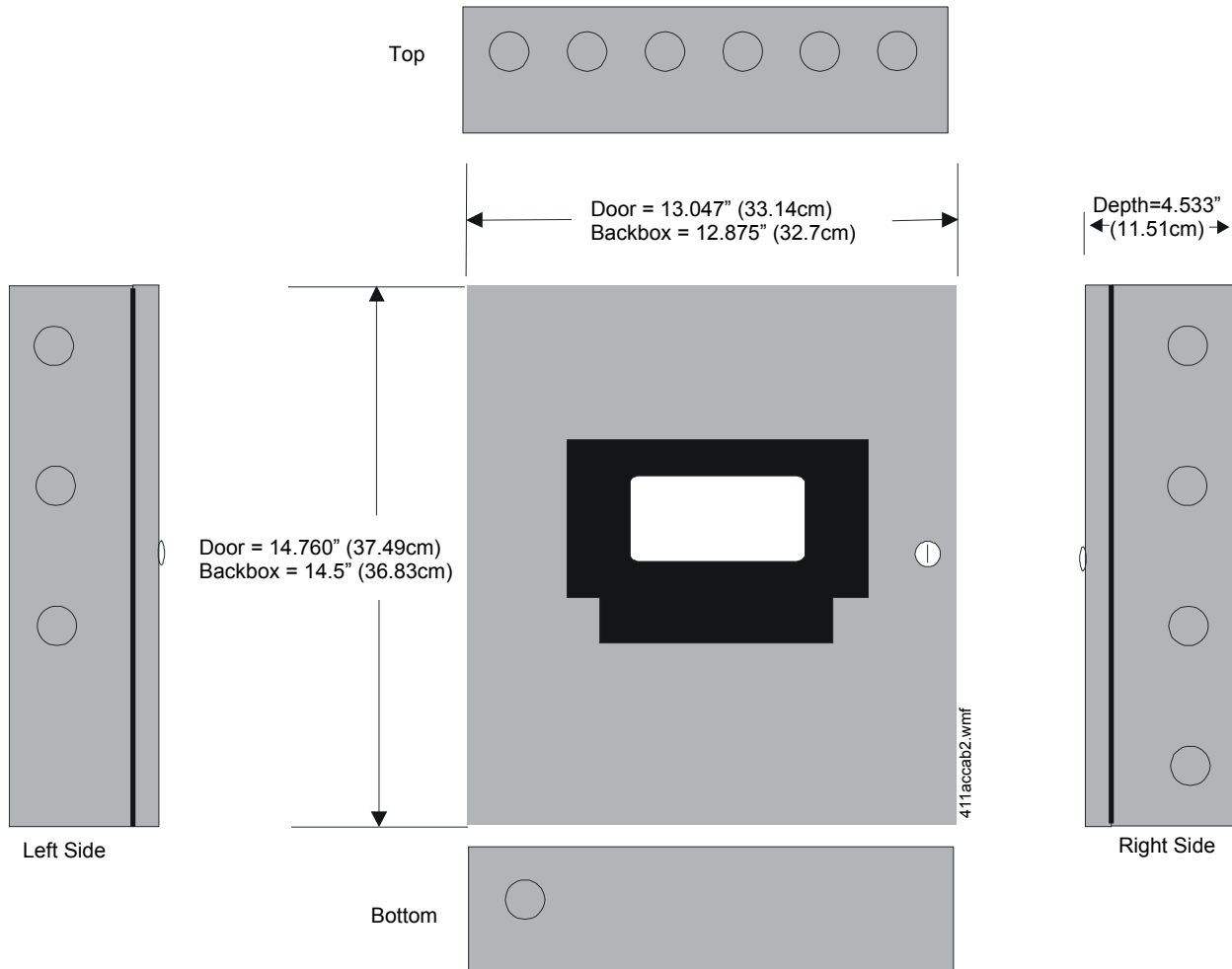

Figure 2.2 411UDAC Backbox

2.3 Operating Power



CAUTION: DISCONNECT POWER BEFORE SERVICING

SEVERAL DIFFERENT SOURCES OF POWER CAN BE CONNECTED TO THE 411UDAC. DISCONNECT ALL SOURCES OF POWER BEFORE SERVICING THIS UNIT. THE COMMUNICATOR AND ASSOCIATED EQUIPMENT MAY BE DAMAGED BY REMOVING AND/OR INSERTING MODULES OR CABLES WITH POWER APPLIED.

Primary Power Source (AC) and Earth Ground Connections

AC power connections are made inside the 411UDAC cabinet. The primary power source is 120 VAC, 60 Hz, 0.7 amps. Run a pair of wires (with ground conductor) from the protected premises main breaker box to TB3 of the main circuit board. As per the National Electric Code, use 14 AWG (2.00 mm²) or heavier gauge wire with 600V insulation. No other equipment may be connected to this circuit. In addition, this circuit must be provided with overcurrent protection and may not contain any power disconnect devices.

A separate earth ground connection must be made to ensure proper panel operation and lightning and transient protection. Remove the two keys nuts from the grounding stud in the backbox. Connect the incoming earth ground wire to supplied cable #71073 with a wire nut. Position the ring terminal end over the grounding stud. Secure with one of the keys nuts. Place the ring terminal from the other supplied ground cable #71073 over the ground stud and secure with the second keys nut. Wire the ground cable to the bottom position of TB3. Refer to the figure below for location of the stud. Apply AC power to the panel only after the system is completely installed and visually checked. Note that AC power must be applied to the panel before installing the battery interconnect cable.

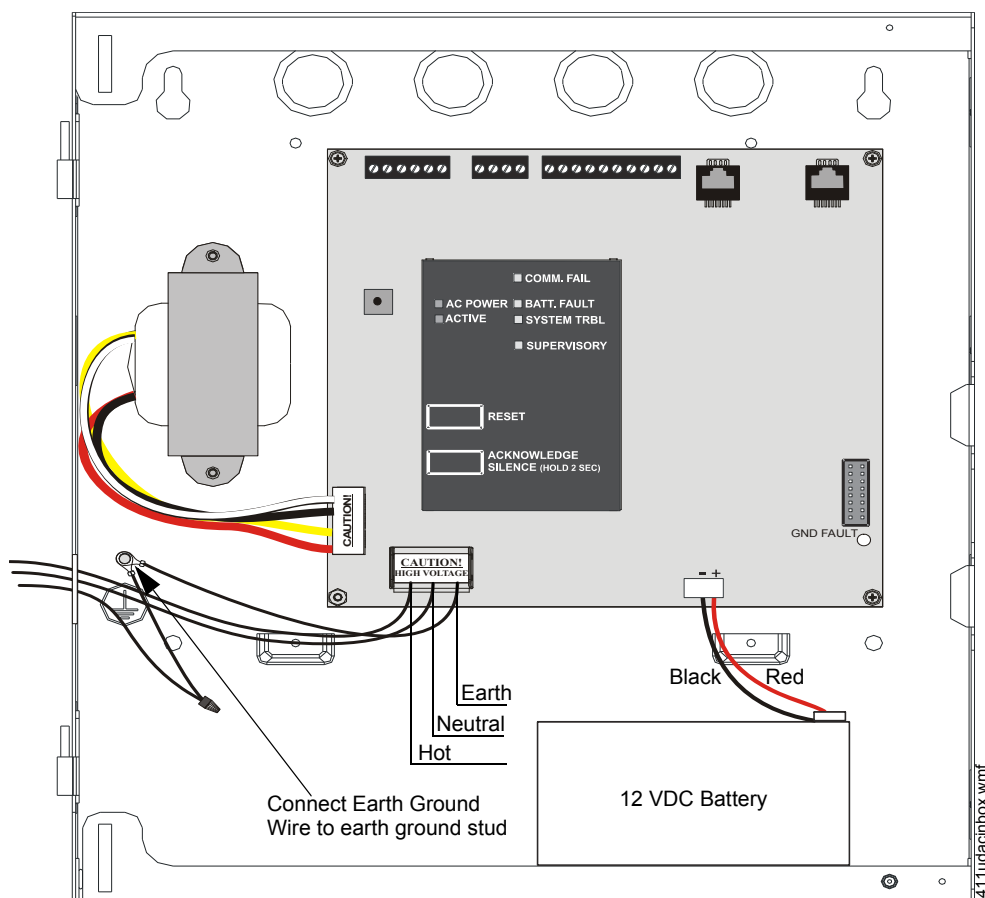

Figure 2.3 Operating Power Connections

Secondary Power Source (batteries)

Observe polarity while connecting the battery. When installing one 12 volt battery for up to 12 Amp Hour applications, connect the supplied battery cable (P/N 75516) by sliding the connector attached to the long red wire onto the positive (+) battery terminal and the connector attached to the long black wire onto the negative (-) battery terminal. Tie-wrap or tape the two unused short wires to the long wires.

When installing two 12 volt, 7 Amp Hour batteries (in parallel) for up to 14 Amp Hour applications, follow the same procedure as described for one battery except connect the unused short wires to the second battery. Slide the connector attached to the short red wire onto the positive (+) terminal of the second battery and the connector attached to the short black wire onto the negative (-) battery terminal of the second battery.

When the panel is ready to have power applied, connect the battery cable plug to connector J3 on the 411UDAC main circuit board. The battery charger is capable of recharging sealed lead acid type batteries. Refer to the battery calculations table to determine the correct battery rating.



CAUTION: BATTERY CONTAINS SULFURIC ACID

THE BATTERY CONTAINS SULFURIC ACID WHICH CAN CAUSE SEVERE BURNS TO THE SKIN AND EYES, AND CAN DESTROY FABRICS. IF CONTACT IS MADE WITH SULFURIC ACID, IMMEDIATELY FLUSH THE SKIN OR EYES WITH WATER FOR 15 MINUTES AND SEEK IMMEDIATE MEDICAL ATTENTION.

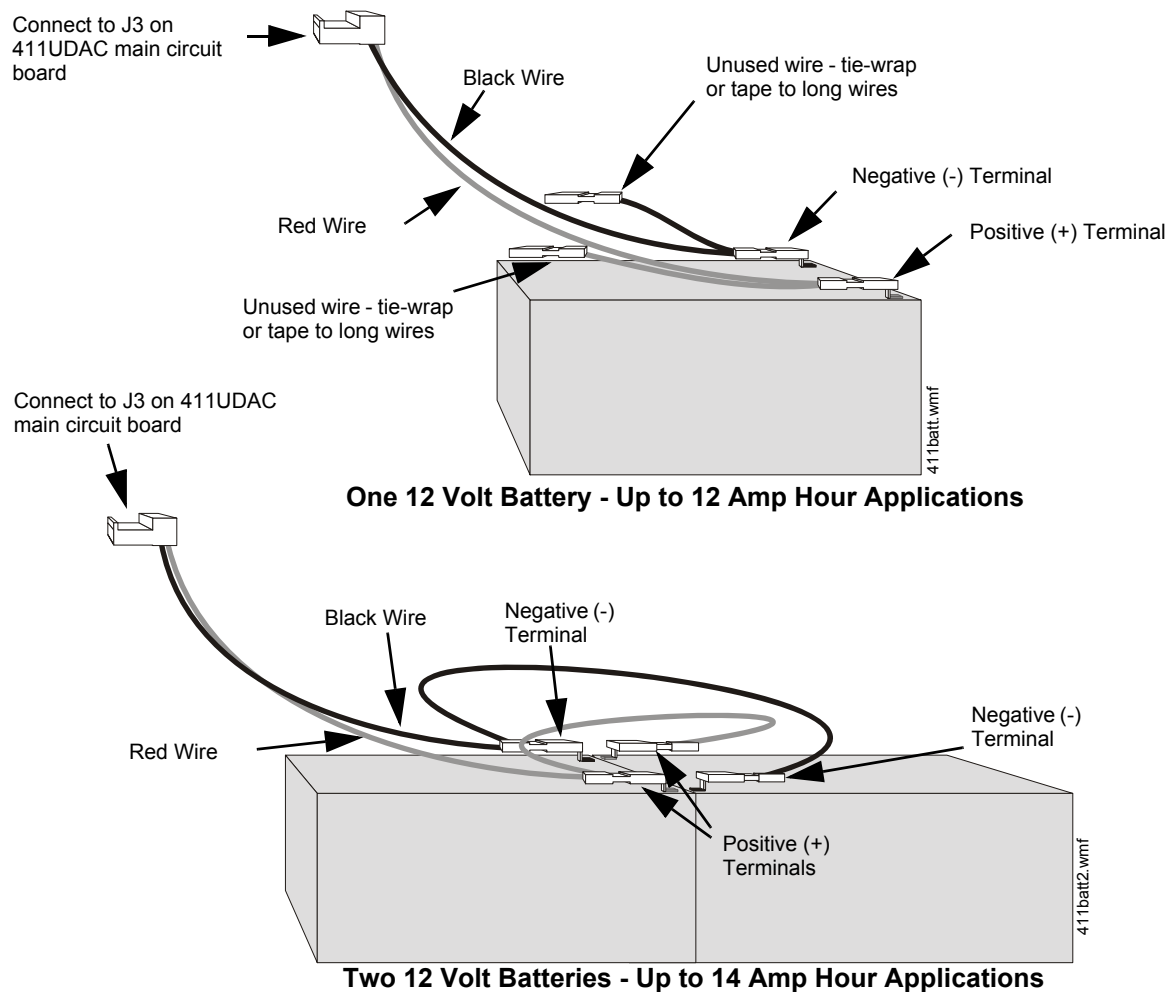

Figure 2.4 Battery Cable Connections

2.4 Input Channels

The 411UDAC has four channel inputs. Channel/input field wiring is supervised for opens (trouble), shorts (alarm) and ground faults (zero ohms impedance between panel and earth ground) by the 411UDAC. All conditions are visually and audibly annunciated and, if programmed, communicated to a Central Station.

Each channel is a Style B (Class B) Initiating Device Circuit with the exception of channel/input 3 which can be configured for Style B or Style D (Class A). All inputs can be connected to normally-open contact type devices. In addition, inputs 1 and 3 can be connected to conventional 4-wire smoke detectors. Figure 2.5, "Wiring Initiating Device Circuits" on page 23 for information on wiring Style B and Style D circuits.

The channel/inputs may be programmed as shown below:

- 4-wire smoke detector (inputs 1 & 3 only)
- Pull station
- Normally-open contact device
- Host panel trouble
- Supervisory
- Supervisory autoresettable
- Waterflow silenceable
- Waterflow nonsilenceable

A maximum of five waterflow devices may be used on any circuit programmed as a waterflow zone per NFPA 72.

It is allowable to mix an assortment of device types (i.e. smoke detectors, heat detectors, pull stations, etc.) on any zone. This is not recommended, however, since specific and detailed reports will not be possible (particularly critical when using Contact ID format). For example, the report of general fire alarm versus pull station fire alarm or smoke detector fire alarm could not be distinguished.

The factory default programming for each channel is as follows:

- ✓ Channel 1 - fire alarm (4-wire smoke)
- ✓ Channel 2 - pull station
- ✓ Channel 3 - fire alarm (4-wire smoke)
- ✓ Channel 4 - pull station

The following illustration shows Channel 1 connected to 4-wire smoke detectors, and UL-listed power supervision relay; Channel 2 connected to manual pull stations; Channel 3 connected to manual pull stations; and Channel 4 connected to waterflow devices. In this example, the factory default programming for Channel 4 must be changed from *pull station* to *waterflow device*.

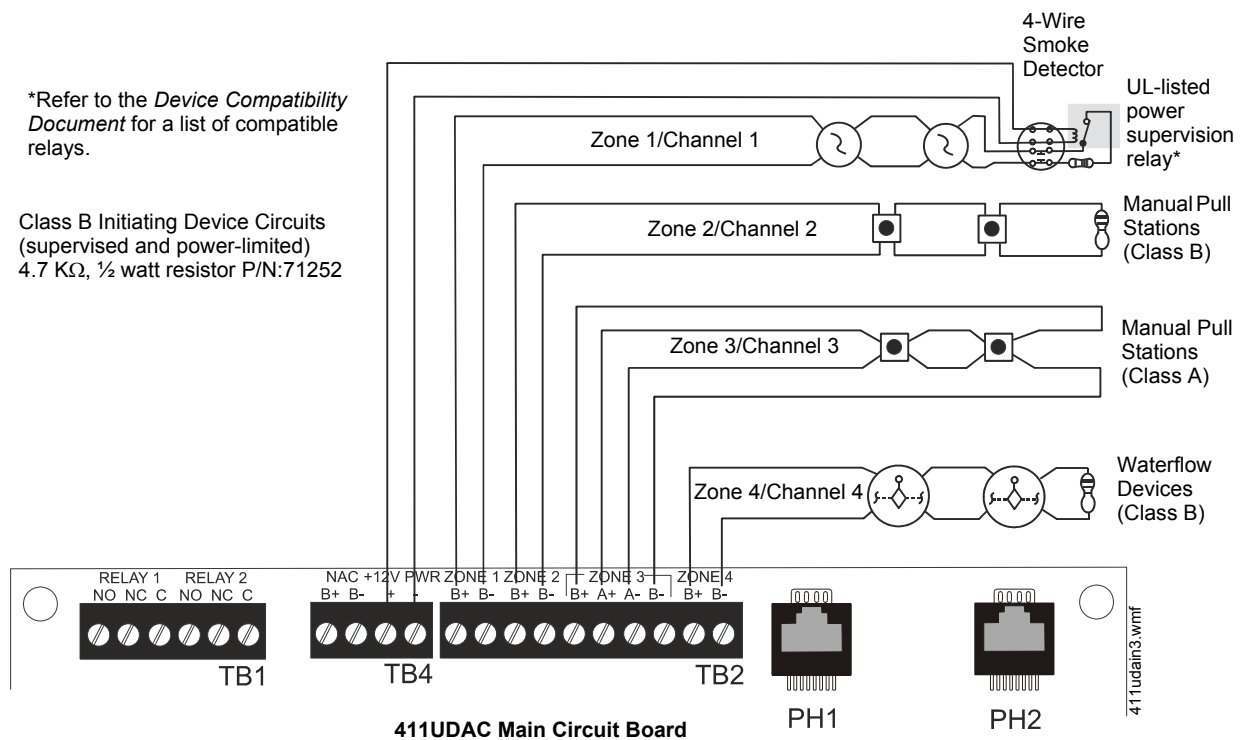

Figure 2.5 Wiring Initiating Device Circuits

Note: The addressable monitor module input, which is being used to monitor the 411UDAC Relay Output programmed for DACT Trouble must be programmed as 'DACT Trouble' at the FACP. The 411UDAC must be programmed as a Slave Communicator (programming address 64 set to '2')

Program the 411UDAC as follows:
 Channel 1 - Normally Open Contact Device (alarm)
 Channel 2 - Host Panel Trouble
 Channel 3 - Supervisory

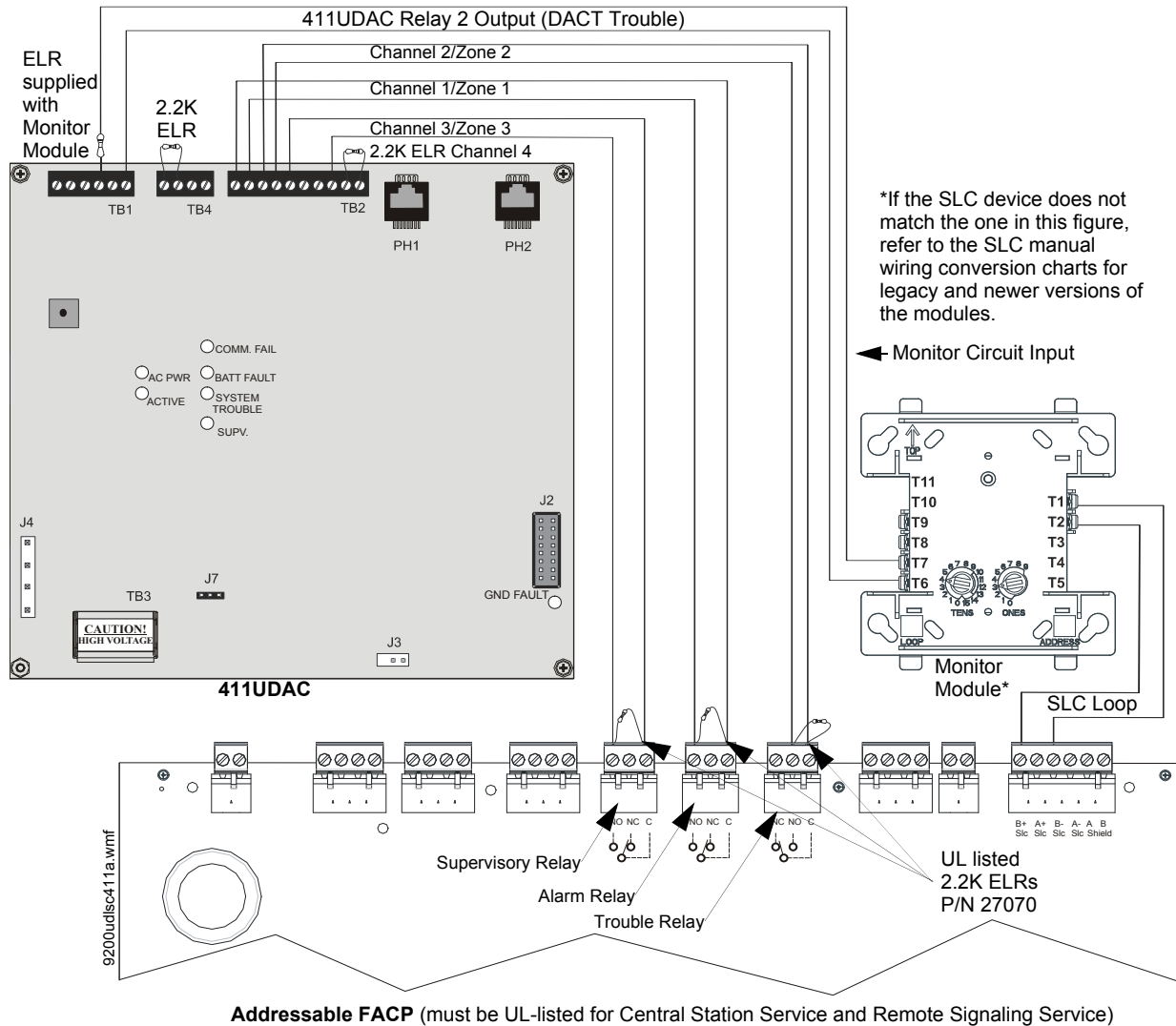

Figure 2.6 Typical Addressable FACP Connection to 411UDAC

2.5 Output Circuits

Notification Appliance Circuit

The 411UDAC provides one Style Y (Class B) NAC (Notification Appliance Circuit). The NAC is supervised and power-limited and is capable of 1.0 amp of current. Refer to the *Device Compatibility Document* for a listing of compatible notification appliances.

Notes:

1. The 411UDAC can only be used to supplement host panel NACs.
2. Do not connect strobes to the 411UDAC Notification Appliance Circuit.

The NAC may be programmed as follows:

- Silenceable
- Nonsilenceable (waterflow)
- Silence Inhibited (one minute)
- Autosilence (5 to 30 minutes)

Style Y (Class B) Notification Appliance Circuit
(supervised and power-limited).
2.2K ohms, ½ watt P/N 27070

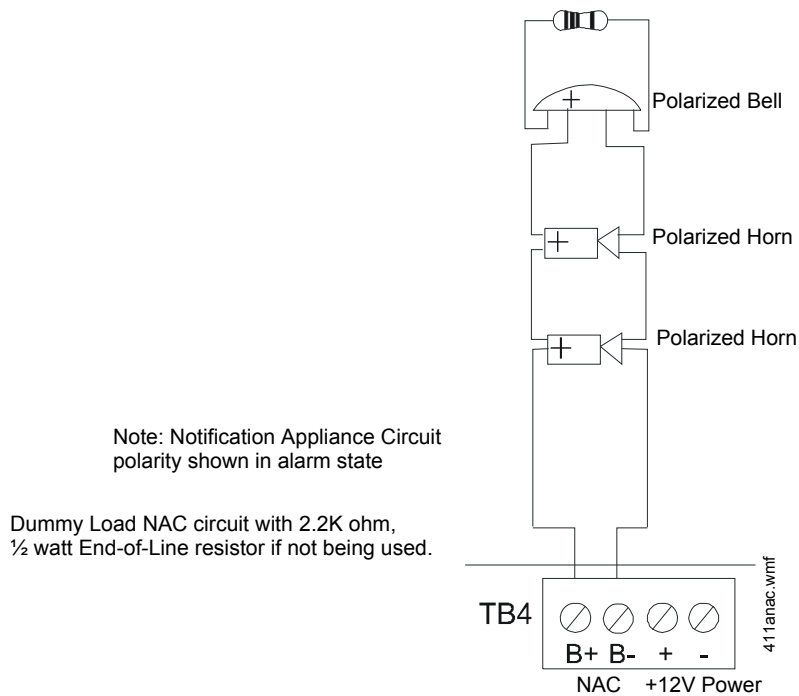

Figure 2.7 Notification Appliance Circuit Connections

Relay Programming

The relays are programmable for activation on fire alarm, host panel trouble, fire supervisory, total communication failure and DACT. Refer to “DACT Programming” on page 36. Addresses ‘85 - 88’ are used for programming relay functions and enable.

Note: Relay connections may be power-limited or nonpower-limited. However, connecting one type next to the other type is not allowed. Both circuits must be either power-limited or nonpower-limited.

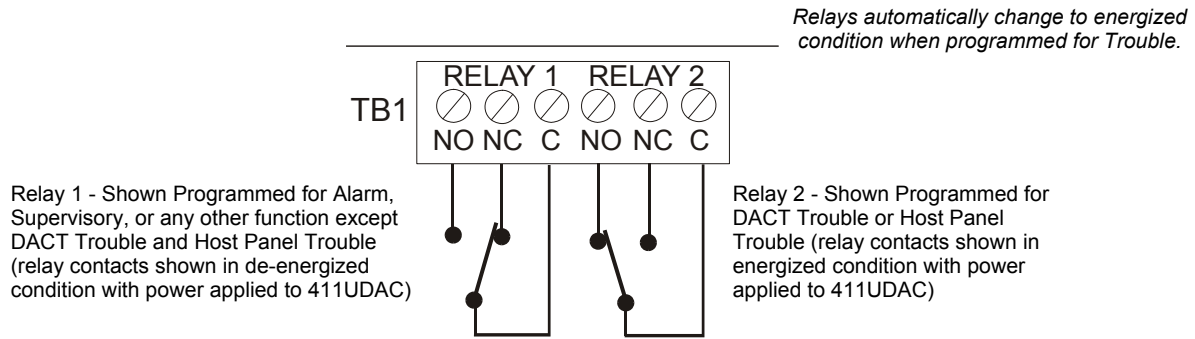

Figure 2.8 Programmable Relay

2.6 Telephone Circuits

Provision to connect two independent telephone lines is available via two telephone jacks labeled PH1 (Primary) and PH2 (Secondary). Telephone line control/command is possible via double line seizure as well as usage of an RJ31X style interconnection. (RJ31X jacks must be ordered separately).



CAUTION: PROPER FUNCTIONALITY

IT IS CRITICAL THAT THE 411UDAC BE LOCATED AS THE FIRST DEVICE ON THE INCOMING TELEPHONE CIRCUIT TO PROPERLY FUNCTION.

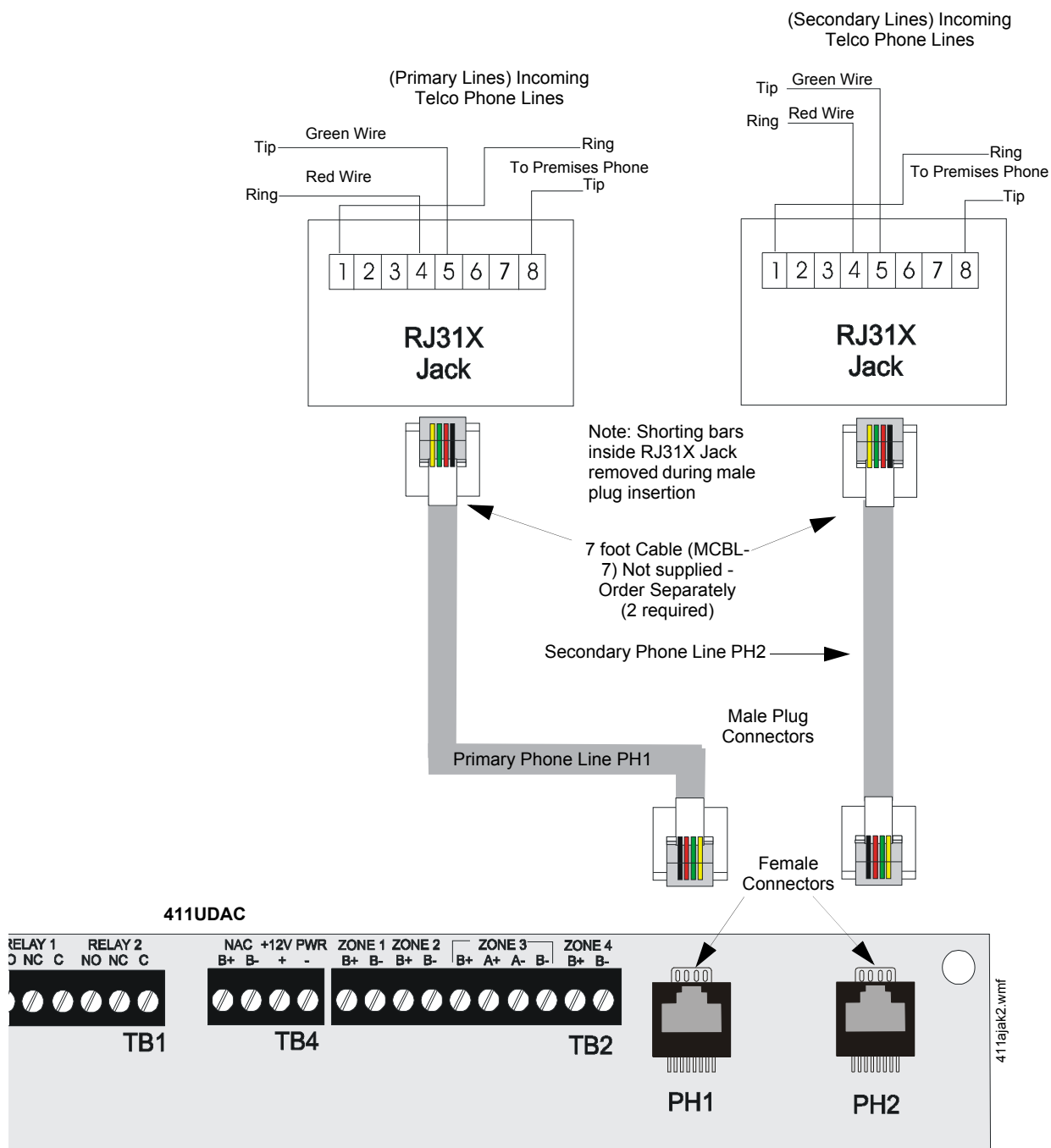

Figure 2.9 Wiring Phone Jacks

2.7 Optional Programmer

The Fire-Watch 411 Series DACT Programmer (Model PRO-411) is used to:

- ✓ switch between the digital alarm communicator's five Modes of operation
- ✓ set the digital alarm communicator's 24 hour internal clock in Real-Time Clock Mode
- ✓ program the 411UDAC digital alarm communicator in Program Mode
- ✓ test the status of input and output circuits (including telephone lines) in Troubleshoot Mode
- ✓ return all digital alarm communicator programming to the factory default settings in Default Mode

To use the PRO-411 Programmer:

1. Remove all power from the 411UDAC.
2. Unlock and open the 411UDAC door.
3. Connect the Programmer cable to connector J2 located in the lower right corner of the 411UDAC. Note that the key on the connector must align with the slot in the J2 connector.
4. Reapply power to the 411UDAC.
5. Operate the Programmer by pressing the **MODE** key. Enter the appropriate four digit code and then press the **[ENTER/STORE]** key.

Note that it is not possible to switch from Normal Mode to any other mode if any of the four Channels is programmed for fire alarm or fire supervisory and is active, that is, in alarm (shorted).

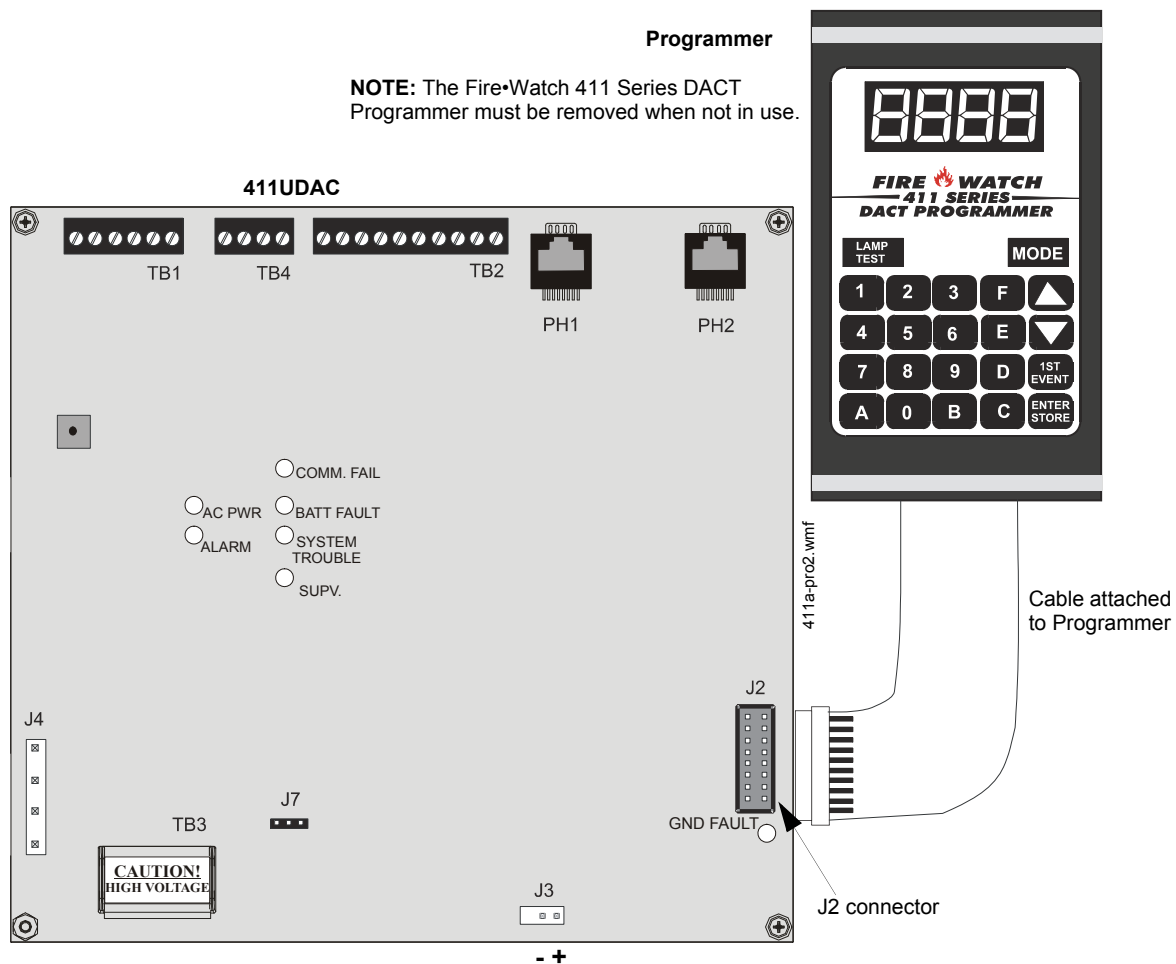

Figure 2.10 Programmer Connection to 411UDAC

2.8 UL Power-limited Wiring Requirements

Power-limited and nonpower-limited circuit wiring must remain separated in the cabinet. All power-limited circuit wiring must remain at least 0.25" away from any nonpower-limited circuit wiring. Furthermore, all power-limited and nonpower-limited circuit wiring must enter and exit the cabinet through different knockouts and/or conduits. A typical wiring diagram for the 411UDAC is shown below.

Note: Relay connections may be power-limited or nonpower-limited, provided that 0.25" spacing is maintained between conductors of power-limited and nonpower-limited circuits.

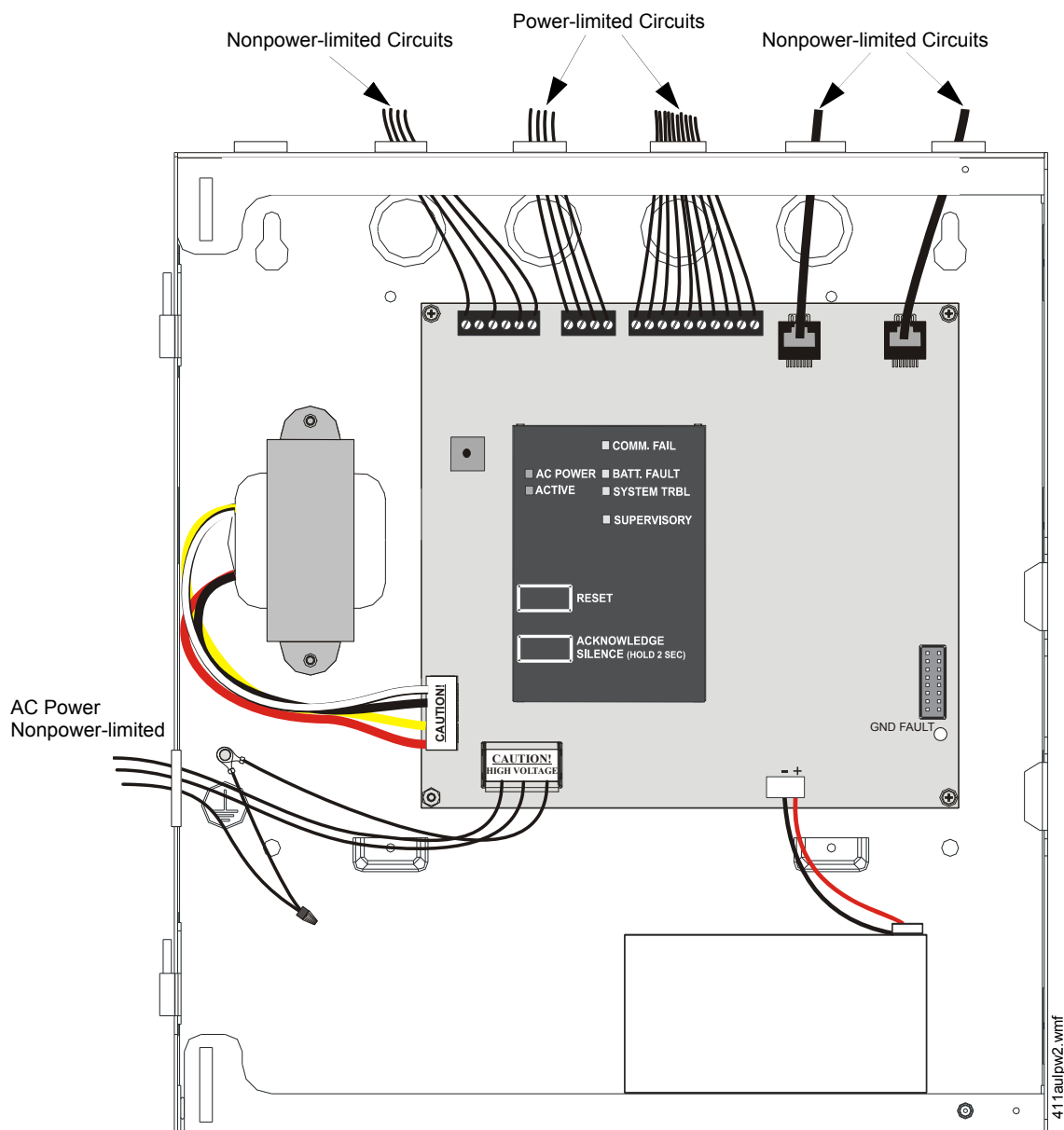

Figure 2.11 Typical UL Power-limited Wiring Diagram

Section 3: Modes of Operation

The 411UDAC has five operational modes:

- Normal Mode
- Real Time Clock Mode
- Program Mode (requires password)
- Troubleshoot Mode
- Default Mode (requires password)

The operational mode for the 411UDAC is Normal Mode. The operator is able to switch between any modes of operation provided no alarm events are active in the system. It should be noted that the unit will not respond to input activations while in any mode except Normal Mode.

Some modes require a password. Refer to Section 3.2.

Access to any other Mode requires connection of the PRO-411 DACT Programmer which consists of a keypad and display. Figure 3.1, “Programmer Keypad” on page 31.

Note that if the 411UDAC is configured to operate as a Slave Communicator, it will attempt to transmit all panel status to a Central Station. If set to operate in the Test Communicator configuration, the 411UDAC will function as a local slave panel only without transmitting panel status to a Central Station.

3.1 Normal Mode

Normal Mode is the standard (default) mode of operation for the 411UDAC. The unit continuously monitors the status of the four input channels as well as the status of the onboard digital communicator. If no activity is detected on the four input channels (no shorts or opens) and the 411UDAC is operating free of internal troubles, the unit will display the following conditions:

- ✓ All LEDs are off except the AC Power LED
- ✓ NAC output is off
- ✓ Onboard piezo sounder is off
- ✓ The relays are in their normal deactivated state
- ✓ Communicator is not transmitting to the Central Station

The 411UDAC transmits system status reports to a central station, if programmed to do so, via the public switched telephone network. Two supervised telephone line connections are made to interface the digital communicator to the telephone lines. Both telephone lines are supervised by the 411UDAC for proper voltage.

The 411UDAC is capable of line seizure on both the primary and secondary telephone line interfaces. *Any time the digital communicator detects the necessity to call the Central Station, line seizure will disconnect any local premises phones sharing the same telephone line. Sharing of phone lines, for fire systems, must be approved by the Local Authority Having Jurisdiction.* All transmissions to the Central Station will be sent over the Primary phone line. In the event of a noisy or faulty phone line, transmissions will be sent over the backup Secondary phone line.

Transmission options exist to:

- send reports to the secondary phone number as backup only
- send reports to both the primary and secondary phone numbers
- send reports to the first available central station phone number

If 10 total attempts to communicate are unsuccessful, the 411UDAC will turn on the Communication Fail LED.

The 411UDAC meets NFPA 72 requirements for Remote Station Protective Signaling Service and Central Station Signaling Service reporting requirements for: (a) the type of signal, (b) condition and (c) location of the reporting premises. See “Central Station Communications” on page 54, for additional information.

The 411UDAC can be switched from Normal Mode to any other Mode, provided no channel programmed for fire alarm or fire supervisory is active, that is, in alarm (shorted). The PRO-411 DACT Programmer, for use with the Fire•Watch 411 Series, must be connected to the 411UDAC in order to change from mode to mode.

3.1.1 Programmer Key Functions

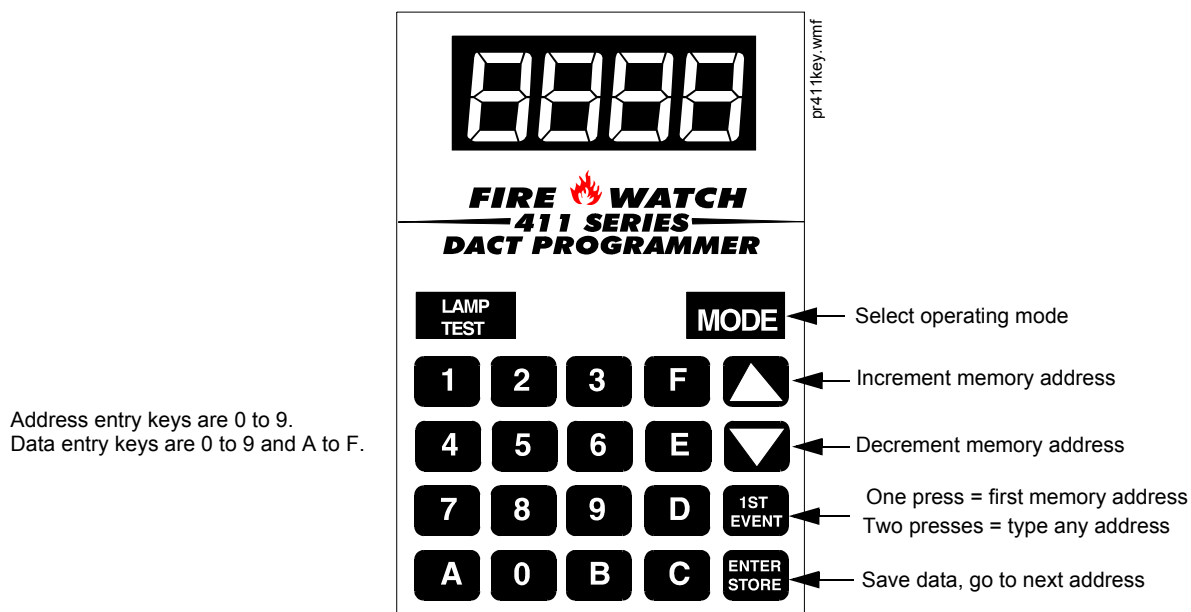

Figure 3.1 Programmer Keypad

MODE KEY

Pressing the **MODE** key followed by a valid 4-digit numerical code and the **[ENTER/STORE]** key selects one of the five modes of operation. To enter Normal Mode from any other mode, press the **MODE** key followed by **6676** and then **[ENTER/STORE]**.

- **6676** spells NORM on a Touch-Tone® phone.

If an incorrect key is entered, reenter the proper 4-digit code before pressing the **[ENTER/STORE]** key. Note that as information is entered into the 411UDAC, the digits will scroll across the Programmer display from right to left.

```

    _6
   _66
  _667
 6676
    
```

A pause of up to 10 seconds between each number is allowed while entering the code.

LAMP TEST KEY

Pressing the Lamp Test key on the Programmer, while the digital communicator is in Normal Mode, will cause the front panel LEDs and all segments of the four 7-segment display on the 411UDAC to light. A Lamp Test can only be performed in Normal Mode. The Lamp Test key can also be used in Troubleshoot Mode to view the 12 volt resettable power value.

1st EVENT KEY

This key, along with the **UP** and **DOWN** arrow keys, are used only in Program Mode. Press the **1st EVENT** key at any time to display the first program memory address and its content. The following may be displayed on the Programmer:

00_F
(address) (data)

If the **1st EVENT** key is pressed a second time, the following will be displayed on the Programmer display:

0.
↑
Digit to be programmed

The contents of any address can be viewed by entering the digits of the desired address. For example, to view the contents of address 86, press the '8' key on the keypad. '8' will appear as the first digit in the display, a blank will appear in the position of the second digit and the decimal point will move one position to the right, indicating that the next digit can now be entered.

8.
↑
Digit to be programmed

Press the '6' key on the keypad. '6' will appear as the second digit on the display and the decimal point will move one position to the right. Press the **[ENTER/STORE]** to view the contents of address 86.

86_.

DOWN ARROW

Use the **DOWN** arrow key to decrement the memory address and view its content.

UP ARROW

Use the **UP** arrow key to increment the memory address and view its content.

ENTER/STORE

Stores entry into nonvolatile E² memory located on the 411UDAC printed circuit board, then increments to the next higher address.

3.1.2 Programmer Display

Four 7-segment red LED characters provide visual display of information in the various modes of operation.

3.2 Password Creation and Entry

In order to access the Default Mode or Programming Mode, a valid password must be entered.

1. Press the **MODE** key followed by the 4-digit entry code (**3337** for Default Mode or **7764** for Program Mode).
2. Press the **[ENTER/STORE]** key. The display will read **LinP** indicating that a valid password is required to continue.

3. For the initial power-up of the 411UDAC or for the first power-up after a manually defaulted password, key in the default password **0000** and press **[ENTER/STORE]**. The display will then read **dC_P**.
4. Press **d** to continue with the default password or press **C** to change to a new password.
5. If **d** is entered in step 4, the display goes directly to the programming/default modes.
6. If **C** is entered in step 4, the display will read **En_P** prompting for a new password.
 - Key in a new 4-digit password. Valid passwords are any four digit code from 0001-9999.
 - The display will then read **rEnP**. Key in the new password again for verification.
 - Once the new password has been verified, the programming/default modes will be accessed.

If at any time a password was entered incorrectly, the display will read **AErr** indicating an invalid entry was made.

3.3 Real Time Clock Mode

Real Time Clock Mode is entered by pressing the **MODE** key followed by the 4-digit entry code **2525** and pressing the **[ENTER/STORE]** key. Accessing this mode requires authentication. Refer to Section 3.2.

- **2525** spells CLCK on a Touch-Tone[®] phone.

If an incorrect key is entered, reenter the proper 4-digit code before pressing the **[ENTER/STORE]** key. Note that as information is entered into the 411UDAC, the digits will scroll across the Programmer display from right to left.

```

  _ 2
  _25
  _252
  2525

```

A pause of up to 10 seconds between each number is allowed while entering the code. After pressing the **[ENTER/STORE]** key, the 411UDAC will be in Real Time Clock Mode. A maximum of 10 minutes idle time is allowed at this point before beginning program entries and between each key stroke, otherwise, the 411UDAC will return to Normal Mode. Note that the time is not stored until the fourth and final digit is selected and the **[ENTER/STORE]** key is pressed. If the 411UDAC returns to Normal Mode prior to entering the fourth digit, no changes will be stored and the original time is retained.

On entering Real Time Clock Mode, **0.001** will appear on the Programmer display:

```

      0.001
      ↑
Digit to be programmed

```

The time is displayed in military time. Note the position of the decimal point in the display. This indicates that the first digit to be programmed is the one to the left of the decimal point. To program the first hour digit, press the corresponding number on the Programmer keypad and then press the **[ENTER/STORE]** key. For example, to program 2:00 PM (**1400** in military time), press '1' on the keypad and then the **[ENTER/STORE]** key. The number '1' will appear as the far left digit and the decimal point will move one position to the right indicating that the second digit from the left is now ready for programming.

```

      10.01
      ↑
Digit to be programmed

```

Enter the second hour digit (4 in this example) and press the [ENTER/STORE] key. The number '4' will appear as the digit second from the left and the decimal point will move one position to the right indicating that the third digit from the left is now ready for programming.

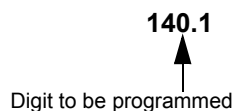

Enter the first minute digit (0 in this example) and press the [ENTER/STORE] key. The number '0' will appear as the digit third from the left and the decimal point will move one position to the right indicating that the fourth digit from the left is now ready for programming.



Enter the second minute digit (0 in this example) and press the [ENTER/STORE] key. The number '0' will appear as the digit fourth from the left. Following the entry of the fourth and final digit, the operating mode will immediately switch to Normal Mode, indicating that programming of the time is now completed.

To exit Real Time Clock Mode before completing clock programming, press the **MODE** key, followed by the 4-digit code for an alternate mode and then the [ENTER/STORE] key. During Real Time Clock Mode, if no key is pressed within 10 minutes, the 411UDAC will revert to Normal Mode.

Note that upon power-up, the internal clock starts running at 00:01 midnight. It must be changed so that the 411UDAC can accurately call in test signals to the Central Station. Upon power loss or on entering Default Mode, the clock reverts to 00:01 midnight and must be reset.

3.4 Program Mode

NOTICE TO USERS, INSTALLERS, AUTHORITIES HAVING JURISDICTION AND OTHER INVOLVED PARTIES			
This product incorporates field-programmable software. In order for the product to comply with the requirements in the Standard for Control Units and Accessories for Fire Alarm Systems, UL 864, certain programming features or options must be limited to specific values or not used at all as indicated below:			
Program feature or option	Permitted in UL 864? (Y/N)	Possible settings	Settings permitted in UL 864
AC Loss Delay	Y	AC Loss Delay = 0, 1, 2 (factory default), 6, 7, 8, 10, 11, 12, 13, 14, 15, 16, 17, or 18 hours Refer to "AC Loss Reporting Delay (60)" on page 45.	AC Loss Delay = 1 or 2 hours
Input Channel 1-4 Delay Timer	Y	0 – 179 seconds Refer to "Input Channel 1 Delay Timer (69 - 71)" on page 46	Delay timer = 0 - 90 seconds
Trouble Call Limit	N	Program Address 96 = 0 (factory default): unlimited calling to Central Station for any trouble condition Program Address 96 = 1: limits call for each unique trouble to 10 within a 24 hour period Refer to "Trouble Call Limit - Dialer Runaway Prevention (96)" on page 50	Program Address 96 = 0 for unlimited Central Station trouble calls

All programming selections made during Program Mode are stored in nonvolatile memory. This ensures that the 411UDAC will retain all entries made in Programming Mode even if power is removed.

The user must program the primary and secondary phone numbers, account numbers, 24-hour test report times and verify event codes for each Central Station account. The 411UDAC is shipped with the program options/features already factory programmed. Alternative options/features may be programmed if desired. If all factory default settings are acceptable, programming is complete.

Program Mode is entered by pressing the **MODE** key followed by the 4-digit program mode entry code **7764** and pressing the **[ENTER/STORE]** key. Accessing this mode requires authentication. Refer to Section 3.2.

- **7764** spells PROG on a Touch-Tone[®] phone.

If an incorrect key is entered, reenter the proper 4-digit code before pressing the **[ENTER/STORE]** key. Note that as information is entered into the 411UDAC, the digits will scroll across the Programmer display from right to left.

```

  _7
 _77
_776
7764

```

A pause of up to 10 seconds between each number is allowed while entering the code. After pressing the **[ENTER/STORE]** key, the 411UDAC will be in Program Mode. A maximum of 10 minutes idle time is allowed at this point before beginning program entries and between each key stroke, otherwise, the unit will return to Normal Mode. All entries made prior to the 10 minute time-out are valid and are stored.

Once in Program Mode, the 411UDAC will:

- ✓ Light the DACT Trouble LED
- ✓ Activate Relay if programmed for DACT trouble
- ✓ Ignore all other keys other than those mentioned in this section
- ✓ Display **00_F** on the Programmer display
- ✓ Continue to communicate any events not previously acknowledged at a central station prior to entering Programming Mode
- ✓ Communicate an 'Off Normal' event to the Central Station
- ✓ Turn off piezo

While in Program Mode, the first three locations on the left of the Programmer display represent the memory address and the last location (farthest right) represents the contents of the memory address. The first address displayed is shown below:

```

  00_F
(address) (data)

```

Certain program items will be locked from editing if the communicator is active (dialing, transmitting, etc.). These programming locations are '00-19' Primary Central Station Phone Number, '20' Primary Central Station Communications Format, '21-24' Primary Central Station Account Code, '30-49' Secondary Central Station Phone Number, '50' Secondary Central Station Communications Format, '51-54' Secondary Central Station Account Code, '61' Central Station Backup Reporting and '145-end' Event Codes.

To unlock these locations, either wait until the communicator stops transmitting or disable the communicator via address location 64 by changing the content of this address to '0.'

When desired changes have been completed, exit Programming Mode by pressing the **MODE** key, followed by the 4-digit code for an alternate mode and then the **[ENTER/STORE]** key. During Program Mode, if no key is pressed within 10 minutes, the unit will revert to Normal Mode.

The Programmer cable should not be removed from the 411UDAC unless the unit is in Normal Mode. If the Programmer cable is removed while the 411UDAC is in a Mode other than Normal Mode, the communicator will automatically revert to Normal Mode following a 10 minute time-out period. Note that if the Programmer is in Troubleshoot Mode when the cable is removed, the 411UDAC will revert to Normal Mode following a 20 minute time-out period.

3.4.1 DACT Programming

Primary Central Station Phone Number (00 - 19)

The first twenty addresses (00 - 19) are factory set to 'F' (00_F to 19_F). Programming is done as follows:

- ✓ If your phone number is 484-7161, press 4.
- ✓ The display will read 00_4.
- ✓ Press [ENTER/STORE] to save the entry to memory and increment to the next address 01_F.
- ✓ Enter the remaining numbers in their respective addresses as shown below:

Entry	4	8	4	7	1	6	1	F	F	F	F	F	F	F	F	F	F	F	F	
Address	00	01	02	03	04	05	06	07	08	09	10	11	12	13	14	15	16	17	18	19

Valid entries for both the primary and secondary phone numbers are 0 to 9 and A to F with the numeric digits as dialed numbers and the hexadecimal digits representing the following functions:

- A = * on a Touch-Tone phone keypad
- B = # on a Touch-Tone phone keypad
- C = look for secondary dial tone for up to two seconds (then dial anyway)
- D = three second pause
- E = five second pause
- F = end of phone number (Note: F must remain in all unused phone number addresses)

If the first digit of the Primary Central Station Phone Number remains 'F' and the digital communicator is enabled for transmission to a Central Station, a primary phone number fault will be generated. The phone number must begin with a digit other than 'F.'

New FCC regulations allow extra digits to the CIC (Carrier ID Code), to identify the long distance carrier. The expanded phone number field of 20 digits facilitates this function. Simply enter the digits required by the telephone company if desired.

Primary Central Station Number Communication Format (20)

One location is needed to select the Communication Format to the primary phone number. Address 20 is used for this purpose. The factory default setting for this address is 'E', which is Contact ID Format. You may enter '0' through 'D' in place of the default, then press [ENTER/STORE]. Choose from the list of formats below:

- 0: 4+1 Ademco Express Standard, DTMF, 1400/2300 ACK
- 1: 4+2 Ademco Express Standard, DTMF, 1400/2300 ACK
- 2: 3+1 Standard 1800 Hz Carrier, 2300 Hz ACK
- 3: 3+1 Expanded 1800 Hz Carrier, 2300 Hz ACK
- 4: 3+1 Standard 1900 Hz Carrier, 1400 Hz ACK
- 5: 3+1 Expanded 1900 Hz Carrier, 1400 Hz ACK
- 6: 4+1 Standard 1800 Hz Carrier, 2300 Hz ACK
- 7: 4+1 Expanded 1800 Hz Carrier, 2300 Hz ACK
- 8: 4+1 Standard 1900 Hz Carrier, 1400 Hz ACK

- 9: 4+1 Expanded 1900 Hz Carrier, 1400 Hz ACK
- A: 4+2 Standard 1800 Hz Carrier, 2300 Hz ACK
- B: 4+2 Expanded 1800 Hz Carrier, 2300 Hz ACK
- C: 4+2 Standard 1900 Hz Carrier, 1400 Hz ACK
- D: 4+2 Expanded 1900 Hz Carrier, 1400 Hz ACK
- E: Contact ID, DTMF, 1400/2300 ACK
- F: Future use

Consult the Central Station for proper Format selection. For any Format chosen, all event codes are automatically programmed by the 411UDAC. Refer to Table 3.1, "Ademco Contact ID Format - Primary," on page 37, Table 3.2, "4+2 Standard and 4+2 Express Formats - Primary," on page 38 and Table 3.3, "All 3+1, 4+1 and 4+2 Expanded Formats - Primary," on page 39.

Event Codes - Setting Entries

The Format selected in address 20 will cause the 411UDAC to automatically program addresses 145 - 228 with the factory default settings. Any of the Event Code settings may be altered. Consult your Central Station prior to altering the event code settings. An entry of all zeros for any event code will cause the communicator to NOT transmit the report. *Transmission of reports to either or both Central Station phone numbers may be disabled.*

Upon accessing the first event code address (address 145) shown in Table 3.2, the following may be displayed on the Programmer 7-Segment Display, if the corresponding Format was selected in address 20.

1451
(address) (data)

The first three locations on the left of the Programmer display represent the memory address **145** of the Format previously selected in address 20. The last location **1** (farthest right) represents the contents of memory address **145** (which is the first digit of the event code).

The following Tables list the data which is automatically programmed for each Format that can be selected in address 20. The addresses shown in each Table contain the Setting data which is automatically programmed by the 411UDAC. To change the value, key in the new digit and then press the [ENTER/STORE] key to save the new value. Use the **Up** and **Down Arrow** keys to increment to the next address or decrement to the previous address.

Ademco Contact ID Format Primary Central Station Event Codes

If 'E' is entered for address 20, the following data is automatically programmed for the Primary Central Station phone number event codes. Enter '000' for the Setting to disable the report to the Central Station. The Channel # is not programmable.

<u>Address</u>	<u>Description</u>	<u>Setting</u>	<u>Channel/Input #</u>
145 - 147	Primary # Input Channel 1 Active Event Code	111	001
148 - 150	Primary # Input Channel 2 Active Event Code	115	002
151 - 153	Primary # Input Channel 3 Active Event Code	111	003
154 - 156	Primary # Input Channel 4 Active Event Code	115	004
157 - 159	Primary # Input Channel 1 Fault Event Code	380	001
160 - 162	Primary # Input Channel 2 Fault Event Code	380	002
163 - 165	Primary # Input Channel 3 Fault Event Code	380	003
166 - 168	Primary # Input Channel 4 Fault Event Code	380	004
169 - 171	Primary # AC Voltage Fault Event Code	301	000
172 - 174	Primary # Earth Fault Event Code	310	000

Table 3.1 Ademco Contact ID Format - Primary

<u>Address</u>	<u>Description</u>	<u>Setting</u>	<u>Channel/Input #</u>
175 - 177	Primary # Low Battery Fault Event Code	302	000
178 - 180	Primary # No Battery Fault Event Code	311	000
181 - 183	Primary # Phone Line 1 Voltage Fault Event Code	351	000
184 - 186	Primary # Phone Line 2 Voltage Fault Event Code	352	000
187 - 189	Primary # NAC Fault Event Code	321	000
190 - 192	Primary # Charger Fault Event Code	300	000
193 - 195	Primary # Phone Number 1 Communication Fault Event Code	354	001
196 - 198	Primary # Phone Number 2 Communication Fault Event Code	354	002
199 - 201	Primary # System Off Normal Fault Event Code	308	000
202 - 204	Primary # System Test Message	602	000
205 - 207	Primary # System Abnormal Test Message	608	000
208 - 210	Primary # Upload/Download Request Code	411	000
211 - 213	Primary # Upload Successful Code	416	000
214 - 216	Primary # Download Successful Code	412	000
217 - 219	Primary # Upload/Download Failed Code	413	000

Table 3.1 Ademco Contact ID Format - Primary

4+2 Standard and 4+2 Express Formats Primary Central Station Event Codes

If '1, A or C' is entered for address 20, the following data is automatically programmed for the Primary Central Station phone number event codes. Enter '00' for the Setting to disable the report to the Central Station.

<u>Address</u>	<u>Description</u>	<u>Setting</u>
145 - 146	Primary # Input Channel 1 Active Event Code	11
147 - 148	Primary # Input Channel 2 Active Event Code	12
149 - 150	Primary # Input Channel 3 Active Event Code	13
151 - 152	Primary # Input Channel 4 Active Event Code	14
153 - 154	Primary # Input Channel 1 Fault Event Code	F1
155 - 156	Primary # Input Channel 2 Fault Event Code	F2
157 - 158	Primary # Input Channel 3 Fault Event Code	F3
159 - 160	Primary # Input Channel 4 Fault Event Code	F4
161 - 162	Primary # AC Fault Event Code	92
163 - 164	Primary # Earth Fault Event Code	61
165 - 166	Primary # Low Battery Fault Event Code	62
167 - 168	Primary # No Battery Fault Event Code	63
169 - 170	Primary # Phone Line 1 Voltage Fault Event Code	64
171 - 172	Primary # Phone Line 2 Voltage Fault Event Code	65
173 - 174	Primary # NAC Fault Event Code	66
175 - 176	Primary # Charger Fault Event Code	47
177 - 178	Primary # Phone Number 1 Communication Fault Event Code	6A
179 - 180	Primary # Phone Number 2 Communication Fault Event Code	6B
181 - 182	Primary # System Off Normal Fault Event Code	6F
183 - 184	Primary # Input Channel 1 Active Restore Code	E1
185 - 186	Primary # Input Channel 2 Active Restore Code	E2
187 - 188	Primary # Input Channel 3 Active Restore Code	E3
189 - 190	Primary # Input Channel 4 Active Restore Code	E4
191 - 192	Primary # Input Channel 1 Fault Restore Code	D1
193 - 194	Primary # Input Channel 2 Fault Restore Code	D2
195 - 196	Primary # Input Channel 3 Fault Restore Code	D3

Table 3.2 4+2 Standard and 4+2 Express Formats - Primary

<u>Address</u>	<u>Description</u>	<u>Setting</u>
197 - 198	Primary # Input Channel 4 Fault Restore Code	D4
199 - 200	Primary # AC Voltage Fault Restore Code	93
201 - 202	Primary # Earth Fault Restore Code	A1
203 - 204	Primary # Low Battery Fault Restore Code	A2
205 - 206	Primary # No Battery Fault Restore Code	A3
207 - 208	Primary # Phone Line 1 Voltage Fault Restore Code	A4
209 - 210	Primary # Phone Line 2 Voltage Fault Restore Code	A5
211 - 212	Primary # NAC Fault Restore Code	A6
213 - 214	Primary # Charger Fault Restore Code	57
215 - 216	Primary # Phone Number 1 Communication Fault Restore Code	AA
217 - 218	Primary # Phone Number 2 Communication Fault Restore Code	AB
219 - 220	Primary # System Off Normal Restore Code	AF
221 - 222	Primary # System Test Message	99
223 - 224	Primary # System Abnormal Test Message	91
225 - 226	Primary # Upload/Download Request Code	71
227 - 228	Primary # Upload Successful Code	72
229 - 230	Primary # Download Successful Code	73
231 - 232	Primary # Upload/Download Failed Code	74

Table 3.2 4+2 Standard and 4+2 Express Formats - Primary

All 3+1, 4+1 and 4+2 Expanded Formats Primary Central Station Event Codes

If '0, 2, 3, 4, 5, 6, 7, 8, 9, B or D' is entered for address 20, the following data is automatically programmed for the Primary Central Station phone number event codes. Enter '0' for the Setting to disable the report to the Central Station.

<u>Address</u>	<u>Description</u>	<u>Setting</u>
145	Primary # Input Channel 1 Active Event Code	1
146	Primary # Input Channel 2 Active Event Code	1
147	Primary # Input Channel 3 Active Event Code	1
148	Primary # Input Channel 4 Active Event Code	1
149	Primary # Input Channel 1 Fault Event Code	F
150	Primary # Input Channel 2 Fault Event Code	F
151	Primary # Input Channel 3 Fault Event Code	F
152	Primary # Input Channel 4 Fault Event Code	F
153	Primary # AC Power Fault Event Code	9
154	Primary # Earth Fault Event Code	6
155	Primary # Low Battery Fault Event Code	6
156	Primary # No Battery Fault Event Code	6
157	Primary # Phone Line 1 Voltage Fault Event Code	6
158	Primary # Phone Line 2 Voltage Fault Event Code	6
159	Primary # NAC Fault Event Code	6
160	Primary # Charger Fault Event Code	4
161	Primary # Phone Number 1 Communication Fault Event Code	6
162	Primary # Phone Number 2 Communication Fault Event Code	6
163	Primary # System Off Normal Fault Code	6
164	Primary # Input Channel 1 Active Restore Code	E
165	Primary # Input Channel 2 Active Restore Code	E
166	Primary # Input Channel 3 Active Restore Code	E
167	Primary # Input Channel 4 Active Restore Code	E
168	Primary # Input Channel 1 Fault Restore Code	D
169	Primary # Input Channel 2 Fault Restore Code	D
170	Primary # Input Channel 3 Fault Restore Code	D

Table 3.3 All 3+1, 4+1 and 4+2 Expanded Formats - Primary

<u>Address</u>	<u>Description</u>	<u>Setting</u>
171	Primary # Input Channel 4 Fault Restore Code	D
172	Primary # AC Voltage Fault Restore Code	9
173	Primary # Earth Fault Restore Code	A
174	Primary # Low Battery Fault Restore Code	A
175	Primary # No Battery Fault Restore Code	A
176	Primary # Phone Line 1 Voltage Fault Restore Code	A
177	Primary # Phone Line 2 Voltage Fault Restore Code	A
178	Primary # NAC Fault Restore Code	A
179	Primary # Charger Fault Restore Code	
180	Primary # Phone Number 1 Communication Fault Restore Code	A
181	Primary # Phone Number 2 Communication Fault Restore Code	A
182	Primary # System Off Normal Restore Code	A
183	Primary # System Test Message	9
184	Primary # System Abnormal Test Message	F*
185	Primary # Upload/Download Request Code	7
186	Primary # Upload Successful Code	7
187	Primary # Download Successful Code	7
188	Primary # Upload/Download Failed Code	7

Table 3.3 All 3+1, 4+1 and 4+2 Expanded Formats - Primary

* For Formats 'B' and 'D', this address is defaulted to '9' instead of 'F.'

Primary Central Station Number Account Code (21 - 24)

The four locations at addresses 21 - 24 default to all '0's. Valid entries are 0 - 9 and A - F. The number of digits entered must match the format selection. If programming '2, 3, 4 or 5' into address 20, enter three digits (one digit each in locations 21, 22 and 23 - location 24 is ignored). If programming '0, 1, 6, 7, 8, 9, A, B, C, D or E' into address 20, enter four digits (one each in locations 21, 22, 23 and 24).

Primary Central Station Number 24 Hour Test Time (25 - 28)

Use military time when entering the 24 hour 'test' time. The 24 hour test report to phone number 1 takes up four locations, from addresses 25 - 28. The default is 00:00 (12:00 midnight). The limits for each location are as follows (do not use values of A - F as entries).

25: enter 0, 1 or 2

26: enter 0 - 9

27: enter 0 - 5

28: enter 0 - 9

Primary Central Station Number 24/12/8/6 Hour Test Time Interval (29)

The test report sent to the Primary phone number may be sent every 6, 8, 12 or 24 hours. If the message is to be sent every 24 hours, leave the factory default entry of '0'. If other test report times are needed, enter 1 = 12 hour, 2 = 8 hour or 3 = 6 hour.

Secondary Central Station Phone Number (30 - 49)

Addresses **30 - 49** are factory set to 'F' (**30_F to 49_F**). Programming is typically done as follows:

- ✓ If your phone number is 484-7161, press 4.
- ✓ The display will read **30_4**.
- ✓ Press **[ENTER/STORE]** to save the entry to memory and increment to the next address **31_F**.

✓ Enter the remaining numbers in their respective addresses as shown below:

Entry	4	8	4	7	1	6	1	F	F	F	F	F	F	F	F	F	F	F	F	
Address	30	31	32	33	34	35	36	37	38	39	40	41	42	43	44	45	46	47	48	49

Valid entries for both the primary and secondary phone numbers are 0 to 9 and A to F with the numeric digits as dialed numbers and the hexadecimal digits representing the following functions:

- A = * on a Touch-Tone phone keypad
- B = # on a Touch-Tone phone keypad
- C = look for secondary dial tone for up to two seconds (then dial anyway)
- D = three second pause
- E = five second pause
- F = end of phone number (Note: F must remain in all unused phone number addresses)

If the first digit of the Secondary Central Station Phone Number remains 'F' and the digital communicator is enabled for transmission to a Central Station, a secondary phone number fault will be generated. The phone number must begin with a digit other than 'F.'

Secondary Central Station Number Communication Format (50)

One location is needed to select the Communication Format to the secondary phone number. Address 50 is used for this purpose. The factory default setting for this address is 'E', which is Contact ID Format. You may enter '0' through 'D' in place of the default, then press [ENTER/STORE]. Choose from the list of formats below:

- 0: 4+1 Ademco Express Standard, DTMF, 1400/2300 ACK
- 1: 4+2 Ademco Express Standard, DTMF, 1400/2300 ACK
- 2: 3+1 Standard 1800 Hz Carrier, 2300 Hz ACK
- 3: 3+1 Expanded 1800 Hz Carrier, 2300 Hz ACK
- 4: 3+1 Standard 1900 Hz Carrier, 1400 Hz ACK
- 5: 3+1 Expanded 1900 Hz Carrier, 1400 Hz ACK
- 6: 4+1 Standard 1800 Hz Carrier, 2300 Hz ACK
- 7: 4+1 Expanded 1800 Hz Carrier, 2300 Hz ACK
- 8: 4+1 Standard 1900 Hz Carrier, 1400 Hz ACK
- 9: 4+1 Expanded 1900 Hz Carrier, 1400 Hz ACK
- A: 4+2 Standard 1800 Hz Carrier, 2300 Hz ACK
- B: 4+2 Expanded 1800 Hz Carrier, 2300 Hz ACK
- C: 4+2 Standard 1900 Hz Carrier, 1400 Hz ACK
- D: 4+2 Expanded 1900 Hz Carrier, 1400 Hz ACK
- E: Contact ID, DTMF, 1400/2300 ACK
- F: Future use

The Format selected in address 50 will cause the 411UDAC to automatically program addresses 229 - 312 with the factory default settings. Any of the Event Code settings may be altered. Consult your Central Station prior to altering the event code settings. An entry of all zeros for any event code will cause the communicator to NOT transmit the report. *Transmission of reports to either or both Central Station phone numbers may be disabled.*

Refer to “Central Station Communications” on page 54 for information on Format reporting.

Upon accessing the first event code address which is 229 (Table 3.5, “4+2 Standard and 4+2 Express Formats - Secondary,” on page 43), the following may be displayed on the Programmer’s 7-Segment Display, if the corresponding Format was selected in address 50.

2291
(address) (data)

The first three locations on the left of the Programmer’s display represent the memory address **229**. The last location **1** (farthest right) represents the contents of memory address **229** which is the first digit of the event code.

The following Tables list the data which is automatically programmed for each Format that can be selected in address 50. The addresses shown in each Table contain the event code Setting data which is automatically programmed by the 411UDAC. To change the value, key in the new digits and then press the [ENTER/STORE] key to save the new value. Use the **Up** and **Down Arrow** keys to increment to the next address or decrement to the previous address.

Ademco Contact ID Format Secondary Central Station Event Codes

If ‘E’ is entered for address 50, the following data is automatically programmed for the Secondary Central Station phone number event codes. Enter '000' for the Setting to disable the report to the Central Station.

<u>Address</u>	<u>Description</u>	<u>Setting</u>	<u>Channel/Input #</u>
233 - 235	Secondary # Input Channel 1 Active Event Code	111	001
236 - 238	Secondary # Input Channel 2 Active Event Code	115	002
239 - 241	Secondary # Input Channel 3 Active Event Code	111	003
242 - 244	Secondary # Input Channel 4 Active Event Code	115	004
245 - 247	Secondary # Input Channel 1 Fault Event Code	380	001
248 - 250	Secondary # Input Channel 2 Fault Event Code	380	002
251 - 253	Secondary # Input Channel 3 Fault Event Code	380	003
254 - 256	Secondary # Input Channel 4 Fault Event Code	380	004
257 - 259	Secondary # AC Voltage Fault Event Code	301	000
260 - 262	Secondary # Earth Fault Event Code	310	000
263 - 265	Secondary # Low Battery Fault Event Code	302	000
266 - 268	Secondary # No Battery Fault Event Code	311	000
269 - 271	Secondary # Phone Line 1 Voltage Fault Event Code	351	000
272 - 274	Secondary # Phone Line 2 Voltage Fault Event Code	352	000
275 - 277	Secondary # NAC Fault Event Code	321	000
278 - 280	Secondary # Charger Fault Event Code	300	000
281 - 283	Secondary # Phone Number 1 Communication Fault Event Code	354	001
284 - 286	Secondary # Phone Number 2 Communication Fault Event Code	354	002
287 - 289	Secondary # System Off Normal Fault Event Code	308	000
290 - 292	Secondary # System Test Message	602	000
293 - 295	Secondary # System Abnormal Test Message	608	000
296 - 298	Secondary # Upload/Download Request Code	411	000
299 - 301	Secondary # Upload Successful Code	416	000
302 - 304	Secondary # Download Successful Code	412	000
305 - 307	Secondary # Upload/Download Failed Code	413	000

Table 3.4 Ademco Contact ID Format - Secondary

4+2 Standard and 4+2 Express Formats Secondary Central Station Event Codes

If 1, A or C is entered for address 50, the following data is automatically programmed for the Secondary Central Station phone number event codes. Enter '00' for the Setting to disable the report to the Central Station.

<u>Address</u>	<u>Description</u>	<u>Setting</u>
233 - 234	Secondary # Input Channel 1 Active Event Code	11
235 - 236	Secondary # Input Channel 2 Active Event Code	12
237 - 238	Secondary # Input Channel 3 Active Event Code	13
239 - 240	Secondary # Input Channel 4 Active Event Code	14
241 - 242	Secondary # Input Channel 1 Fault Event Code	F1
243 - 244	Secondary # Input Channel 2 Fault Event Code	F2
245 - 246	Secondary # Input Channel 3 Fault Event Code	F3
247 - 248	Secondary # Input Channel 4 Fault Event Code	F4
249 - 250	Secondary # AC Fault Event Code	92
251 - 252	Secondary # Earth Fault Event Code	61
253 - 254	Secondary # Low Battery Fault Event Code	62
255 - 256	Secondary # No Battery Fault Event Code	63
257 - 258	Secondary # Phone Line 1 Voltage Fault Event Code	64
259 - 260	Secondary # Phone Line 2 Voltage Fault Event Code	65
261 - 262	Secondary # NAC Fault Event Code	66
263 - 264	Secondary # Charger Fault Event Code	47
265 - 266	Secondary # Phone Number 1 Communication Fault Event Code	6A
267 - 268	Secondary # Phone Number 2 Communication Fault Event Code	6B
269 - 270	Secondary # System Off Normal Fault Event Code	6F
271 - 272	Secondary # Input Channel 1 Active Restore Code	E1
273 - 274	Secondary # Input Channel 2 Active Restore Code	E2
275 - 276	Secondary # Input Channel 3 Active Restore Code	E3
277 - 278	Secondary # Input Channel 4 Active Restore Code	E4
279 - 280	Secondary # Input Channel 1 Fault Restore Code	D1
281 - 282	Secondary # Input Channel 2 Fault Restore Code	D2
283 - 284	Secondary # Input Channel 3 Fault Restore Code	D3
285 - 286	Secondary # Input Channel 4 Fault Restore Code	D4
287 - 288	Secondary # AC Voltage Fault Restore Code	93
289 - 290	Secondary # Earth Fault Restore Code	A1
291 - 292	Secondary # Low Battery Fault Restore Code	A2
293 - 294	Secondary # No Battery Fault Restore Code	A3
295 - 296	Secondary # Phone Line 1 Voltage Fault Restore Code	A4
297 - 298	Secondary # Phone Line 2 Voltage Fault Restore Code	A5
299 - 300	Secondary # NAC Fault Restore Code	A6
301 - 302	Secondary # Charger Fault Restore Code	57
303 - 304	Secondary # Phone Number 1 Communication Fault Restore Code	AA
305 - 306	Secondary # Phone Number 2 Communication Fault Restore Code	AB
307 - 308	Secondary # System Off Normal Restore Code	AF
309 - 310	Secondary # System Test Message	99
311 - 312	Secondary # System Abnormal Test Message	91
313 - 314	Secondary # Upload/Download Request Code	71
315 - 316	Secondary # Upload Successful Code	72
317 - 318	Secondary # Download Successful Code	73
319 - 320	Secondary # Upload/Download Failed Code	74

Table 3.5 4+2 Standard and 4+2 Express Formats - Secondary

All 3+1, 4+1 and 4+2 Expanded Formats Secondary Central Station Event Codes

If 0, 2, 3, 4, 5, 6, 7, 8, 9, B or D is entered for address 50, the following data is automatically programmed for the Secondary Central Station phone number event codes. Enter '0' for the Setting to disable the report to the Central Station.

<u>Address</u>	<u>Description</u>	<u>Setting</u>
233	Secondary # Input Channel 1 Active Event Code	1
234	Secondary # Input Channel 2 Active Event Code	1
235	Secondary # Input Channel 3 Active Event Code	1
236	Secondary # Input Channel 4 Active Event Code	1
237	Secondary # Input Channel 1 Fault Event Code	F
238	Secondary # Input Channel 2 Fault Event Code	F
239	Secondary # Input Channel 3 Fault Event Code	F
240	Secondary # Input Channel 4 Fault Event Code	F
241	Secondary # AC Power Fault Event Code	9
242	Secondary # Earth Fault Event Code	6
243	Secondary # Low Battery Fault Event Code	6
244	Secondary # No Battery Fault Event Code	6
245	Secondary # Phone Line 1 Voltage Fault Event Code	6
246	Secondary # Phone Line 2 Voltage Fault Event Code	6
247	Secondary # NAC Fault Event Code	6
248	Secondary # Charger Fault Event Code	4
249	Secondary # Phone Number 1 Communication Fault Event Code	6
250	Secondary # Phone Number 2 Communication Fault Event Code	6
251	Secondary # System Off Normal Fault Code	6
252	Secondary # Input Channel 1 Active Restore Code	E
253	Secondary # Input Channel 2 Active Restore Code	E
254	Secondary # Input Channel 3 Active Restore Code	E
255	Secondary # Input Channel 4 Active Restore Code	E
256	Secondary # Input Channel 1 Fault Restore Code	D
257	Secondary # Input Channel 2 Fault Restore Code	D
258	Secondary # Input Channel 3 Fault Restore Code	D
259	Secondary # Input Channel 4 Fault Restore Code	D
260	Secondary # AC Voltage Fault Restore Code	9
261	Secondary # Earth Fault Restore Code	A
262	Secondary # Low Battery Fault Restore Code	A
263	Secondary # No Battery Fault Restore Code	A
264	Secondary # Phone Line 1 Voltage Fault Restore Code	A
265	Secondary # Phone Line 2 Voltage Fault Restore Code	A
266	Secondary # NAC Fault Restore Code	A
267	Secondary # Charger Fault Restore Code	5
268	Secondary # Phone Number 1 Communication Fault Restore Code	A
269	Secondary # Phone Number 2 Communication Fault Restore Code	A
270	Secondary # System Off Normal Restore Code	A
271	Secondary # System Test Message	9
272	Secondary # System Abnormal Test Message	F*
273	Secondary # Upload/Download Request Code	7
274	Secondary # Upload Successful Code	7
275	Secondary # Download Successful Code	7
276	Secondary # Upload/Download Failed Code	7

Table 3.6 All 3+1, 4+1 and 4+2 Expanded Formats - Secondary

* For Formats 'B' and 'D', this address is defaulted to '9' instead of 'F.'

Secondary Central Station Number Account Code (51 - 54)

The four locations at addresses 51 - 54 default to all '0's. Valid entries are 0 - 9 and A - F. The number of digits entered must match the format selection. If programming '2, 3, 4 or 5' into address 50, enter three digits (one digit each in locations 51, 52 and 53 - location 54 is ignored). If programming '0, 1, 6, 7, 8, 9, A, B, C, D or E' into address 50, enter four digits (one each in locations 51, 52, 53 and 54).

Secondary Central Station Number 24 Hour Test Time (55 - 58)

Use military time when entering the 24 hour 'test' time. The 24 hour test report to phone number 1 takes up four locations, from addresses 55 - 58. The default is 00:00 (12:00 midnight). The limits for each location are as follows (do not use values of A - F as entries):

55: enter 0, 1 or 2

56: enter 0 - 9

57: enter 0 - 5

58: enter 0 - 9

Secondary Central Station Number 24/12/8/6 Hour Test Time Interval (59)

The test report sent to the Secondary phone number may be sent every 6, 8, 12 or 24 hours. If the message is to be sent every 24 hours, leave the factory default entry of '0'. If other test report times are needed, enter 1 = 12 hour, 2 = 8 hour or 3 = 6 hour.

AC Loss Reporting Delay (60)

Enter a digit of 0 - 9 or A - F corresponding to the number of hours to be delayed in reporting the loss of AC power. The factory default is '2' for 2 hours. The valid entries are '0' = no delay; '1' = 1 hours; '2' = 2 hours; '3' = 6 hours; '4' = 7 hours; '5' = 8 hours; '6' = 9 hours; '7' = 10 hours; '8' = 11 hours; '9' = 12 hours; 'A' = 13 hours; 'B' = 14 hours; 'C' = 15 hours; 'D' = 16 hours; 'E' = 17 hours; 'F' = 18 hours.

UL requires a 1-3 hour delay.

Backup Reporting (61)

Leaving address 61 at '0' means that reports will be transmitted to the secondary Central Station phone number only if attempts to communicate to the primary Central Station phone number are unsuccessful. Programming a '1' causes all reports to be transmitted to both the primary and secondary Central Station phone numbers. Programming a '2' causes reports to go to the first available receiver.

Do not alter this entry while the digital communicator is active!

Reserved for Future Use (62)

DACT Trouble Reminder (63)

The factory default entry of '0' in address location 63 disables the trouble reminder feature. Selecting '1' for location 63 will cause a reminding beep (after the Silence switch is pressed) every 15 seconds for active alarms and every two minutes during a DACT trouble condition. The beeps from the onboard piezo sounder will occur until the alarm or DACT fault is cleared. The piezo sounder will begin beeping at a rate of one second On and one second Off after 24 hours unless the DACT fault has been cleared.

Operational Mode Selection (64)

The factory default setting is '0' for latching inputs and the onboard communicator disabled. This prevents the unit from transmitting status information to the Central Station(s).

Address 64 Setting	411UDAC Operational Mode	411UDAC Function
0	Stand-alone/Communicator Disabled	latching inputs/onboard communicator disabled
1	Stand-alone/Communicator Enabled	latching inputs/onboard communicator enabled
2	Slave/Communicator Enabled	non-latching inputs/onboard communicator enabled
3	Slave/Communicator Disabled	non-latching inputs/onboard communicator disabled

Table 3.7 411UDAC Operational Modes

Input Channel 1 Function Selection (65)¹

Factory default for Channel 1 is '0' for activation on fire alarm (4-wire smoke). Enter '1' for pull station; '2' for normally open contact device; '3' for host panel trouble; '4' for fire supervisory; '5' for fire supervisory autoresettable; '6' for waterflow silenceable; '7' for waterflow nonsilenceable.

Input Channel 2 Function Selection (66)¹

Factory default for Channel 2 is '1' for pull station. Enter '2' for normally open contact device; '3' for host panel trouble; '4' for fire supervisory; '5' for fire supervisory autoresettable; '6' for waterflow silenceable; '7' for waterflow nonsilenceable.

Note that '0' is not a valid entry.

Input Channel 3 Function Selection (67)¹

Factory default for Channel 3 is '0' for activation on fire alarm (4-wire smoke). Enter '1' for pull station; '2' for normally open contact device; '3' for host panel trouble; '4' for fire supervisory; '5' for fire supervisory autoresettable; '6' for waterflow silenceable; '7' for waterflow nonsilenceable.

Input Channel 4 Function Selection (68)¹

Factory default for Channel 4 is '1' for pull station. Enter '2' for normally open contact device; '3' for host panel trouble; '4' for fire supervisory; '5' for fire supervisory autoresettable; '6' for waterflow silenceable; '7' for waterflow nonsilenceable.

Note that '0' is not a valid entry.

Input Channel 1 Delay Timer (69 - 71)²

The Delay Timer is used to delay digital communicator transmission to a Central Station when the Input Channel is activated. Input Channel 1 Delay Timer is factory set to '000' seconds for no delay. The timer may be programmed for a delay of from 0 to 179 seconds. *Inputs programmed for fire alarm, pull station, host control panel trouble and fire supervisory, must not be delayed. A delay, therefore, cannot be selected for inputs programmed for these fire applications.* If the input is set for a waterflow function, the delay timer will also delay activation of the relay, piezo sounder and LEDs.

Input Channel 2 Delay Timer (72 - 74)²

The Delay Timer is used to delay digital communicator transmission to a Central Station when the Input Channel is activated. Input Channel 2 Delay Timer is factory set to '000' seconds for no delay. The timer may be programmed for a delay of from 0 to 179 seconds. *Inputs programmed for fire alarm, pull station, host control panel trouble and fire supervisory, must not be delayed. A delay, therefore, cannot be selected for inputs programmed for these fire applications.* If the input is set for a waterflow function, the delay timer will also delay activation of the relay, piezo sounder and LEDs.

1. Changing the input function will automatically change the corresponding Primary and Secondary event codes to reflect the new input function. The Communication Format should be programmed first, followed by the Input Channel Function. See "Events and Default Event Codes" on page 79.
2. This timer does not delay LED or Output Relay activation and is not used for channels programmed as AC Loss circuits.

Input Channel 3 Delay Timer (75 - 77)¹

The Delay Timer is used to delay digital communicator transmission to a Central Station when the Input Channel is activated. Input Channel 3 Delay Timer is factory set to '000' seconds for no delay. The timer may be programmed for a delay of from 0 to 179 seconds. *Inputs programmed for fire alarm, pull station, host control panel trouble and fire supervisory, must not be delayed. A delay, therefore, cannot be selected for inputs programmed for these fire applications.* If the input is set for a waterflow function, the delay timer will also delay activation of the relay, piezo sounder and LEDs.

Input Channel 4 Delay Timer (78 - 80)¹

The Delay Timer is used to delay digital communicator transmission to a Central Station when the Input Channel is activated. Input Channel 4 Delay Timer is factory set to '000' seconds for no delay. The timer may be programmed for a delay of from 0 to 179 seconds. *Inputs programmed for fire alarm, pull station, host control panel trouble and fire supervisory, must not be delayed. A delay, therefore, cannot be selected for inputs programmed for these fire applications.* If the input is set for a waterflow function, the delay timer will also delay activation of the relay, piezo sounder and LEDs.

Touchtone/Rotary Select for Primary Phone (81)

A '0' programmed in this address by the factory, triggers Touchtone dialing over the primary phone line. Select '1' for rotary dialing.

Make/Break Ratio for Primary Phone (82)

This address is used only if a '1' has been programmed for address 81. The Make/Break ratio is factory set to '0' which is 67/33 ratio, but may be changed to '1' which is 62/38 ratio.

Touchtone/Rotary Select for Secondary Phone (83)

A '0' programmed in this address by the factory, triggers Touchtone dialing over the secondary phone line. Select '1' for rotary dialing.

Make/Break Ratio for Secondary Phone (84)

This address is used only if a '1' has been programmed for address 83. The Make/Break ratio is factory set to '0' which is 67/33 ratio, but may be changed to '1' which is 62/38 ratio.

Output Relay #1 Enable (85)

The factory default setting for Output Relay #1 is '0' for disabled. Enter '1' to enable the relay.

Output Relay #1 Function Selections (86)

The Output Relay can be programmed to activate for any one of six conditions. The factory default for address 86 is '0' for activation on fire alarm. Program a '1' for host panel trouble; '2' for DACT trouble; '3' for latching fire supervisory; '4' for autoresettable fire supervisory; '8' for total communication failure.

Output Relay #2 Enable (87)

The factory default setting for Output Relay #2 is '0' for disabled. Enter '1' to enable the relay.

Output Relay #2 Function Selections (88)

Output Relay #2 can be programmed to activate for any one of six conditions. The factory default for address 88 is '2' for activation on DACT trouble. Program a '0' for activation on fire alarm; '1' for host panel trouble; '3' for latching fire supervisory; '4' for autoresettable fire supervisory; '8' for total communication failure.

1. This timer does not delay LED or Output Relay activation and is not used for channels programmed as AC Loss circuits.

Reserved for Future Use (89)

Leave default setting of '0'

Panel Unlock (90)

The communicator must be unlocked to accept a remote upload/download. Leaving the default setting of '0' will require the unlock code **8655** be entered for each data transfer session (30 minute timeout). Enter '1' to keep the communicator in a permanent unlocked state.

Alarm Verification Enable (91)

Alarm verification works only on zones programmed as 4-wire smoke detector zones (i.e. zones 1 and 3). After detecting an alarm, the panel removes power from four-wire smoke zones, resetting all 4-wire smoke detectors. Power is reapplied and a 16 second restart period allows detectors to stabilize. During the retard/reset/restart period of 24 seconds, subsequent alarms by the same initiating zone are ignored. An alarm detected on any other 4-wire detector zone during the restart period will cause immediate verified alarms. A subsequent alarm on the initiating zone occurring within the confirmation time will cause a verified alarm.



NOTE: Mixing devices on zones designated as 4-wire smoke zones is not recommended. The communicator will not transmit a signal to the Central Station signifying that alarm verification is in progress.

During the alarm verification period, access to other modes of operation is prevented.

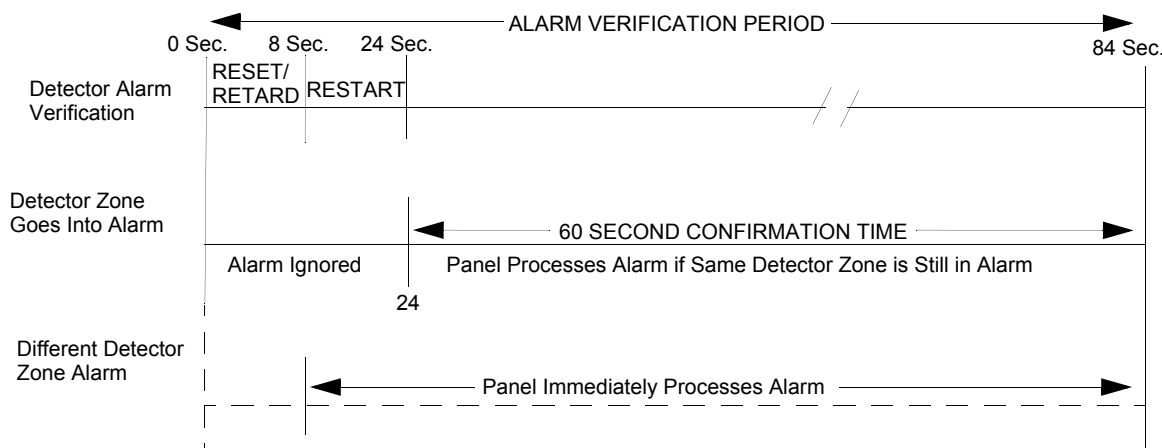

Figure 3.2 Verification Timing Diagram

Factory Default is no verification which is an entry of '0'. Entering '1' enables verification. Alarm Verification is ignored if the 411UDAC is configured for nonlatching Slave Communicator operation or Test Mode.



NOTE: Consult local Authority Having Jurisdiction (AHJ) prior to altering this address.

Silence Inhibit Notification Appliance Circuit (92)

Setting address 92 to '1' prevents the silencing or resetting of the Notification Appliance Circuit for one minute following an alarm. The factory default setting is '0' for no silence inhibit.

Autosilence Notification Appliance Circuit (93)

The Notification Appliance Circuit may be autosilenced after a programmed time interval between 5 and 30 minutes. Enter '1' for 5 minute autosilence; '2' for 10 minutes; '3' for 15 minutes; '4' for 20 minutes; '5' for 25 minutes; '6' for 30 minutes. The factory default is '0' for no autosilence.

Restoral Method (94)

Restoral Method refers to the *communication* of Restoral Events to a Central Station. It has no effect on the actual input circuit restoral itself.

- Typical Restoral Method - '0' entry programs the panel to transmit each input circuit restoral, as it occurs, to the Central Station. In Slave Mode, this means that as soon as an input restores, the communicator will immediately transmit the Restoral Event to the Central Station. In Stand-alone Mode, the restoral of inputs programmed as Autoresettable Supervisory will also cause the communicator to transmit a Restoral Event immediately. All other input types in Stand-alone Mode are latching and their restoral will not communicate a Restoral Event until the Reset Switch is pressed.
- Conditional Restoral Method #1 - '1' entry programs the panel to transmit each input circuit restoral, as it occurs, to the Central Station. In Slave Mode, this means that as soon as an input restores, the communicator will immediately transmit the Restoral Event to the Central Station. In Stand-alone Mode, the restoral of inputs programmed as Autoresettable Supervisory will also cause the communicator to transmit a Restoral Event immediately. All other input types in Stand-alone Mode are latching and the communication of their Restoral Events are dependent upon an after-reset condition.
The input circuit must be physically clear of an input short upon completion of the reset period. If, and only if, the input circuit is normal (clear of an input short) after the reset period will the communicator transmit a Restoral Event to the Central Station. If the input circuit remains active after the reset period, no transmission will take place.
- Conditional Restoral Method #2 - '2' entry programs the panel to transmit each input circuit restoral if, and only if, *all* input circuits are normal (clear of an input short). In Slave Mode, this means that as soon as *all* input circuits are restored, the communicator will transmit the Restoral Event(s) to the Central Station. In Stand-alone Mode, the restoral of inputs programmed as either Autoresettable Supervisory will cause the communicator to transmit a Restoral Event if, and only if, all input circuits are normal¹. All other input types in Stand-alone Mode are latching and the communication of their Restoral Events are dependent upon an after-reset condition. If, and only if, all input circuits are normal (clear of an input short) after the reset period will the communicator transmit a Restoral Event(s) to the Central Station. If *any* input circuit remains active after the reset period, no transmission will take place, *even if other input circuits are truly restored*.

1. Latching input circuits will never restore in Stand-alone Mode until the Reset Switch is pressed. If both an Autoresettable input circuit and a Latching input circuit are activated and subsequently cleared, only the Autoresettable input circuit will restore, but no transmission will occur to the Central Station since there is still an input circuit active (the Latching input circuit).

Table 3.8 describes the events that would take place after the reset period, according to each unique Communicator Restoral Method. It is assumed that an input circuit is active before reset.

Input Circuit After Reset	Typical Restoral Method	Conditional Restoral Method #1	Conditional Restoral Method #2
SHORTED	All local annunciation of the active event stops. The short is rediscovered after reset period and local annunciation begins again.* The panel communicates: 1. A Restoral Event 2. An Active Event†	All local annunciation of the active event stops. The short is rediscovered after reset period and local annunciation begins again.* The panel communicates nothing because this input is still in an active state after reset.	All local annunciation of the active event stops. The short is rediscovered after reset period and local annunciation begins again.* The panel communicates nothing because an input (can be any input) is still in an active state after reset.
NOT SHORTED	All local annunciation of the active event stops. The circuit is found to be in a normal state. The panel communicates: 1. A Restoral Event	All local annunciation of the active event stops. The circuit is found to be in a normal state. The panel communicates: 1. A Restoral Event	All local annunciation of the active event stops. The circuit is found to be in a normal state. <i>If, and only if, all input circuits are found to be in a normal state will the panel communicate:</i> 1. A Restoral Event Otherwise, the panel will communicate nothing.

Table 3.8 Restoral Methods

- * Local annunciation is dependent upon input circuit function. Inputs programmed as waterflow devices will not annunciate until the waterflow retard period has expired. Inputs programmed as 4-wire smoke devices, with the Alarm Verification feature enabled, will not annunciate until the alarm is verified.
- † Inputs programmed with a delay will not communicate the Active Event until the delay period has expired.

Coding, Notification Appliance Circuit (95)

Coding of the Notification Appliance Circuit is selectable as '0' for no coding (steady) or '1' for Temporal (½ second On, ½ second Off, ½ second On, ½ second Off, ½ second On, 1½ second Off). Factory default is '0' for no coding (steady). *Note that this NAC should only be used to supplement host panel NACs.*

Trouble Call Limit - Dialer Runaway Prevention (96)

Factory default setting of '0' in address 96, allows the digital communicator to call the Central Station each time any DACT trouble and any active Channel programmed for host panel trouble is detected by the 411UDAC. Programming a '1' in this address enables the Trouble Call Limit feature, which limits the number of 411UDAC and Input Channel Trouble calls to the Central Station to 10 calls for each unique trouble event within a 24 hour period. Separate limit counters keep track of each unique type of trouble (e.g. open input channel). To clear the limit counters, disable and then enable this location. Note that the number of phone line (communication) faults called to the Central Station are not limited by this feature. No subsequent restoral message is sent to the Central Station(s) for a particular trouble whose limit of 10 calls has been reached. Local DACT annunciation will still track the particular trouble and restoral.

Panel Identification Number (97 - 100)

The Panel Identification Number is a 4-digit code (valid digits are 0 to F) that is used to identify the installed panel. It is important to program this 4-digit code at the job site the first time that downloading is performed so that the called Service Terminal can identify the panel. The Factory default is '0000'. (Future Use).

Service Terminal 1 Phone Number (101 - 120)

Addresses 100 - 119 are reserved for the Service Terminal Number 1 phone number. Factory default is all 'F's. Valid entries are 0 - 9 plus A, B, C, D and E. Use 'F' to designate the end of the phone number. See "Remote Site Upload/Download" on page 60 for additional information.

Ring Count on Primary Phone Line (121 - 122)

Use this address to designate the number of rings allowed on the primary phone line prior to answering an incoming call from the Service Terminal. Factory default is '3' meaning the communicator will not answer an incoming call until 3 rings are detected. This entry may be programmed up to a maximum of '25' rings. A setting of '00' prevents the communicator from answering incoming calls.

FAX/Answer Machine, Primary Phone Line (123)

This entry is used when the primary phone line is being shared with a FAX, answering machine or other device. Factory default is '0' for no sharing of the primary phone line. An entry of '1' indicates that another device is sharing the primary phone line. The communicator will wait for three consecutive calls from the Service Terminal spaced 30 seconds apart, before responding. Sharing of phone lines requires the prior approval of the AHJ (Authority Having Jurisdiction).

Service Terminal 2 Phone Number (124 - 143)

Addresses 123 - 142 are reserved for the Service Terminal Number 2 phone number. Factory default is all 'F's. Valid entries are 0 - 9 plus A, B, C, D and E. Use 'F' to designate the end of the phone number. See "Remote Site Upload/Download" on page 60 for additional information.

Upload/Download Reports Sent to Secondary Central Station Phone #, Backup or Always (144)

Leaving address 144 programmed to the factory default setting of '0' means that reports for request for 'upload/download' and 'failed upload/download' will be sent to the secondary Central Station phone number only if attempts to the primary Central Station phone number are unsuccessful. Programming a '1' causes all reports to be transmitted to both primary and secondary phone numbers. Programming a '2' causes reports to be sent to the first available receiver.

Do not alter entry while the communicator is active.

Programming Event Code Settings (145 - 312)

Event Code Settings, corresponding to the Formats selected for the Primary Central Station phone number in address 20 and the Secondary Central Station phone number in address 50, are automatically set to factory default values. Refer to Table 3.1, "Ademco Contact ID Format - Primary," on page 37, Table 3.2, "4+2 Standard and 4+2 Express Formats - Primary," on page 38, and Table 3.3, "All 3+1, 4+1 and 4+2 Expanded Formats - Primary," on page 39 for format designated by address 20. Refer to Table 3.4, "Ademco Contact ID Format - Secondary," on page 42, Table 3.5, "4+2 Standard and 4+2 Express Formats - Secondary," on page 43, and Table 3.6, "All 3+1, 4+1 and 4+2 Expanded Formats - Secondary," on page 44 for format designated by address 50. The Event Code Settings can be altered. *Consult your Central Station prior to changing the event code settings.*

3.5 Default Mode

To return all program entries, including the upload/download secret password and time, to their factory original settings, perform the following steps only when the system is idle (i.e. the communicator is not active) and there are no active fire alarms or fire supervisories in the system:

Press the **MODE** key followed by the 4-digit code **3337** and press the **[ENTER/STORE]** key.

3337 spells DEFP (**DE**fault **P**rogramming) on a Touch-Tone® phone.

If an incorrect key is entered, reenter the proper 4-digit code before pressing the [ENTER/STORE] key. Within five seconds, repeat this entry by again pressing the **MODE** key followed by the 4-digit code **3337** and pressing the [ENTER/STORE] key. The display will read **LinP**. Enter your 4-digit password. When reprogramming is complete, the real time clock will display.

3.6 Troubleshoot Mode

In this mode, system status may be displayed on the 4-character display of the PRO-411. An internal voltmeter measures the voltage present at the channel/inputs, AC power input, and Notification Appliance Circuit. A lack of keyboard activity for a period of 20 minutes will cause the panel to return to Normal Mode.

To access the Troubleshoot Mode, press the **MODE** key followed by the digits 8768 and then the [ENTER/STORE] key.

8768 spells TROU on a Touch-Tone® phone.

Once in this mode, the 411UDAC will continue to communicate any events not yet acknowledged at a central station prior to entering Troubleshoot Mode. The **UP** arrow and **DOWN** arrow keys do not function in this mode.

All status displays in Troubleshoot Mode are shown in real-time, which means the display will update automatically as the status changes.

Channel/Inputs

Pressing **1** through **4** followed by the [ENTER/STORE] key on the PRO-411 displays the input status of the selected channel. Listed below are the status display and corresponding nominal threshold voltages, as measured across B+ and B-, for each zone:

Channel #	Normal with ELR	Shorted	Open Circuit
1 through 4 (status)	\sqcap	$\overline{\text{F}}$	F
1 and 3 (voltage)	11.5V	0V	12.0V
2 and 4 (voltage)	5.0V	0V	12.0V

Where \sqcap = normal, $\overline{\text{F}}$ = active, and F = fault (or open)

AC Line

Pressing **A** followed by the [ENTER/STORE] key will display the AC input voltage as shown below. The following lists the AC line voltage range. The AC Power LED will turn off and the trouble LED will turn on when the AC line voltage drops below the Low Line threshold.

AC Line Voltage	Low Line	Normal	High Line
	102 VAC	115 VAC	132 VAC

Notification Appliance Circuit

Pressing **8** followed by the [ENTER/STORE] key will display the status of the Notification Appliance Circuit. Listed below are the status display and corresponding nominal threshold voltages for the NAC measured across B+ and B-:

NAC	Normal with ELR	Shorted	Open Circuit
status	\sqcap	S	\square
voltage	-1.0V	0V	-5.5V

Where \sqcap = normal, S = shorted, and \square = open

Telephone Line Testing

Press **C** for touchtone dialing or **D** for rotary dialing, followed by **[ENTER/STORE]**.

The Programmer keypad may be used as a telephone touchpad for number dialing. Once the first digit is pressed, the display will move the **C** or **D** character one position to the left, while placing the next digit to be dialed on the farthest right display position. Continue to press the phone numbers to be dialed. The dialer stores the digits as they are pressed. Press **1st EVENT** to go off hook and dial the stored digits. Pressing **[ENTER/STORE]** after dialing has started will terminate dialing. Successive depressions of the **1st EVENT** key hangs up and picks up the phone (places the phone on or off the hook).

The secondary phone line may be tested by pressing the **E** key for touchtone dialing or the **F** key for rotary dialing and then following the same procedure used for the primary phone line. A handset may be temporarily connected across transformer T1 of the 411UDAC as indicated in Figure 3.1. The handset, when connected across T1, may be used only as an amplifier/speaker or telephone with the keypad used for number dialing.

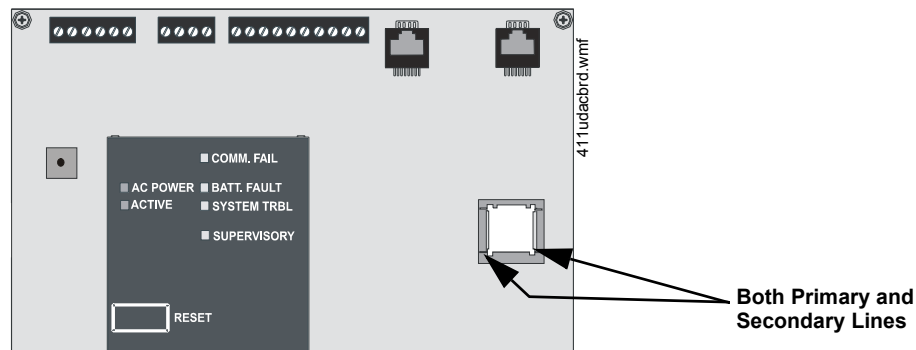

Figure 3.1 Handset/Speaker Connection

Section 4: Central Station Communications

The 411UDAC transmits system status reports to Central Stations via the public switched telephone network. Two supervised telephone line connections are made to interface the communicator to the telephone lines. Two 7-foot telephone cords P/N MCBL-7 may be used for this purpose (not supplied - order separately).

The digital communicator supervises both telephone lines for proper voltage. A delay of two minutes will occur before a fault in either phone line connection is reported as a trouble. When a fault is detected, an audible trouble signal will sound, the yellow Trouble LED will turn on, the optional trouble relay will activate if programmed for DACT trouble and the trouble condition will be reported to a central station over the remaining good phone line.

The digital communicator comes with line seizure capability provided for both the primary and secondary telephone line interfaces. Any time that the DACT needs to make a call to a central station, line seizure will disconnect any local premises phones sharing the same telephone line. All transmissions to central stations will be sent over the Primary Central Station phone line. In the event of noisy phone lines, transmissions will be sent over the backup Secondary phone line.

Two phone numbers must be programmed, the Primary Central Station phone number and the Secondary Central Station phone number. There are three options for transmission to the Central Station:

- All reports are always sent to the Primary Central Station phone number with the Secondary Central Station number for emergency backup purposes only
- All reports are sent to both Central Station phone numbers
- Reports are sent to the first available Central Station phone number only

The digital communicator is capable of reporting detailed messages depending upon the Format in use. Table 4.1 shows the data reporting structure for each of the pulsed formats as well as the Ademco Express Formats. Ademco Express Formats allow a typical data message to be transmitted to the Central Station in under 5 seconds. Pulsed formats typically require 15 to 20 seconds in comparison. Table 4.2 defines each letter code used in Table 4.1. See “Ademco Contact ID Format Event Code Description” on page 57 for a description of the data reporting structure for Ademco Contact ID Format.

	Format # 0, 2, 4, 6, 8	Format # 3, 5, 7, 9	Format # 1, A, C	Format # B, D
Report	3+1/4+1/Standard 4+1 Express	3+1/4+1/Expanded	4+2/Standard 4+2 Express	4+2/Expanded
Fire Alarm	SSS(S) FA	SSS(S) FA FAFAFA(FA) 2	SSSS FAFA2	SSSS FAZ
Fire Alarm Restore	SSS(S) RFA	SSS(S) RFA RFARFARFA (RFA) 2	SSSS RFARFA2	SSSS RFAZ
Channel/Input Trouble (Channel/Input Open)	SSS(S) TZ	SSS(S) TZ TZTZTZ(TZ) Z	SSSS TZTZ2	SSSS TZZ
Channel/Input Trouble Restore	SSS(S) RTZ	SSS(S) RTZ RTZRTZRTZ(RTZ) Z	SSSS RTZRTZ2	SSSS RTZZ
System Trouble	SSS(S) TS	SSS(S) TS TSTSTS(TS) Y	SSSS TSTS2	SSSS TSY
System Trouble Restore	SSS(S) RTS	SSS(S) RTS RTSRTSRTS(RTS) Y	SSSS RTSRTS2	SSSS RTSY
AC Loss	SSS(S) P	SSS(S) P PPP(P) Z	SSSS PP2	SSSS PP2
AC Loss Restore	SSS(S) RP	SSS(S) RP RPRPRP(RP) Z	SSSS RPRP2	SSSS RPRP2
Fire Supervisory Condition	SSS(S) V	SSS(S) V VVV(V) Z	SSSS VV2	SSSS VZ
Fire Supervisory Condition Restore	SSS(S) RV	SSS(S) RV RVRVR(RV) Z	SSSS RVRV2	SSSS RVZ
Test Report	SSS(S) X	SSS(S) X	SSSS XX2	SSSS XX2
Up or Download	SSS(S) UD	SSS(S) UD	SSS UDUD2	SSS UDUD2

Table 4.1 Format Selection Addresses (20 and 50) Programming

Where:

SSS or SSSS	=	Subscriber ID
FA	=	Fire Alarm (1st digit)
FA2	=	Fire Alarm (2nd digit)
Z	=	Channel/Input Number
RFA	=	Fire Alarm Restore (1st digit)
RFA2	=	Fire Alarm Restore (2nd digit)
TZ	=	Zone Trouble (1st digit)
TZ2	=	Zone Trouble (2nd digit)
RTZ	=	Zone Trouble Restore (1st digit)
RTZ2	=	Zone Trouble Restore (2nd digit)
TS	=	System Trouble (1st digit)
TS2	=	System Trouble (2nd digit)
RTS	=	System Trouble Restore (1st digit)
RTS2	=	System Trouble Restore (2nd digit)
P	=	AC Loss (1st digit)
P2	=	AC Loss (2nd digit)
RP	=	AC Loss Restore (1st digit)
RP2	=	AC Loss Restore (2nd digit)
V	=	Fire Supervisory Condition (1st digit)
V2	=	Fire Supervisory Condition (2nd digit)
RV	=	Fire Supervisory Condition Restore (1st digit)
RV2	=	Fire Supervisory Condition Restore (2nd digit)
X	=	Test Report (1st digit)
X2	=	Test Report (2nd digit)
Y	=	Trouble corresponding to the following:
	1	= Not Used
	2	= Not Used
	3	= Not Used
	4	= Telco Primary Line Fault
	5	= Telco Secondary Line Fault
	6	= Not Used
	7	= Not Used
	8	= Not Used
	9	= Not Used
	A	= Communication Failure Primary Number
	B	= Communication Failure Secondary Number
	C	= Not Used
	D	= Not Used
	E	= Not Used
	F	= Not Used
UD	=	Upload/Download (1st digit)
UD2	=	Upload/Download (2nd digit)

Table 4.2 Format Selection Address Explanation

Note that for Expanded Reporting, the digital communicator automatically adds the digit corresponding to the Channel/Input number, and the second digit corresponding to any system trouble condition. Only the first digit shown in Table 3.3 and Table 3.6 is programmable.

4.1 Transmittal Priorities

The digital communicator transmits highest priority events first. Events in terms of priority are listed below in descending order:

1. Fire Alarm (highest priority level)
2. Fire Supervisory
3. System Troubles
 - Host Panel Trouble (active input programmed for trouble)
 - AC Fail (after delay)
 - Channel/Input faults
 - Telephone line fault
 - Communication trouble
 - System Off Normal
4. Restoral Reports
 - Fire Alarm
 - Fire Supervisory
 - Host Panel Trouble
 - AC
 - Channel/Input fault
 - Telephone line
 - Communication
 - System Off Normal
5. System Test
6. Upload/Download events (lowest priority)

4.2 Ademco Contact ID Format Event Code Description

This section describes the various Event Codes and their messages which are available for the Ademco Contact ID Format. The reporting structure for the Ademco Contact ID Format is as follows:

SSSS 18 QXYZ GG CCC

Where:

SSSS	=	Four digit Subscriber ID Account Code (addresses 21 - 24 and 51 - 54)
18	=	Identifies transmission as Contact ID to the receiver at the Central Station
Q	=	Event Qualifier where 1 = New Event and 3 = New Restore
XYZ	=	Event code (shown in Tables)
GG	=	Group number
CCC	=	Channel/Input number

Notes:

1. **18**, which is used in the reporting structure to identify the transmission as Contact ID, is not printed out in the alarm and trouble report.
2. **Q**, which is the Event Qualifier for the reporting structure, is printed out in the report as an **E** for New Event or **R** for New Restore.
3. GG Group Number is fixed at '00' and cannot be changed.
4. CCC Channel/Input Number is transmitted as '001' for Channel/Input 1, '002' for Channel/Input 2, '003' for Channel/Input 3, '004' for Channel/Input 4.

Ademco Contact ID Reporting Structure

A typical printout from a Central Station receiver (such as the Ademco 685) of alarm and trouble reports in the Ademco Contact ID Reporting Structure follows:

<u>Time</u>	<u>Date</u>	<u>Rcvr/Line ID</u>	<u>SSSS</u>	<u>QXYZ</u>	<u>GG</u>	<u>CCCC</u>
11:28	03/25	11	7777	E110	00	C001 - general fire alarm on Channel/Input 1
11:28	03/25	11	7777	E111	00	C002 - smoke detector alarm on Channel/Input 2
11:28	03/25	11	7777	E380	00	C003 - fault on Channel/Input 3
11:28	03/25	11	7777	R110	00	C001 - Channel/Input 1 alarm restored
11:28	03/25	11	7777	R111	00	C002 - smoke detector Channel/Input 2 restored
11:28	03/25	11	7777	R380	00	C003 - Channel/Input 3 fault restored
11:28	03/25	11	7777	E158	00	C004 - high temperature, Channel/Input 4
11:28	03/25	11	7777	E151	00	C004 - gas detected, Channel/Input 4

The following table contains UL listed receivers compatible with the 411UDAC's onboard DACT.

Format # (Addresses 20 and 50)		FBI CP220FB (1)	Ademco 685 (2)	Silent Knight 9000 (3)	Silent Knight 9800 (4)	Osborne Hoffman 2000E (5)	Radionics 6600 (6)	Surgard System III (7)	Surgard MLR-2 (8)	Surgard MR-2000 (9)	Ademco MX8000 (10)
0	4+1 Ademco Express	✓	✓		✓	✓	✓	✓	✓	✓	✓
1	4+2 Ademco Express	✓	✓		✓	✓	✓	✓	✓	✓	✓
2	3+1/Standard/1800/2300	✓	✓	✓	✓	✓				✓	✓
3	3+1/Expanded/1800/2300	✓	✓	✓	✓	✓				✓	✓
4	3+1/Standard/1900/1400	✓	✓	✓	✓	✓				✓	✓
5	3+1/Expanded/1900/1400	✓	✓	✓	✓	✓				✓	✓
6	4+1/Standard/1800/2300		✓	✓	✓	✓		✓	✓	✓	✓
7	4+1/Expanded/1800/2300		✓	✓	✓	✓		✓	✓	✓	✓
8	4+1/Standard/1900/1400		✓	✓	✓	✓		✓	✓	✓	✓
9	4+1/Expanded/1900/1400		✓	✓	✓	✓		✓	✓	✓	✓
A	4+2/Standard/1800/2300	✓	✓	✓	✓	✓	✓	✓	✓	✓	✓
B	4+2/Expanded/1800/2300	✓	✓	✓	✓	✓	✓	✓	✓	✓	✓
C	4+2/Standard/1900/1400	✓	✓	✓	✓	✓	✓	✓	✓	✓	✓
D	4+2/Expanded/1900/1400	✓	✓	✓	✓	✓	✓	✓	✓	✓	✓
E	Ademco Contact ID	✓	✓		✓	✓	✓	✓	✓	✓	✓

Table 4.3 Compatible UL Listed Receivers

- (1) With version 3.9 software.
- (2) With 685-8 Line Card with Rev. 4.4d software.
- (3) With 9002 Line Card Rev. 9035 software or 9032 Line Card with 9326A software.
- (4) With 124077V2.00 Receiver and 126047 Line Card Rev. M.
- (5) With V.7301 Receiver S/W.
- (6) With 01.01.03 Receiver S/W and Line Card 01.01.03.
- (7) Surgard System III software version 1.6.
- (8) Surgard MLR-2 software version 1.86.
- (9) With DSP4016 and V1.6 Line Card.
- (10) With 124060V206B and 124063 Line Card Rev. B

IMPORTANT! It is the installer's responsibility to ensure that the Digital Alarm Communicator/Transmitter is compatible with the Central Station Receiver, utilized by the monitoring service, prior to installation. The Compatibility Table provides a list of compatible receivers and associated software versions for the receivers. Changes in the hardware and/or software by the receiver manufacturers may affect the receiver compatibility with the DACT. After completing the installation, communication between the DACT and Central Station Receiver must be tested and verified.

Section 5: Remote Site Upload/Download

The 411UDAC may be programmed off site via the public switched telephone network. Any personal computer with Windows® XP or greater Upload/Download software P/N PK-411UD (available on PK-CD or online), may serve as a Service Terminal. For details on the remote site upload/download software package, refer to the *PK-411UD Manual*. The Upload/Download software allows the following:

- Download of the entire program
- Upload of the entire program
- Upload current status, system voltages or time
- Real-time upload of current status or system voltages
- Download new time



CAUTION: ERROR CHECKING

CHANGES TO PROGRAM ENTRIES OCCUR AS A RESULT OF THE DOWNLOADING PROCESS. AFTER SUCCESSFUL DOWNLOADING, MAKE CERTAIN TO PERFORM THE FOLLOWING STEPS:

1. Manually view programmed entries and compare to intended program data.
 2. Test all affected system operations.
 3. Immediately correct any problems found.
-

5.1 General

Any time that the digital communicator is contacted, a secret code (factory default 0000) is verified between the digital communicator and the Service Terminal. Changing the Secret Code may only be accomplished at the Service Terminal and subsequently loaded into the panel. Future upload or download requests cause verification of the Secret Code by the communicator before processing of data is allowed. If the Secret Code is not verified, the communicator will terminate the request immediately.

In order to contact the communicator, the following must be true:

- ✓ The digital communicator may be in any mode of operation including Normal, Program, Real Time Clock, Troubleshoot or Lamp Test. Downloading is not possible if the communicator is active during Central Station communications or while testing the phone lines while in Troubleshoot Mode.
- ✓ The digital communicator must be unlocked so it can accept a remote upload/download. Entering mode **8655** (UNLK) will unlock the panel for 30 minutes. Refer to "Panel Unlock (90)" for other programming options.
- ✓ There cannot be any active communications ongoing with a Central Station receiver.
- ✓ All active events must be successfully 'kissed-off' by the Central Station(s). The digital communicator must be in a standby state with no new information waiting to be transmitted to a Central Station.

Two basic communication mechanisms are supported as follows:

- Contact with callback - The Service Terminal calls the digital communicator. The communicator answers the call, confirms the calling party then hangs-up. The Service Terminal then waits for a callback from the communicator. After the digital communicator calls the Central Station and successfully reports that a request has been received, the communicator calls the Service Terminal back. Upon secret code verification, data transfers occur. When the data transfers are completed and the Service Terminal disconnects from the communicator, the digital communicator calls the Central Station back to confirm either successful or unsuccessful results.

- Contact with callback disabled - The Service Terminal calls the communicator. No hang-up sequence occurs. Data transfers proceed.

Note that Callback enable/disable is controlled by the master user at the Service Terminal on a per call basis.

With program address location 64 set to '1' in Program Mode, anytime a contact with callback is initiated, the communicator will first either contact the primary Central Station or contact both the primary and secondary Central Stations or contact the first available Central Station phone number to report a 'request for upload/download' message (depending upon the program entry in address location 137). Once the request is 'kissed-off' by the Central Station(s), the communicator will then call the appropriate Service Terminal and begin the downloading process.

With program address location 64 set to '1' in Program Mode, anytime a contact with callback disabled is initiated, the communicator and the Service Terminal will communicate and transfer data without first contacting a Central Station. When the data transfers are completed and the communicator disconnects from the Service Terminal, the communicator will call the Central Station and report one of the following:

- Upload/download request received
- Upload and/or download successful
- Upload/download failed

To prevent the 'request for upload/download' message(s) from being reported to the Central Station(s), make certain to set address 64 to '0' or '3' or disable all upload/download reports back to both Central Stations. Refer to Table 3.2 on page 38 through Table 3.4, "Ademco Contact ID Format - Secondary," on page 42 for additional information.

Unlike most competitive products, during the downloading process, the input monitoring and 411UDAC supervision remain active. Should an input activation or system trouble occur, the communicator immediately terminates downloading, processes the trouble or alarm locally and transmits the information to the Central Station(s).

5.1.1 Security Features

Remote site upload and download with the 411UDAC have been carefully designed to include key security features to ensure proper functionality. The key features are listed and explained below.

Secret Code Verification

A secret code is stored in the communicator by a Service Terminal to prevent unauthorized access. The secret code is created at the Service Terminal by a Master user and cannot be viewed or changed by anyone other than a Master user. Viewing of the secret code is prohibited at the communicator. Prior to allowing an upload or download of data, the communicator will verify the secret code transmitted by the Service Terminal.

Panel Unlock

The communicator must be in an unlocked state to accept a remote upload/download. Entering the 4 digit code will unlock the panel for a period of 30 minutes, unless otherwise programmed.

Time-out at 411UDAC

Upon answering an incoming call on the primary Central Station phone line, the communicator will listen for a modem connection signal. If this signal is not received within 30 seconds, the communicator will disconnect the call. Upon successful connection (i.e. secret code verified and callback complete if applicable), if no communication occurs within two minutes, the communicator will disconnect the call.

Callback to Service Terminal

Any time that the communicator is remotely requested to allow an upload or download with callback, it will confirm the source of the incoming call, hang-up and call the calling party (Service Terminal phone number) back.

Error Checking

As each block of data is received by the communicator, it is checked for accuracy. If an error is detected, the block is retransmitted until correct, up to a maximum of four times. If the Secret Code is not verified and four errors occur, the call is disconnected and the report that the upload/download was not successful is called to the Central Station(s).

Central Station Acknowledge

There is an option whereby the communicator will report to one or both Central Stations that a request for uploading or downloading has been received prior to processing the call. This is called the 'callback' option. If the Central Station(s) does not acknowledge receipt of this request, uploading or downloading is prohibited. If acknowledged by the Central Station(s), another message is transmitted informing the Central Station(s) that:

- downloading was successful
- uploading was successful
- uploading/downloading was not successful

Data Protection/Integrity

Programming data is completely verified for accuracy prior to reprogramming of the 411UDAC EEPROM. Incomplete or corrupted data packets are ignored or retried.

5.2 Downloading to the Communicator

Before initiating the download procedure, make certain that the communicator is unlocked and in the standby state.

Once an incoming call is accepted/answered by the communicator, the 411UDAC will:

1. Establish basic modem connection
2. Verify secret code
3. Verify callback vs. no callback request from the Service Terminal. If callback is requested, perform steps 4 through 10; if no callback is requested, perform steps 9 and 10 only
4. Verify product type
5. Identify the Service Terminal location
6. Hang-up/disconnect call
7. Call the Central Station(s) and transmit a request for upload/download message (if programmed to do so). If this message is accepted, the communicator will proceed to the next step
8. Return call to the Service Terminal
9. Verify secret code
10. Verify Product type
11. Begin downloading
12. Upon completion of download, call the Central Station(s) back and report a successful download or failed upload/download status (if programmed to do so).

5.3 Uploading From the Communicator

Items that may be uploaded from the communicator to a Service Terminal are:

- All or portions of programmed data plus the real time clock

- Troubleshoot system voltages in real-time or as a 'snapshot'
- Current system status in real-time continuous or as a 'snapshot'

Uploading is possible at any time provided the following conditions are true:

- ✓ The communicator may be in any mode of operation. Uploading is not possible if the communicator is active or while testing the phone lines while in Troubleshoot Mode.
- ✓ There cannot be any active communications ongoing with a Central Station receiver.
- ✓ All active events must be successfully 'kissed-off' by the Central Station(s). The communicator must be in a standby state with no new information waiting to be transmitted to a Central Station.

Once an incoming call is accepted/answered by the communicator, the 411UDAC will:

1. Establish basic modem connection
2. Verify secret code
3. Verify callback vs. no callback request from the Service Terminal. If callback is requested, perform steps 4 through 10; if no callback is requested, perform steps 9 and 10 only
4. Verify product type
5. Identify the Service Terminal location
6. Hang-up/disconnect call
7. Call the Central Station(s) and transmit a request for upload/download message (if programmed to do so). If this message is accepted, the communicator will proceed to the next step
8. Return call to the Service Terminal
9. Verify secret code
10. Verify product type
11. Begin downloading
12. Upon completion of download, call the Central Station(s) back and report a successful download or failed upload/download status (if programmed to do so).

Unlike most competitive products, during the uploading process, the 411UDAC fire protection remains active. Should a system trouble or alarm condition occur, the communicator immediately terminates uploading and processes the trouble or alarm locally and transmits the information to the Central Station(s).

5.4 Simultaneous Data Transfers

Uploading and downloading may take place on a single telephone call. Control and selection of the data transaction is coordinated at the Service Terminal. This eliminates multiple phone calls, allows instant verification of downloaded data files and simplifies the overall process.

Section 6: Battery Calculations

Use the Total Standby and Alarm Load Currents calculated in Tables 6.2, and 6.3, for the following battery calculations.

Standby Load Current in amps (from Table 6.2)		X	Required Standby Time in Hours (24 or 60 Hours)		=	_____
[]			[]			
Alarm Load Current in amps (from Table 6.3)		X	Required Alarm Time in Hours (i.e. 5 min. = 0.084 Hours)		=	_____
[]			[]			
Add Standby and Alarm Load for Required Ampere Hour Battery						_____
Multiplying by derating factor of 1.2						X1.2
Total Ampere Hour Battery ¹						= _____

Table 6.1 Battery Calculations

1. Select a battery with an Amp Hour rating greater than that calculated in Table 6.1.
 - ✓ NFPA 72 for Central Station and Proprietary Protected Premises systems require 24 hours of standby
2. Two 12 VDC, 7 Amp Hour batteries, wired in parallel, can be located in the backbox to provide 14 Amp Hours of backup (refer to Figure 2.4 on page 22 for battery cable connections)

6.1 411UDAC Power Supply

The 411UDAC provides filtered power for operating the digital communicator, external devices and the battery charger. The power for operating external devices is limited. Use Table 6.2 (standby or nonalarm) and Table 6.3 (alarm) to determine if external loading is within the capabilities of the power supply.

Device Type	# of Devices		Current (amps)		Total Current (amps)
Main Circuit Board	1	X	0.125	=	0.125
4-wire Detector Heads	[]	X	[]	=	
Power Supervision Relays		X		=	
Additional Current Draw from 12 VDC Resettable	[]	X	[]	=	
Sum Column for Standby Load				=	amps

Table 6.2 Load in Standby

Notes:

1. Refer to the *Device Compatibility Document* for compatible listed power supervision relays.
2. Refer to the *Device Compatibility Document* for 4-wire smoke detector standby current.

Device Type	# of Devices		Current (amps)		Total Current (amps)
Main Circuit Board	1	X	0.180	=	0.180
4-wire Detector Heads	[]	X	[]	=	
Power Supervision Relay	[]	X	0.025	=	
Notification Appliances	[]	X	[]	=	
Additional Current Draw from 12 VDC Resettable	[]	X	[]	=	
Sum Column for Alarm Load				=	amps

Table 6.3 Load in Alarm

Notes:

1. Refer to the *Device Compatibility Document* for compatible listed power supervision relays.
2. Refer to the *Device Compatibility Document* for 4-wire smoke detector current.
3. Maximum available current for notification appliances is 1.0 amp
4. Maximum available current from resettable output is 0.200 amps
5. Total system current cannot exceed 1.6 amps

Appendix A: Programming Sheets

A.1 Digital Communicator Options Program Sheets

To enter Programming Mode, press the **MODE** key, **7764**, and then the **[ENTER/STORE]** key.

00 01 02 03 04 05 06 07 08 09 10 11 12 13 14 15 16 17 18 19

Addresses 00 to 19 store the Primary Central Station phone number. *Enter 'F' to represent the end of number.*

20 Primary Central Station Communication Format: *Valid entries are 0 to 9 and A to F.*

21 22 23 24 Primary Central Station Account Code: *Valid entries are 0 to 9 and A to F.*

25 26 27 28 Primary Central Station 24-hour Test Time: *Use military time (i.e. 1400 for 2:00 PM).*

29 Primary Number Test Time Interval. Enter '0' for 24-hour; '1' for 12-hour; '2' for 8-hour; '3' for 6-hour.

30 31 32 33 34 35 36 37 38 39 40 41 42 43 44 45 46 47 48 49

Addresses 30 to 49 store the Secondary Central Station phone number. *Enter 'F' to represent the end of number.*

50 Secondary Central Station Communication Format: *Valid entries are 0 to 9 and A to F.*

51 52 53 54 Secondary Central Station Account Code: *Valid entries are 0 - 9 and A - F.*

55 56 57 58 Secondary Central Station 24-hour Test Time: *Use military time (i.e. 1400 for 2:00 PM).*

59 Secondary Number Test Time Interval. Enter '0' for 24-hour; '1' for 12-hour; '2' for 8-hour; '3' for 6-hour.

60 AC Loss Reporting Delay. Enter '0' for no delay; '1' for 1 hours; '2' for 2 hours; '3' for 6 hours; '4' for 7 hours; '5' for 8 hours; '6' for 9 hours; '7' for 10 hours; '8' for 11 hours; '9' for 12 hours; 'A' for 13 hours; 'B' for 14 hours; 'C' for 15 hours; 'D' for 16 hours; 'E' for 17 hours; 'F' for 18 hours.

61 Backup Reporting. Enter '0' to report to Secondary phone number as backup only; '1' to report to both Primary and Secondary phone number for all reports/messages; '2' reports go to first available receiver.

62 Reserved for Future Use.

63 DACT Trouble Reminder. Enter '0' to disable; '1' to enable.

64 Operational Mode Selection. *Enter '0' for stand-alone/communicator disabled; '1' for stand-alone/communicator enabled; '2' for slave/communicator enabled; '3' for slave/communicator disabled. Default setting is '0'.*

65 Input Channel 1 Function Selection. Enter '0' for fire alarm; '1' for pull station; '2' for normally open contact; '3' for host panel trouble; '4' for supervisory; '5' for supervisory autoresettable; '6' for waterflow silenceable; '7' for waterflow nonsilenceable.

66 Input Channel 2 Function Selection. Enter '1' for pull station; '2' for normally open contact; '3' for host panel trouble; '4' for supervisory; '5' for supervisory autoresettable; '6' for waterflow silenceable; '7' for waterflow nonsilenceable.

67 Input Channel 3 Function Selection. Enter '0' for fire alarm; '1' for pull station; '2' for normally open contact; '3' for host panel trouble; '4' for supervisory; '5' for supervisory autoresettable; '6' for waterflow silenceable; '7' for waterflow nonsilenceable.

68 Input Channel 4 Function Selection. Enter '1' for pull station; '2' for normally open contact; '3' for host panel trouble; '4' for supervisory; '5' for supervisory autoresettable; '6' for waterflow silenceable; '7' for waterflow nonsilenceable.

69 70 71 Input Channel 1 Delay Timer. Enter 0 - 179 seconds delay. *Factory default is '000' for no delay. Does not delay Input Channels programmed for fire functions.*

72 73 74 Input Channel 2 Delay Timer. Enter 0 - 179 seconds delay. *Factory default is '000' for no delay. Does not delay Input Channels programmed for fire functions.*

75 76 77 Input Channel 3 Delay Timer. Enter 0 - 179 seconds delay. *Factory default is '000' for no delay. Does not delay Input Channels programmed for fire functions.*

- ₇₈ ₇₉ ₈₀ Input Channel 4 Delay Timer. Enter 0 - 179 seconds delay. *Factory default is '000' for no delay. Does not delay Input Channels programmed for fire functions.*
- ₈₁ Touchtone/Rotary Select for Primary Phone. Enter '0' for touchtone dialing; '1' for rotary dialing.
- ₈₂ Make/Break Ratio for Primary Phone. Enter '0' for 67/33 ratio; '1' for 62/38 ratio.
- ₈₃ Touchtone/Rotary Select for Secondary Phone. Enter '0' for touchtone dialing; '1' for rotary dialing.
- ₈₄ Make/Break Ratio for Secondary Phone. Enter '0' for 67/33 ratio; '1' for 62/38 ratio.
- ₈₅ Output Relay #1 enable. Enter '1' to enable Relay #1; '0' to disable relay.
- ₈₆ Output Relay #1 Function. Enter '0' for relay to activate on alarm; '1' host panel trouble; '2' DACT trouble; '3' for latching fire supervisory; '4' for autoresettable fire supervisory; '7' (future use); '8' for total communication failure.
- ₈₇ Output Relay #2 enable. Enter '1' to enable Relay #2; '0' to disable relay.
- ₈₈ Output Relay #2 Function. Enter '0' for relay to activate on fire alarm; '1' host panel trouble; '2' for DACT trouble; '3' for latching fire supervisory; '4' for autoresettable fire supervisory; '7' (future use); '8' total communication failure.
- ₈₉ Reserved for future use. Leave default setting of '0.'
- ₉₀ Panel unlock. Enter '0' for password unlock, '1' for permanent unlock.
- ₉₁ Alarm verification. Enter '0' for no verification; '1' for verification of all 4-wire smoke zones.
- ₉₂ Silence inhibit. Enter '0' for no silence inhibit; '1' to inhibit silencing of NAC for one minute.
- ₉₃ Autosilence. Enter '0' for no autosilence; '1' for 5 minute autosilence; '2' for 10 minutes; '3' for 15 minutes; '4' for 20 minutes; '5' for 25 minutes; '6' for 30 minutes.
- ₉₄ Restoral method. Enter '0' for Typical restoral method; '1' for Conditional Restoral Method #1; '2' for Conditional Restoral Method #2.
- ₉₅ Coding, Notification Appliance Circuit. Enter '0' for no coding (steady); '1' for Temporal coding.
- ₉₆ Trouble Call Limit - Dialer Runaway Prevention Feature. Enter a '0' to disable this feature; '1' to enable Trouble Call Limit. *Factory default is '0' for disabled.*
- ₉₇ ₉₈ ₉₉ ₁₀₀ Panel Identification Number.
- ₁₀₁ ₁₀₂ ₁₀₃ ₁₀₄ ₁₀₅ ₁₀₆ ₁₀₇ ₁₀₈ ₁₀₉ ₁₁₀ ₁₁₁ ₁₁₂ ₁₁₃ ₁₁₄ ₁₁₅ ₁₁₆ ₁₁₇ ₁₁₈
- ₁₁₉ ₁₂₀ Addresses 101 to 120 store the Service Terminal 1 Phone Number. *Valid entries are 0 - 9 and A - E. 'F' designates the end of the phone number.*
- ₁₂₁ ₁₂₂ Ring Count on Primary Phone Line. Enter number of rings prior to panel answering call. *Valid entries are 00 to 25 (00 = no answer). Factory default is 03.*
- ₁₂₃ FAX/Answer Machine, Primary Phone Line. Enter '0' for no sharing of phone line; '1' for sharing.
- ₁₂₄ ₁₂₅ ₁₂₆ ₁₂₇ ₁₂₈ ₁₂₉ ₁₃₀ ₁₃₁ ₁₃₂ ₁₃₃ ₁₃₄ ₁₃₅ ₁₃₆ ₁₃₇ ₁₃₈ ₁₃₉ ₁₄₀ ₁₄₁
- ₁₄₂ ₁₄₃ Addresses 124 to 143 store the Service Terminal 2 Phone Number. *Valid entries are 0-9 and A-E. 'F' designates the end of the phone number.*
- ₁₄₄ Upload/Download Backup Reporting. Enter '0' for Upload/Download reports to go to the Secondary Central Station Phone Number on backup only; '1' for Upload/Download reports to always go to the Secondary; '2' for Upload/Download reports to go to the first available Central Station phone number.

A.2 Digital Communicator Options Program Sheet (Factory Defaults)

To enter Programming Mode, press the **MODE** key, **7764**, and then the **[ENTER/STORE]** key.

₀₀ ₀₁ ₀₂ ₀₃ ₀₄ ₀₅ ₀₆ ₀₇ ₀₈ ₀₉ ₁₀ ₁₁ ₁₂ ₁₃ ₁₄ ₁₅ ₁₆ ₁₇ ₁₈ ₁₉

Addresses 00 to 19 store the Primary Central Station phone number. *Enter 'F' to represent the end of number.*

₂₀ Primary Central Station Communication Format: *'E' for Ademco Contact ID Format.*

₂₁ ₂₂ ₂₃ ₂₄ Primary Central Station Account Code.

₂₅ ₂₆ ₂₇ ₂₈ Primary Central Station 24-hour Test Time: *'0000' = 12:00 midnight.*

₂₉ Primary Number Test Time Interval. *'0' for 24-hours.*

₃₀ ₃₁ ₃₂ ₃₃ ₃₄ ₃₅ ₃₆ ₃₇ ₃₈ ₃₉ ₄₀ ₄₁ ₄₂ ₄₃ ₄₄ ₄₅ ₄₆ ₄₇ ₄₈ ₄₉

Addresses 30 to 49 store the Secondary Central Station phone number. *Enter 'F' to represent the end of number.*

₅₀ Secondary Central Station Communication Format: *'E' for Ademco Contact ID Format..*

₅₁ ₅₂ ₅₃ ₅₄ Secondary Central Station Account Code:

₅₅ ₅₆ ₅₇ ₅₈ Secondary Central Station 24-hour Test Time: *'0000' = 12:00 midnight.*

₅₉ Secondary Number Test Time Interval. *'0' for 24-hours.*

₆₀ AC Loss Reporting Delay. *'2' for 2 hour delay.*

₆₁ Backup Reporting. *'0' to report to Secondary phone number as backup only.*

₆₂ Reserved for Future Use.

₆₃ DACT Trouble Reminder. *'0' disables trouble reminder.*

₆₄ Operational Mode Selection. *'0' enables stand-alone mode, disables communication to Central Station.*

₆₅ Input Channel 1 Function Selection. *'0' for fire alarm.*

₆₆ Input Channel 2 Function Selection. *'1' for pull station alarm.*

₆₇ Input Channel 3 Function Selection. *'0' for fire alarm.*

₆₈ Input Channel 4 Function Selection. *'1' for pull station alarm.*

₆₉ ₇₀ ₇₁ Input Channel 1 Delay Timer. *'000' for no delay. Does not delay fire functions.*

₇₂ ₇₃ ₇₄ Input Channel 2 Delay Timer. *'000' for no delay. Does not delay fire functions.*

₇₅ ₇₆ ₇₇ Input Channel 3 Delay Timer. *'000' for no delay. Does not delay fire functions.*

₇₈ ₇₉ ₈₀ Input Channel 4 Delay Timer. *'000' for no delay. Does not delay fire functions.*

₈₁ Touchtone/Rotary Select for Primary Phone. *'0' for touchtone dialing.*

₈₂ Make/Break Ratio for Primary Phone. *'0' for 67/33 ratio.*

₈₃ Touchtone/Rotary Select for Secondary Phone. *'0' for touchtone dialing.*

₈₄ Make/Break Ratio for Secondary Phone. *'0' for 67/33 ratio.*

₈₅ Output Relay #1 enable. *'0' to disable relay.*

₈₆ Output Relay #1 Function. *'0' for activation on fire alarm (4-wire smoke).*

₈₇ Output Relay #2 enable. *'0' to disable relay.*

₈₈ Output Relay #2 Function. *'2' for activation on DACT trouble.*

- ₈₉ Reserved for future use. *Leave default setting of '0.'*
- ₉₀ Panel unlock. *'0' for password unlock.*
- ₉₁ Alarm verification. *'0' to disable.*
- ₉₂ Silence inhibit. *'0' to disable.*
- ₉₃ Autosilence. *'0' to disable.*
- ₉₄ Restoral method. *'0' for Typical restoral method.*
- ₉₅ Coding, Notification Appliance Circuit. *'0' for no coding (steady).*
- ₉₆ Trouble Call Limit - Dialer Runaway Prevention Feature. *'0' for disabled feature.*
- ₉₇ ₉₈ ₉₉ ₁₀₀ Panel Identification Number.
- ₁₀₁ ₁₀₂ ₁₀₃ ₁₀₄ ₁₀₅ ₁₀₆ ₁₀₇ ₁₀₈ ₁₀₉ ₁₁₀ ₁₁₁ ₁₁₂ ₁₁₃ ₁₁₄ ₁₁₅ ₁₁₆ ₁₁₇ ₁₁₈
- ₁₁₉ ₁₂₀ Addresses 101 to 120 store the Service Terminal 1 Phone Number. *Enter 'F' to represent the end of the phone number.*
- ₁₂₁ ₁₂₂ Ring Count on Primary Phone Line. *'03' for number of rings before answering call.*
- ₁₂₃ FAX/Answer Machine, Primary Phone Line. *'0' for no sharing of phone line.*
- ₁₂₄ ₁₂₅ ₁₂₆ ₁₂₇ ₁₂₈ ₁₂₉ ₁₃₀ ₁₃₁ ₁₃₂ ₁₃₃ ₁₃₄ ₁₃₅ ₁₃₆ ₁₃₇ ₁₃₈ ₁₃₉ ₁₄₀ ₁₄₁
- ₁₄₂ ₁₄₃ Addresses 124 to 143 store the Service Terminal 2 Phone Number. *Enter 'F' to represent the end of the phone number.*
- ₁₄₄ Upload/Download Backup Reporting. *'0' for Upload/Download reports to go to the Secondary Central Station Phone Number on backup only.*

Appendix B: Event Codes/Transmission Format Programming Sheets

To enter Programming Mode, press the **MODE** key, **7764** and then the **[ENTER/STORE]** key.

B.1 4+2 Standard & 4+2 Express Formats Primary Central Station

<input type="checkbox"/>	<input type="checkbox"/>	<input type="checkbox"/>	<input type="checkbox"/>	<input type="checkbox"/>	<input type="checkbox"/>	<input type="checkbox"/>	<input type="checkbox"/>	<input type="checkbox"/>	<input type="checkbox"/>	<input type="checkbox"/>	<input type="checkbox"/>	<input type="checkbox"/>	<input type="checkbox"/>	<input type="checkbox"/>	<input type="checkbox"/>
145	146	147	148	149	150	151	152	153	154	155	156	157	158	159	160
<input type="checkbox"/>	<input type="checkbox"/>	<input type="checkbox"/>	<input type="checkbox"/>	<input type="checkbox"/>	<input type="checkbox"/>	<input type="checkbox"/>	<input type="checkbox"/>	<input type="checkbox"/>	<input type="checkbox"/>	<input type="checkbox"/>	<input type="checkbox"/>	<input type="checkbox"/>	<input type="checkbox"/>	<input type="checkbox"/>	<input type="checkbox"/>
161	162	163	164	165	166	167	168	169	170	171	172	173	174	175	176
<input type="checkbox"/>	<input type="checkbox"/>	<input type="checkbox"/>	<input type="checkbox"/>	<input type="checkbox"/>	<input type="checkbox"/>	<input type="checkbox"/>	<input type="checkbox"/>	<input type="checkbox"/>	<input type="checkbox"/>	<input type="checkbox"/>	<input type="checkbox"/>	<input type="checkbox"/>	<input type="checkbox"/>	<input type="checkbox"/>	<input type="checkbox"/>
177	178	179	180	181	182	183	184	185	186	187	188	189	190	191	192
<input type="checkbox"/>	<input type="checkbox"/>	<input type="checkbox"/>	<input type="checkbox"/>	<input type="checkbox"/>	<input type="checkbox"/>	<input type="checkbox"/>	<input type="checkbox"/>	<input type="checkbox"/>	<input type="checkbox"/>	<input type="checkbox"/>	<input type="checkbox"/>	<input type="checkbox"/>	<input type="checkbox"/>	<input type="checkbox"/>	<input type="checkbox"/>
193	194	195	196	197	198	199	200	201	202	203	204	205	206	207	208
<input type="checkbox"/>	<input type="checkbox"/>	<input type="checkbox"/>	<input type="checkbox"/>	<input type="checkbox"/>	<input type="checkbox"/>	<input type="checkbox"/>	<input type="checkbox"/>	<input type="checkbox"/>	<input type="checkbox"/>	<input type="checkbox"/>	<input type="checkbox"/>	<input type="checkbox"/>	<input type="checkbox"/>	<input type="checkbox"/>	<input type="checkbox"/>
209	210	211	212	213	214	215	216	217	218	219	220	221	222	223	224
<input type="checkbox"/>	<input type="checkbox"/>	<input type="checkbox"/>	<input type="checkbox"/>	<input type="checkbox"/>	<input type="checkbox"/>	<input type="checkbox"/>	<input type="checkbox"/>	<input type="checkbox"/>	<input type="checkbox"/>	<input type="checkbox"/>	<input type="checkbox"/>	<input type="checkbox"/>	<input type="checkbox"/>	<input type="checkbox"/>	<input type="checkbox"/>
225	226	227	228	229	230	231	232								

B.2 4+2 Standard & 4+2 Express Formats Secondary Central Station

<input type="checkbox"/>	<input type="checkbox"/>	<input type="checkbox"/>	<input type="checkbox"/>	<input type="checkbox"/>	<input type="checkbox"/>	<input type="checkbox"/>	<input type="checkbox"/>	<input type="checkbox"/>	<input type="checkbox"/>	<input type="checkbox"/>	<input type="checkbox"/>	<input type="checkbox"/>	<input type="checkbox"/>	<input type="checkbox"/>	<input type="checkbox"/>
233	234	235	236	237	238	239	240	241	242	243	244	245	246	247	248
<input type="checkbox"/>	<input type="checkbox"/>	<input type="checkbox"/>	<input type="checkbox"/>	<input type="checkbox"/>	<input type="checkbox"/>	<input type="checkbox"/>	<input type="checkbox"/>	<input type="checkbox"/>	<input type="checkbox"/>	<input type="checkbox"/>	<input type="checkbox"/>	<input type="checkbox"/>	<input type="checkbox"/>	<input type="checkbox"/>	<input type="checkbox"/>
249	250	251	252	253	254	255	256	257	258	259	260	261	262	263	264
<input type="checkbox"/>	<input type="checkbox"/>	<input type="checkbox"/>	<input type="checkbox"/>	<input type="checkbox"/>	<input type="checkbox"/>	<input type="checkbox"/>	<input type="checkbox"/>	<input type="checkbox"/>	<input type="checkbox"/>	<input type="checkbox"/>	<input type="checkbox"/>	<input type="checkbox"/>	<input type="checkbox"/>	<input type="checkbox"/>	<input type="checkbox"/>
265	266	267	268	269	270	271	272	273	274	275	276	277	278	279	280
<input type="checkbox"/>	<input type="checkbox"/>	<input type="checkbox"/>	<input type="checkbox"/>	<input type="checkbox"/>	<input type="checkbox"/>	<input type="checkbox"/>	<input type="checkbox"/>	<input type="checkbox"/>	<input type="checkbox"/>	<input type="checkbox"/>	<input type="checkbox"/>	<input type="checkbox"/>	<input type="checkbox"/>	<input type="checkbox"/>	<input type="checkbox"/>
281	282	283	284	285	286	287	288	289	290	291	292	293	294	295	296
<input type="checkbox"/>	<input type="checkbox"/>	<input type="checkbox"/>	<input type="checkbox"/>	<input type="checkbox"/>	<input type="checkbox"/>	<input type="checkbox"/>	<input type="checkbox"/>	<input type="checkbox"/>	<input type="checkbox"/>	<input type="checkbox"/>	<input type="checkbox"/>	<input type="checkbox"/>	<input type="checkbox"/>	<input type="checkbox"/>	<input type="checkbox"/>
297	298	299	300	301	302	303	304	305	306	307	308	309	310	311	312
<input type="checkbox"/>	<input type="checkbox"/>	<input type="checkbox"/>	<input type="checkbox"/>	<input type="checkbox"/>	<input type="checkbox"/>	<input type="checkbox"/>	<input type="checkbox"/>	<input type="checkbox"/>	<input type="checkbox"/>	<input type="checkbox"/>	<input type="checkbox"/>	<input type="checkbox"/>	<input type="checkbox"/>	<input type="checkbox"/>	<input type="checkbox"/>
313	314	315	316	317	318	319	320								

--To enter Programming Mode, press the **MODE** key, **7764** and then the **[ENTER/STORE]** key.

B.3 4+2 Standard & 4+2 Express Formats Primary Central Station

1₁₄₅ **1**₁₄₆ **1**₁₄₇ **2**₁₄₈ **1**₁₄₉ **3**₁₅₀ **1**₁₅₁ **4**₁₅₂ **F**₁₅₃ **1**₁₅₄ **F**₁₅₅ **2**₁₅₆ **F**₁₅₇ **3**₁₅₈ **F**₁₅₉ **4**₁₆₀
9₁₆₁ **2**₁₆₂ **6**₁₆₃ **1**₁₆₄ **6**₁₆₅ **2**₁₆₆ **6**₁₆₇ **3**₁₆₈ **6**₁₆₉ **4**₁₇₀ **6**₁₇₁ **5**₁₇₂ **6**₁₇₃ **6**₁₇₄ **4**₁₇₅ **7**₁₇₆
6₁₇₇ **A**₁₇₈ **6**₁₇₉ **B**₁₈₀ **6**₁₈₁ **F**₁₈₂ **E**₁₈₃ **1**₁₈₄ **E**₁₈₅ **2**₁₈₆ **E**₁₈₇ **3**₁₈₈ **E**₁₈₉ **4**₁₉₀ **D**₁₉₁ **1**₁₉₂
D₁₉₃ **2**₁₉₄ **D**₁₉₅ **3**₁₉₆ **D**₁₉₇ **4**₁₉₈ **9**₁₉₉ **3**₂₀₀ **A**₂₀₁ **1**₂₀₂ **A**₂₀₃ **2**₂₀₄ **A**₂₀₅ **3**₂₀₆ **A**₂₀₇ **4**₂₀₈
A₂₀₉ **5**₂₁₀ **A**₂₁₁ **6**₂₁₂ **5**₂₁₃ **7**₂₁₄ **A**₂₁₅ **A**₂₁₆ **A**₂₁₇ **B**₂₁₈ **A**₂₁₉ **F**₂₂₀ **9**₂₂₁ **9**₂₂₂ **9**₂₂₃ **1**₂₂₄
7₂₂₅ **1**₂₂₆ **7**₂₂₇ **2**₂₂₈ **7**₂₂₉ **3**₂₃₀ **7**₂₃₁ **4**₂₃₂

B.4 4+2 Standard & 4+2 Express Formats Secondary Central Station

1₂₃₃ **1**₂₃₄ **1**₂₃₅ **2**₂₃₆ **1**₂₃₇ **3**₂₃₈ **1**₂₃₉ **4**₂₄₀ **F**₂₄₁ **1**₂₄₂ **F**₂₄₃ **2**₂₄₄ **F**₂₄₅ **3**₂₄₆ **F**₂₄₇ **4**₂₄₈
9₂₄₉ **2**₂₅₀ **6**₂₅₁ **1**₂₅₂ **6**₂₅₃ **2**₂₅₄ **6**₂₅₅ **3**₂₅₆ **6**₂₅₇ **4**₂₅₈ **6**₂₅₉ **5**₂₆₀ **6**₂₆₁ **6**₂₆₂ **4**₂₆₃ **7**₂₆₄
6₂₆₅ **A**₂₆₆ **6**₂₆₇ **B**₂₆₈ **6**₂₆₉ **F**₂₇₀ **E**₂₇₁ **1**₂₇₂ **E**₂₇₃ **2**₂₇₄ **E**₂₇₅ **3**₂₇₆ **E**₂₇₇ **4**₂₇₈ **D**₂₇₉ **1**₂₈₀
D₂₈₁ **2**₂₈₂ **D**₂₈₃ **3**₂₈₄ **D**₂₈₅ **4**₂₈₆ **9**₂₈₇ **3**₂₈₈ **A**₂₈₉ **1**₂₉₀ **A**₂₉₁ **2**₂₉₂ **A**₂₉₃ **3**₂₉₄ **A**₂₉₅ **4**₂₉₆
A₂₉₇ **5**₂₉₈ **A**₂₉₉ **6**₃₀₀ **5**₃₀₁ **7**₃₀₂ **A**₃₀₃ **A**₃₀₄ **A**₃₀₅ **B**₃₀₆ **A**₃₀₇ **F**₃₀₈ **9**₃₀₉ **9**₃₁₀ **9**₃₁₁ **1**₃₁₂
7₃₁₃ **1**₃₁₄ **7**₃₁₅ **2**₃₁₆ **7**₃₁₇ **3**₃₁₈ **7**₃₁₉ **4**₃₂₀

To enter Programming Mode, press the **MODE** key, **7764** and then the **[ENTER/STORE]** key.

B.5 All 3+1, All 4+1 and 4+2 Expanded Formats for Primary Central Station

₁₄₅ ₁₄₆ ₁₄₇ ₁₄₈ ₁₄₉ ₁₅₀ ₁₅₁ ₁₅₂ ₁₅₃ ₁₅₄ ₁₅₅ ₁₅₆ ₁₅₇ ₁₅₈ ₁₅₉ ₁₆₀
₁₆₁ ₁₆₂ ₁₆₃ ₁₆₄ ₁₆₅ ₁₆₆ ₁₆₇ ₁₆₈ ₁₆₉ ₁₇₀ ₁₇₁ ₁₇₂ ₁₇₃ ₁₇₄ ₁₇₅ ₁₇₆
₁₇₇ ₁₇₈ ₁₇₉ ₁₈₀ ₁₈₁ ₁₈₂ ₁₈₃ ₁₈₄ ₁₈₅ ₁₈₆ ₁₈₇ ₁₈₈

B.6 All 3+1, All 4+1 and 4+2 Expanded Formats for Secondary Central Station

₂₃₃ ₂₃₄ ₂₃₅ ₂₃₆ ₂₃₇ ₂₃₈ ₂₃₉ ₂₄₀ ₂₄₁ ₂₄₂ ₂₄₃ ₂₄₄ ₂₄₅ ₂₄₆ ₂₄₇ ₂₄₈
₂₄₉ ₂₅₀ ₂₅₁ ₂₅₂ ₂₅₃ ₂₅₄ ₂₅₅ ₂₅₆ ₂₅₇ ₂₅₈ ₂₅₉ ₂₆₀ ₂₆₁ ₂₆₂ ₂₆₃ ₂₆₄
₂₆₅ ₂₆₆ ₂₆₇ ₂₆₈ ₂₆₉ ₂₇₀ ₂₇₁ ₂₇₂ ₂₇₃ ₂₇₄ ₂₇₅ ₂₇₆

B.7 All 3+1, All 4+1 and 4+2 Expanded Formats for Primary Central Station (Factory Defaults)

₁₄₅ ₁₄₆ ₁₄₇ ₁₄₈ ₁₄₉ ₁₅₀ ₁₅₁ ₁₅₂ ₁₅₃ ₁₅₄ ₁₅₅ ₁₅₆ ₁₅₇ ₁₅₈ ₁₅₉ ₁₆₀
₁₆₁ ₁₆₂ ₁₆₃ ₁₆₄ ₁₆₅ ₁₆₆ ₁₆₇ ₁₆₈ ₁₆₉ ₁₇₀ ₁₇₁ ₁₇₂ ₁₇₃ ₁₇₄ ₁₇₅ ₁₇₆
₁₇₇ ₁₇₈ ₁₇₉ ₁₈₀ ₁₈₁ ₁₈₂ ₁₈₃ ₁₈₄ ₁₈₅ ₁₈₆ ₁₈₇ ₁₈₈

B.8 All 3+1, All 4+1 and 4+2 Expanded Formats for Secondary Central Station (Factory Defaults)

₂₃₃ ₂₃₄ ₂₃₅ ₂₃₆ ₂₃₇ ₂₃₈ ₂₃₉ ₂₄₀ ₂₄₁ ₂₄₂ ₂₄₃ ₂₄₄ ₂₄₅ ₂₄₆ ₂₄₇ ₂₄₈
₂₄₉ ₂₅₀ ₂₅₁ ₂₅₂ ₂₅₃ ₂₅₄ ₂₅₅ ₂₅₆ ₂₅₇ ₂₅₈ ₂₅₉ ₂₆₀ ₂₆₁ ₂₆₂ ₂₆₃ ₂₆₄
₂₆₅ ₂₆₆ ₂₆₇ ₂₆₈ ₂₆₉ ₂₇₀ ₂₇₁ ₂₇₂ ₂₇₃ ₂₇₄ ₂₇₅ ₂₇₆

--To enter Programming Mode, press the **MODE** key, **7764** and then the **[ENTER/STORE]** key.

B.9 Ademco Contact ID Format Primary Central Station

<input type="checkbox"/>	<input type="checkbox"/>	<input type="checkbox"/>	<input type="checkbox"/>	<input type="checkbox"/>	<input type="checkbox"/>	<input type="checkbox"/>	<input type="checkbox"/>	<input type="checkbox"/>	<input type="checkbox"/>	<input type="checkbox"/>	<input type="checkbox"/>	<input type="checkbox"/>	<input type="checkbox"/>	<input type="checkbox"/>	<input type="checkbox"/>
145	146	147	148	149	150	151	152	153	154	155	156	157	158	159	160
<input type="checkbox"/>	<input type="checkbox"/>	<input type="checkbox"/>	<input type="checkbox"/>	<input type="checkbox"/>	<input type="checkbox"/>	<input type="checkbox"/>	<input type="checkbox"/>	<input type="checkbox"/>	<input type="checkbox"/>	<input type="checkbox"/>	<input type="checkbox"/>	<input type="checkbox"/>	<input type="checkbox"/>	<input type="checkbox"/>	<input type="checkbox"/>
161	162	163	164	165	166	167	168	169	170	171	172	173	174	175	176
<input type="checkbox"/>	<input type="checkbox"/>	<input type="checkbox"/>	<input type="checkbox"/>	<input type="checkbox"/>	<input type="checkbox"/>	<input type="checkbox"/>	<input type="checkbox"/>	<input type="checkbox"/>	<input type="checkbox"/>	<input type="checkbox"/>	<input type="checkbox"/>	<input type="checkbox"/>	<input type="checkbox"/>	<input type="checkbox"/>	<input type="checkbox"/>
177	178	179	180	181	182	183	184	185	186	187	188	189	190	191	192
<input type="checkbox"/>	<input type="checkbox"/>	<input type="checkbox"/>	<input type="checkbox"/>	<input type="checkbox"/>	<input type="checkbox"/>	<input type="checkbox"/>	<input type="checkbox"/>	<input type="checkbox"/>	<input type="checkbox"/>	<input type="checkbox"/>	<input type="checkbox"/>	<input type="checkbox"/>	<input type="checkbox"/>	<input type="checkbox"/>	<input type="checkbox"/>
193	194	195	196	197	198	199	200	201	202	203	204	205	206	207	208
<input type="checkbox"/>	<input type="checkbox"/>	<input type="checkbox"/>	<input type="checkbox"/>	<input type="checkbox"/>	<input type="checkbox"/>	<input type="checkbox"/>	<input type="checkbox"/>	<input type="checkbox"/>	<input type="checkbox"/>	<input type="checkbox"/>	<input type="checkbox"/>	<input type="checkbox"/>	<input type="checkbox"/>	<input type="checkbox"/>	<input type="checkbox"/>
209	210	211	212	213	214	215	216	217	218	219					

B.10 Ademco Contact ID Format Secondary Central Station

<input type="checkbox"/>	<input type="checkbox"/>	<input type="checkbox"/>	<input type="checkbox"/>	<input type="checkbox"/>	<input type="checkbox"/>	<input type="checkbox"/>	<input type="checkbox"/>	<input type="checkbox"/>	<input type="checkbox"/>	<input type="checkbox"/>	<input type="checkbox"/>	<input type="checkbox"/>	<input type="checkbox"/>	<input type="checkbox"/>	<input type="checkbox"/>
233	234	235	236	237	238	239	240	241	242	243	244	245	246	247	248
<input type="checkbox"/>	<input type="checkbox"/>	<input type="checkbox"/>	<input type="checkbox"/>	<input type="checkbox"/>	<input type="checkbox"/>	<input type="checkbox"/>	<input type="checkbox"/>	<input type="checkbox"/>	<input type="checkbox"/>	<input type="checkbox"/>	<input type="checkbox"/>	<input type="checkbox"/>	<input type="checkbox"/>	<input type="checkbox"/>	<input type="checkbox"/>
249	250	251	252	253	254	255	256	257	258	259	260	261	262	263	264
<input type="checkbox"/>	<input type="checkbox"/>	<input type="checkbox"/>	<input type="checkbox"/>	<input type="checkbox"/>	<input type="checkbox"/>	<input type="checkbox"/>	<input type="checkbox"/>	<input type="checkbox"/>	<input type="checkbox"/>	<input type="checkbox"/>	<input type="checkbox"/>	<input type="checkbox"/>	<input type="checkbox"/>	<input type="checkbox"/>	<input type="checkbox"/>
265	266	267	268	269	270	271	272	273	274	275	276	277	278	279	280
<input type="checkbox"/>	<input type="checkbox"/>	<input type="checkbox"/>	<input type="checkbox"/>	<input type="checkbox"/>	<input type="checkbox"/>	<input type="checkbox"/>	<input type="checkbox"/>	<input type="checkbox"/>	<input type="checkbox"/>	<input type="checkbox"/>	<input type="checkbox"/>	<input type="checkbox"/>	<input type="checkbox"/>	<input type="checkbox"/>	<input type="checkbox"/>
281	282	283	284	285	286	287	288	289	290	291	292	293	294	295	296
<input type="checkbox"/>	<input type="checkbox"/>	<input type="checkbox"/>	<input type="checkbox"/>	<input type="checkbox"/>	<input type="checkbox"/>	<input type="checkbox"/>	<input type="checkbox"/>	<input type="checkbox"/>	<input type="checkbox"/>	<input type="checkbox"/>	<input type="checkbox"/>	<input type="checkbox"/>	<input type="checkbox"/>	<input type="checkbox"/>	<input type="checkbox"/>
297	298	299	300	301	302	303	304	305	306	307					

B.11 Ademco Contact ID Format Primary Central Station (Factory Defaults)

1₁₄₅ **1**₁₄₆ **1**₁₄₇ **1**₁₄₈ **1**₁₄₉ **5**₁₅₀ **1**₁₅₁ **1**₁₅₂ **1**₁₅₃ **1**₁₅₄ **1**₁₅₅ **5**₁₅₆ **3**₁₅₇ **8**₁₅₈ **0**₁₅₉ **3**₁₆₀
8₁₆₁ **0**₁₆₂ **3**₁₆₃ **8**₁₆₄ **0**₁₆₅ **3**₁₆₆ **8**₁₆₇ **0**₁₆₈ **3**₁₆₉ **0**₁₇₀ **1**₁₇₁ **3**₁₇₂ **1**₁₇₃ **0**₁₇₄ **3**₁₇₅ **0**₁₇₆
2₁₇₇ **3**₁₇₈ **1**₁₇₉ **1**₁₈₀ **3**₁₈₁ **5**₁₈₂ **1**₁₈₃ **3**₁₈₄ **5**₁₈₅ **2**₁₈₆ **3**₁₈₇ **2**₁₈₈ **1**₁₈₉ **3**₁₉₀ **0**₁₉₁ **0**₁₉₂
3₁₉₃ **5**₁₉₄ **4**₁₉₅ **3**₁₉₆ **5**₁₉₇ **4**₁₉₈ **3**₁₉₉ **0**₂₀₀ **8**₂₀₁ **6**₂₀₂ **0**₂₀₃ **2**₂₀₄ **6**₂₀₅ **0**₂₀₆ **8**₂₀₇ **4**₂₀₈
1₂₀₉ **1**₂₁₀ **4**₂₁₁ **1**₂₁₂ **6**₂₁₃ **4**₂₁₄ **1**₂₁₅ **2**₂₁₆ **4**₂₁₇ **1**₂₁₈ **3**₂₁₉

B.12 Ademco Contact ID Format Secondary Central Station (Factory Defaults)

1₂₃₃ **1**₂₃₄ **1**₂₃₅ **1**₂₃₆ **1**₂₃₇ **5**₂₃₈ **1**₂₃₉ **1**₂₄₀ **1**₂₄₁ **1**₂₄₂ **1**₂₄₃ **5**₂₄₄ **3**₂₄₅ **8**₂₄₆ **0**₂₄₇ **3**₂₄₈
8₂₄₉ **0**₂₅₀ **3**₂₅₁ **8**₂₅₂ **0**₂₅₃ **3**₂₅₄ **8**₂₅₅ **0**₂₅₆ **3**₂₅₇ **0**₂₅₈ **1**₂₅₉ **3**₂₆₀ **1**₂₆₁ **0**₂₆₂ **3**₂₆₃ **0**₂₆₄
2₂₆₅ **3**₂₆₆ **1**₂₆₇ **1**₂₆₈ **3**₂₆₉ **5**₂₇₀ **1**₂₇₁ **3**₂₇₂ **5**₂₇₃ **2**₂₇₄ **3**₂₇₅ **2**₂₇₆ **1**₂₇₇ **3**₂₇₈ **0**₂₇₉ **0**₂₈₀
3₂₈₁ **5**₂₈₂ **4**₂₈₃ **3**₂₈₄ **5**₂₈₅ **4**₂₈₆ **3**₂₈₇ **0**₂₈₈ **8**₂₈₉ **6**₂₉₀ **0**₂₉₁ **2**₂₉₂ **6**₂₉₃ **0**₂₉₄ **8**₂₉₅ **4**₂₉₆
1₂₉₇ **1**₂₉₈ **4**₂₉₉ **1**₃₀₀ **6**₃₀₁ **4**₃₀₂ **1**₃₀₃ **2**₃₀₄ **4**₃₀₅ **1**₃₀₆ **3**₃₀₇

Appendix C: Ademco Contact ID Format Event Code Description

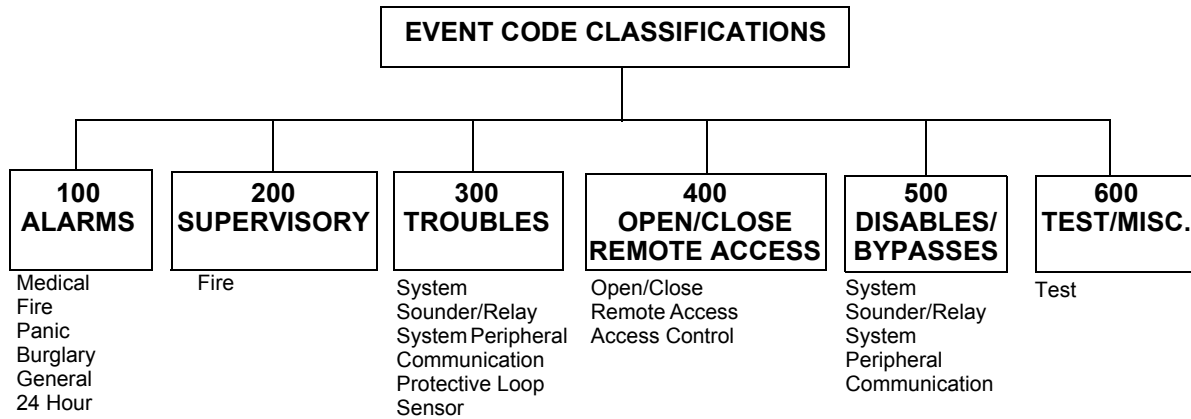

EVENT

MESSAGE

Medical Alarms - 100

100 Medical	EMERG - Personal Emergency - #
101 Pendant transmitter	EMERG - Personal Emergency - #
102 Fail to report in	EMERG - Fail to Check-in - #

Fire Alarms - 110

110 Fire Alarm	FIRE - Fire Alarm - #
111 Smoke	FIRE - Smoke Detector - #
112 Combustion	FIRE - Combustion - #
113 Waterflow	FIRE - Waterflow - #
114 Heat	FIRE - Heat Sensor - #
115 Pull Station	FIRE - Pull Station - #
116 Duct	FIRE - Duct Sensor - #
117 Flame	FIRE - Flame Sensor - #
118 Near Alarm	FIRE - Near Alarm - #

Panic Alarms - 120

120 Panic Alarm	PANIC - Panic - #
121 Duress	PANIC - Duress - #
122 Silent	PANIC - Silent Panic - #
123 Audible	PANIC - Audible Panic - #

Burglar Alarms - 130

130 Burglary	BURG - Burglary - #
131 Perimeter	BURG - Perimeter - #
132 Interior	BURG - Interior - #
133 24-Hour	BURG - 24-Hour - #
134 Entry/Exit	BURG - Entry/Exit
135 Day/Night	BURG - Day/Night
136 Outdoor	BURG - Outdoor - #

EVENT	MESSAGE
137 Tamper	BURG - Tamper - #
138 Near Alarm	BURG - Near Alarm - #
<u>General Alarms - 140</u>	
140 General Alarm	ALARM - General Alarm - #
141 Polling loop open	ALARM - Polling Loop Open - #
142 Polling loop short	ALARM - Polling Loop Short - #
143 Expansion module failure	ALARM - Exp. Module Fail - #
144 Sensor tamper	ALARM - Sensor Tamper - #
145 Expansion module tamper	ALARM - Exp. Module Tamper - #
<u>24 Hour Non-Burglary - 150 and 160</u>	
150 24-Hour Non-Burg	ALARM - 24-Hr. Non-Burg - #
151 Gas detected	ALARM - Gas Detected - #
152 Refrigeration	ALARM - Refrigeration - #
153 Loss of heat	ALARM - Heating System - #
154 Water leakage	ALARM - Water Leakage - #
155 Foil break	ALARM - Foil Break - #
156 Day trouble	ALARM - Day Zone - #
157 Low bottled gas level	ALARM - Low Gas Level - #
158 High temp	ALARM - High Temperature - #
159 Low temp	ALARM - Low Temperature - #
161 Loss of air flow	ALARM - Air Flow - #
<u>Fire Supervisory - 200 and 210</u>	
200 Fire Supervisory	SUPER. - Fire Supervisory - #
201 Low water pressure	SUPER. - Low Water Pressure - #
202 Low CO2	SUPER. - Low CO2
203 Gate valve sensor	SUPER. - Gate Valve - #
204 Low water level	SUPER. - Low Water Level - #
205 Pump activated	SUPER. - Pump Activation - #
206 Pump failure	SUPER. - Pump Failure - #
<u>System Troubles - 300 and 310</u>	
300 System trouble	TROUBLE - System Trouble
301 AC loss	TROUBLE - AC Power
302 Low system battery	TROUBLE - System Low Battery
303 RAM checksum bad	TROUBLE - Bad RAM Checksum (Restore not applicable)
304 ROM checksum bad	TROUBLE - Bad ROM Checksum (Restore not applicable)
305 System reset	TROUBLE - System Reset (Restore not applicable)
306 Panel program changed	TROUBLE - Programming Changed (Restore not applicable)
307 Self-test failure	TROUBLE - Self Test Failure
308 System shutdown	TROUBLE - System Shutdown
309 Battery test failure	TROUBLE - Battery Test Failure
310 Ground fault	TROUBLE - Ground Fault - #
311 No battery	TROUBLE - No Battery
<u>Sounder/Relay Troubles - 320</u>	
320 Sounder/Relay	TROUBLE - Sounder Relay - #
321 Bell 1	TROUBLE - Bell/Siren #1
322 Bell 2	TROUBLE - Bell/Siren #2

EVENT	MESSAGE	
323 Alarm relay	TROUBLE - Alarm Relay	
324 Trouble relay	TROUBLE - Trouble Relay	
325 Reversing	TROUBLE - Reversing Relay	
326 Bell 3	TROUBLE - Bell/Siren #3	
327 Bell 4	TROUBLE - Bell/Siren #4	
<u>System Peripheral Troubles - 330 and 340</u>		
330 System Peripheral	TROUBLE - Sys. Peripheral - #	
331 Polling loop open	TROUBLE - Polling Loop Open	
332 Polling loop short	TROUBLE - Polling Loop Short	
333 Expansion module failure	TROUBLE - Exp. Module Fail - #	
334 Repeater failure	TROUBLE - Repeater Failure - #	
335 Local printer paper out	TROUBLE - Printer Paper Out	
336 Local printer failure	TROUBLE - Local Printer	
<u>Communication Troubles - 350 and 360</u>		
350 Communication	TROUBLE - Communication Trouble	
351 Telco 1 fault	TROUBLE - Phone Line #1	
352 Telco 2 fault	TROUBLE - Phone Line #2	
353 Long range radio xmitter fault	TROUBLE - Radio Transmitter	
354 Fail to communicate	TROUBLE - Fail to Communicate	
355 Loss of radio supervision	TROUBLE - Radio Supervision	
356 Loss of central polling	TROUBLE - Central Radio Polling	
<u>Protection Loop Troubles - 370</u>		
370 Protection loop	TROUBLE - Protection Loop - #	
371 Protection loop open	TROUBLE - Protection Loop Open - #	
372 Protection loop short	TROUBLE - Protection Loop Short - #	
373 Fire Trouble	TROUBLE - Fire Loop - #	
<u>Sensor Troubles - 380</u>		
380 Sensor trouble	TROUBLE - Sensor Trouble - #	
381 Loss of Supervision - RF	TROUBLE - RF Sensor Supervision - #	
382 Loss of Supervision - RPM	TROUBLE - RPM Sensor Supervision - #	
383 Sensor tamper	TROUBLE - Sensor Tamper - #	
384 RF transmitter low battery	TROUBLE - RF Sensor Batt. - #	
<u>Open/Close - 400</u>		
400 Open/Close	OPENING	CLOSING
401 Open/Close by user	OPENING - User #	CLOSING - User #
402 Group Open/Close	OPENING - Group User #	CLOSING - Group User #
403 Automatic Open/Close	OPENING - Automatic	CLOSING - Automatic
404 Late Open/Close	OPENING - Late	CLOSING - Late
405 Deferred Open/Close	Opening not used	Closed not used
406 Cancel	OPENING - Cancel	Closed not used
407 Remote arm/disarm	OPENING - Remote	CLOSING - Remote
408 Quick arm	Opening not applicable	CLOSING - Quick Arm
409 Keyswitch Open/Close	OPENING - Keyswitch	CLOSING - Keyswitch
<u>Remote Access - 410</u>		
411 Callback request made	REMOTE - Callback Requested	Restore not applicable

EVENT	MESSAGE	
412 Success - download/access	REMOTE - Successful Access	Restore not applicable
413 Unsuccessful access	REMOTE - Unsuccessful Access	Restore not applicable
414 System shutdown	REMOTE - System Shutdown	
415 Dialer shutdown	REMOTE - Dialer Shutdown	
416 Success - upload/access	REMOTE - Successful Access	Restore not applicable
 <u>Access Control - 420</u>		
421 Access denied	ACCESS - Access Denied - User #	Restore not used
422 Access report by user	ACCESS - Access Gained - User #	Restore not used
 <u>System Disables - 500 and 510</u>		
 <u>Sounder/Relay Disables - 520</u>		
520 Sounder/Relay disable	DISABLE - Sounder/Relay - #	
521 Bell 1 disable	DISABLE - Bell/Siren - #1	
522 Bell 2 disable	DISABLE - Bell/Siren - #2	
523 Alarm relay disable	DISABLE - Alarm Relay	
524 Trouble relay disable	DISABLE - Trouble Relay	
525 Reversing relay disable	DISABLE - Reversing Relay	
526 Bell 3 disable	DISABLE - Bell/Siren - #3	
527 Bell 4 disable	DISABLE - Bell/Siren - #4	
 <u>System Peripheral Disables - 530 and 540</u>		
 <u>Communication Disables - 550 and 560</u>		
551 Dialer disabled	DISABLE - Dialer Disable	
552 Radio transmitter disabled	DISABLE - Radio Disable	
 <u>Bypasses - 570</u>		
570 Zone bypass	BYPASS - Zone Bypass - #	
571 Fire bypass	BYPASS - Fire Bypass - #	
572 24-Hour zone bypass	BYPASS - 24-Hour Bypass - #	
573 Burglar bypass	BYPASS - Burg. Bypass - #	
574 Group bypass	BYPASS - Group Bypass - #	
 <u>Test Misc. - 600</u>		
601 Manual trigger test	TEST - Manually Triggered	Restore not applicable
602 Periodic test report	TEST - Periodic	Restore not applicable
603 Periodic RF transmission	TEST - Periodic Radio	Restore not applicable
604 Fire test	TEST - Fire Test	Restore not used
605 Status report to follow	STATUS - Status Follows	Restore not applicable
606 Listen-in to follow	LISTEN - Listen-in Active	Restore not applicable
607 Walk test mode	TEST - Walk Test Mode	
608 System abnormal test	TEST - System Abnormal Test	

Appendix D: Events and Default Event Codes

Note: The character 'x' in the following table refers to the input circuit number (1 - 4).

411UDAC Events	Format Group 1		Format Group 2		Ademco Contact ID	
Input Circuit Functions	Active	Restore	Active	Restore	Active and Restore	Sensor #
4-wire Smoke	1x	Ex	1	E	111	00x
Pull Station	1x	Ex	1	E	115	00x
Contact Closure	1x	Ex	1	E	110	00x
Host Control Panel Trouble	FF	Ex	F	E	373	00x
Latching Supervisory	8x	Ex	8	E	200	00x
Autoresettable Supervisory	8x	Ex	8	E	200	00x
Silenceable Waterflow	1x	Ex	1	E	113	00x
Nonsilenceable Waterflow	1x	Ex	1	E	113	00x
Other Events	Active	Restore	Active	Restore	Active and Restore	Sensor #
Input Circuit Fault	Fx	Dx	F	D	380	00x
AC Fault	92	93	9	9	301	000
Earth Fault	61	A1	6	A	310	000
Low Battery Fault	62	A2	6	A	302	000
No Battery Fault	63	A3	6	A	311	000
Phone Line 1 Fault	64	A4	6	A	351	000
Phone Line 2 Fault	65	A5	6	A	352	000
NAC Fault	66	A6	6	A	321	000
Phone Number 1 Fault	6A	AA	6	A	354	001
Phone Number 2 Fault	6B	AB	6	A	354	002
System Off Normal Fault	6F	AF	6	A	308	000
Special Events	Active	Restore	Active	Restore	Active and Restore	Sensor #
System Test Message	99	-	9	-	602	000
System Abnormal Test Message	91	-	F	-	608	000
Upload/Download Request	71	-	7	-	411	000
Upload Successful	72	-	7	-	416	000
Download Successful	73	-	7	-	412	000
Upload/Download Failed	74	-	7	-	412	000

Group Definitions:

Format Group 1

4+2 Ademco Express Standard, DTMF	1400/2300 Hz ACK
4+1 Expanded 1800 Hz Carrier	2300 Hz ACK
4+1 Expanded 1900 Hz Carrier	1400 Hz ACK
4+2 Standard 1800 Hz Carrier	2300 Hz ACK
4+2 Expanded 1800 Hz Carrier	2300 Hz ACK
4+2 Standard 1900 Hz Carrier	1400 Hz ACK
4+2 Expanded 1900 Hz Carrier	1400 Hz ACK

Format Group 2

4+1 Ademco Express Standard, DTMF	1400/2300 Hz ACK
3+1 Expanded 1800 Hz Carrier	2300 Hz ACK
3+1 Expanded 1900 Hz Carrier	1400 Hz ACK
3+1 Standard 1800 Hz Carrier	2300 Hz ACK
3+1 Standard 1900 Hz Carrier	1400 Hz ACK
4+1 Standard 1800 Hz Carrier	2300 Hz ACK
4+1 Standard 1900 Hz Carrier	1400 Hz ACK

Note that although all Expanded Mode formats communicate two digits per event, only the first digit is programmable. The second digit cannot be changed.

Appendix E: Operational Modes

CODE	ACTIVITY	NOTES
6676 (NORM)	Returns to normal operation	Fire protection is on.
2525 (CLCK)	Enters Real-Time Clock Mode	Program digital communicator time. Fire protection is off.
7764 (PROG)	Enters Program Mode	Allows programming of digital communicator. Fire protection is off.
3337 (DEFP)	Returns digital communicator to factory default program settings	Fire protection is off during Default Mode.
8768 (TROU)	Allows display of status for all circuits	Fire protection is off during Troubleshoot Mode.

Index

A

AC Loss Reporting Delay **45**
Acknowledge/System Silence **11**
Alarm Verification **10, 48**
Autosilence **10, 48**

B

Battery
 see also Secondary Power
board revision level **9**

C

Cabinet **15**
 Dimensions **19**
 Knockouts **19**
Channels/Inputs **12, 13**
 Alarm Current **12**
 End-of-Line Resistor **12**
 Loop Resistance **12**
 Operating Voltage **12**
 Operation **12**
 see also Input Channels
 Short Circuit Current **12**
Computer
 see Service Terminal
Connection **24**
Controls **14**

D

Default Mode **51**
Delay Timer **46**
Dialer Runaway **10, 11**
Digital Communicator **15**
Downloading **62**

E

Earth Ground **13**

F

Fire•Watch 411 **15**
Form-C Relays
 contact rating **12**
 operating voltage **12**
 programmable **13**
 See also Relays
Front Panel Indicator
 AC Power **14**
 Active **14**
 Battery Trouble **14**
 Communication Fail **14**

Earth Fault **14**
Supervisory **14**
System Trouble **14**
Front Panel Switch
 Acknowledge/System Silence **14**
 Reset **14**
Function Selections
 Channel **46**
 Relays **47**

I

Indicators **14**
Input Channels **10, 22**

M

Mounting **18**

N

Notification Appliance Circuit **10, 13, 25**
 Current **12**
 End-of-line resistor **12**
 Operating Voltage **12**
 Style Y **12**

O

Operating Power
 connections **21**
 Primary **20**
 Secondary **21**
 see also Battery
Operational Modes
 Default Mode **16, 51**
 Normal Mode **16, 30**
 Program Mode **16, 34**
 Real Time Clock Mode **16, 33**
 Troubleshoot Mode **16, 52**
Output Circuits **25**
 battery charger **13**
 resettable power **13**
 telephone circuits **13**
 see also Telephone Circuits

P

Panel Configuration
 Nonlatching Slave Panel Communicator
 16
 Test Mode **16**
Piezo Sounder **14**
PK-411 **11, 15**
Primary Power **12**

See also Operating Power - Primary
PRO-411. See also Fire•Watch 411 **15**
Product Features **10**

R

Receivers

UL Listed **59**

Resettable Power

current **12**

operating voltage **12**

Resistor, End-of-Line

Channels/Inputs **12**

Notification Appliance Circuit **12**

Restoral Methods **11, 49**

revision level **9**

S

Secondary Power

Battery Charging Circuit **12**

Charger Capacity **12**

See also 'Battery' and 'Operating Power -
Secondary'

Security Features **61**

Service Terminal **10, 51**

Signal Silence Inhibit **10, 48**

Simultaneous Data Transfers **63**

Stand-alone Fire Alarm Communicator **16**

T

Telephone Circuits **17, 27**

Transformer **15**

Transmittal Priorities **57**

trouble call limit **50**

Trouble Reminder **10, 45**

Trouble Resound **10**

U

UL Power-limited Wiring Requirements **29**

Uploading **62**

Manufacturer Warranties and Limitation of Liability

Manufacturer Warranties. Subject to the limitations set forth herein, Manufacturer warrants that the Products manufactured by it in its Northford, Connecticut facility and sold by it to its authorized Distributors shall be free, under normal use and service, from defects in material and workmanship for a period of thirty six months (36) months from the date of manufacture (effective Jan. 1, 2009). The Products manufactured and sold by Manufacturer are date stamped at the time of production. Manufacturer does not warrant Products that are not manufactured by it in its Northford, Connecticut facility but assigns to its Distributor, to the extent possible, any warranty offered by the manufacturer of such product. This warranty shall be void if a Product is altered, serviced or repaired by anyone other than Manufacturer or its authorized Distributors. This warranty shall also be void if there is a failure to maintain the Products and the systems in which they operate in proper working conditions.

MANUFACTURER MAKES NO FURTHER WARRANTIES, AND DISCLAIMS ANY AND ALL OTHER WARRANTIES, EITHER EXPRESSED OR IMPLIED, WITH RESPECT TO THE PRODUCTS, TRADEMARKS, PROGRAMS AND SERVICES RENDERED BY MANUFACTURER INCLUDING WITHOUT LIMITATION, INFRINGEMENT, TITLE, MERCHANTABILITY, OR FITNESS FOR ANY PARTICULAR PURPOSE. MANUFACTURER SHALL NOT BE LIABLE FOR ANY PERSONAL INJURY OR DEATH WHICH MAY ARISE IN THE COURSE OF, OR AS A RESULT OF, PERSONAL, COMMERCIAL OR INDUSTRIAL USES OF ITS PRODUCTS.

This document constitutes the only warranty made by Manufacturer with respect to its products and replaces all previous warranties and is the only warranty made by Manufacturer. No increase or alteration, written or verbal, of the obligation of this warranty is authorized. Manufacturer does not represent that its products will prevent any loss by fire or otherwise.

Warranty Claims. Manufacturer shall replace or repair, at Manufacturer's discretion, each part returned by its authorized Distributor and acknowledged by Manufacturer to be defective, provided that such part shall have been returned to Manufacturer with all charges prepaid and the authorized Distributor has completed Manufacturer's Return Material Authorization form. The replacement part shall come from Manufacturer's stock and may be new or refurbished. THE FOREGOING IS DISTRIBUTOR'S SOLE AND EXCLUSIVE REMEDY IN THE EVENT OF A WARRANTY CLAIM.

Warn-HL-08-2009.fm

