

FDD FIRE DETECTION DEVICES LTD.

Heat Detector – Single Circuit – Sealed

- Combination Rate-of-Rise & Fixed Temperature
Ask for CR 135 MP, CR 165 MP, CR 200 MP
- Fixed Temperature Only
Ask for CF 135 MP, CF 165 MP, CF 200 MP, CF 285 MP

Description:

- This is the standard THERMOFLEX™ single circuit, Normally Open contacts detector, in which the connectivity is modified with pigtail leads that extend through a seal plate. This provides for enhanced protection against corrosive or moisture-laden environments.
- **Combination Rate-of-Rise & Fixed Temperature**
The Model Number prefix “CR” indicates that the detector is a combination Rate-of-Rise and Fixed Temperature, (often referred to as “Dual-action”), unit. The Rate-of-Rise function allows the detector to close its contacts when the temperature at the ceiling increases at a rate of 8.4 Celsius degrees (15 Fahrenheit degrees) per minute. The closure of the contacts initiates the Fire Alarm sequence. The Fixed Temperature portion consists of a spring-loaded plunger held in place by a eutectic solder that will fuse at the specific temperature (in Fahrenheit degrees) as indicated by the Model Number i.e. 135, 165 and 200 degrees.
- **Fixed Temperature Only**
The Model Number prefix “CF” indicates that the detector is Fixed Temperature Only, and will therefore *not* respond to a rate of temperature increase but will operate when the detector fuses at the prescribed (Fahrenheit) temperature as indicated by the model number, i.e. 135, 165, 200 and 285 degrees. This detector is referred to as “Fixed Temperature Only, non-restorable”.
- **Application**
This detector is suitable for use in areas where condensation or corrosion can have harmful effects on circuit wiring connected to standard terminals. Its seal plate (with extended pigtail leads) will mount onto a typical cast exterior back box. The detector is connected to a fire alarm system’s input circuit as an initiating device. The internal contacts are normally open, and will close when the detector operates either on a rate of temperature increase, or if the releasing temperature is reached. It is often installed with an addressing module if it is to be annunciated as a specific room or space, e.g. electrical room, garbage compactor, etc. With its non-metallic diaphragm, the detector can operate normally at low temperatures, making it suitable for non-heated or chilled environments including garages and carports.

Engineering Specification:

- Models CR 135 MP, CR 165 MP and CR 200 MP detectors are *dual-action* type, that will respond to a rate of temperature increase at the ceiling of 15 Fahrenheit degrees per minute (8.4 Celsius degrees per minute). These detectors will also respond when the fixed temperature (non-restorable) threshold is exceeded. Dual-action detectors are installed in areas where rapid fluctuations in ceiling temperature are *not* expected.
- In areas where sudden increases in ceiling temperature are normal, specify Fixed Temperature Only units i.e. CF 135 MP, CF 165 MP, CF 200 MP or CF 285 MP.
- Detectors shall be installed in areas where environmental conditions including moisture, dust, vapours, insects, low temperatures, etc., would cause an ionization or photoelectric type detector to initiate a false alarm.
- Detectors shall have a proven operating temperature range of; -20°F/+250°F (-30°C/-120°C) exclusive of releasing temperature.
- The fusible link mechanism, when operated, shall be held firmly in place such that the contacts are prohibited from changing state, i.e. reverting back to the normal position.

Temperature and Spacing Chart – sealed unit

Model #	Function Type	Release Temp.	Temp. Rating	Max. Installation Temp	Color dot on fin	Inter-detector Spacing*
CR 135	Dual-action	135°F / 57°C	Ordinary	100°F / 37.8°C	None	70ft / 21m
CR 165	Dual-action	165°F / 71°C	Ordinary	100°F / 37.8°C	Grey	70ft / 21m
CR 200	Dual-action	200°F / 93°C	Intermediate	150°F / 65.6°C	White	70ft / 21m
CF 135	Fixed Temp. Only	135°F / 57°C	Ordinary	100°F / 37.8°C	Black	40ft / 12m
CF 165	Fixed Temp. Only	165°F / 71°C	Ordinary	100°F / 37.8°C	Black and Grey	25ft / 7.5m
CF 200	Fixed Temp. Only	200°F / 93°C	Intermediate	150°F / 65.6°C	Black and White	25ft / 7.5m
CF 285	Fixed Temp. Only	285°F / 140°C	High	225°F / 107.2°C	Black and Blue	25ft / 7.5m

* assumes a flat, uninterrupted ceiling at a height not exceeding 10ft / 3m.

Installation:

On conventional, initiating circuits, or when using an addressing module, contacts are installed across the circuit such that operation of the detector will create a short circuit condition, required in order to activate the fire alarm control panel (FACP), or addressing module.

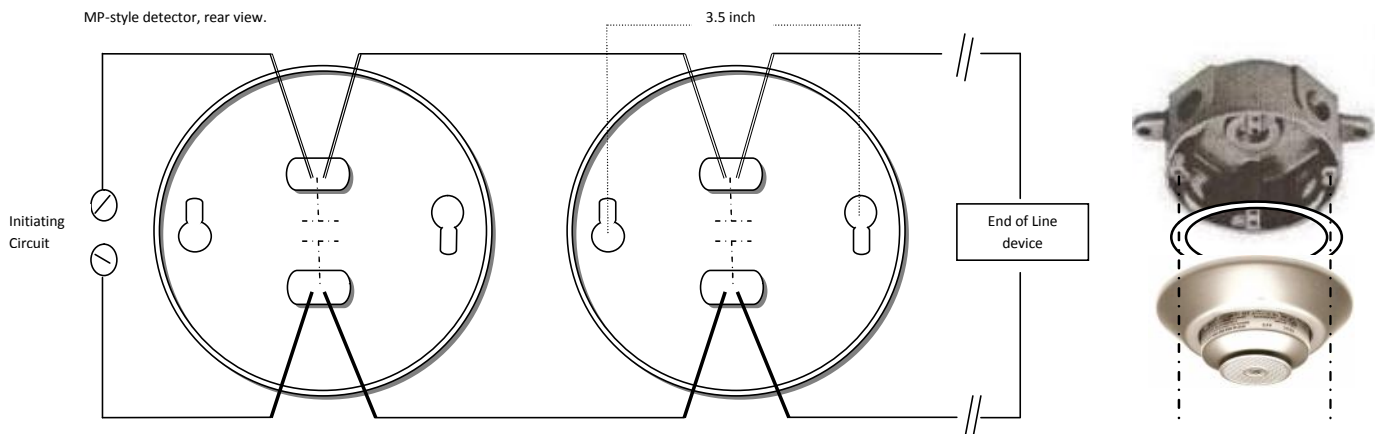

The detector is installed using rain-tight conduit and a standard, approved weatherproof electrical enclosure as shown above. A neoprene (or similar gasket supplied with the back box), is installed between the detector's seal plate and the back box. The wire leads are connected to the initiating circuit inside the enclosure. Unused threaded openings are sealed with threaded plugs. A decorative anodized aluminum cover ring snaps over the detector to complete the installation.

Contact Electrical Rating:

3A @ 125 VAC, 1A @ 28 VDC,
0.3A @ 125 VDC, 0.1 A @ 250 VDC

Testing:

- **Testing the “CR” series detector**

Testing the Rate-of-Rise portion, is accomplished by applying heat from a controlled heat source, such as a hair blow dryer, held 8-12 inches away and aimed at the detector. The detector will respond within 6-10 seconds. Providing that the fusible link has not released, the detector will restore as it cools.

NOTE: A heat gun should not be used as the heat output can easily fuse the detector.

- Portable test units designed specifically for this purpose are acceptable, and must be UL listed.
- Care must be taken to *not allow* the heat source to reach the device’s fusing temperature. If the detector’s fusing temperature is reached and the plunger is released, the detector will be in permanent alarm and must be replaced.
- Devices using open flame are prohibited from testing heat detectors. (ULC S536, ULC S537).

- **Testing the “CF” series detector**

The Fixed Temperature Only detector, *cannot be tested by warming the unit* as permanent contact closure may result, requiring replacement of the detector. Shorting across the wire leads connected to the fire alarm input circuit will confirm the circuit function and Zone identification.

Fire Detection Devices Ltd. heat detectors for fire alarm systems comply with UL 521 *Heat Detectors for Fire Protective Signaling Systems*, and ULC S531 *Standard for Heat Actuated Fire Detectors for Fire Alarm Systems*. The UL/ULC control number is 41H9, file number S2406. CSFM listing # 7270-1110:0100. Detectors featuring wire (pigtail) leads are included in these documents.