



Detex Corporation, 302 Detex Drive, New Braunfels, Texas 78130-3045
830-629-2900 / 800-729-3839 / Fax 800-653-3839 / Text photos only: 830-481-6433 / INTERNET: www.detex.com

INSTALLATION INSTRUCTIONS FOR 80/F80/81/F81 SERIES CVR METAL DOOR CONCEALED



Concealed Vertical Rod Exit Device
80 / F80 / 81 / F81 Series
for Hollow Metal door applications
Drawing No. 105280

Table of Contents	Page
Device parts breakdown view.....	2
Device parts breakdown list with part numbers.....	3
Hardware List with part numbers & tools required.....	4
Step 1: Door/opening measurements.....	5
Step 2: Door & frame prep	6
Step 3: Top rod assembly and initial adjustment	7 & 8
Step 4: Bottom rod / latch assembly initial adjustment	9
Step 5: Visual alignment check	10
Step 6: Install top latch mounting bracket	11
Step 7: Insert rod / latch / centerlift assembly into door	11
Step 8: Secure rod / latch / centerlift assembly to door	12
Step 9: Verify centerlift mechanism operation	13
Step 10: Hang door / assemble device to door	14
Check device for clearance	15
Install mortise cylinder	15
Step 11: Install top strike.....	16
Step 12: Install bottom strike.....	16
Step 13: Fine latch adjustment	17
Step 14: Install covers	18
Step 15: Install auxiliary bolt.....	18
Optional accessories	19

For WARRANTY information,
scan code below or
go to www.detex.com/warranty



Owner's Copy

For device installation videos,
scan code below or
go to www.detex.com/videos



Should you have a Question/Problem with your Detex device please call Detex Technical Support from the job site at 1-800-729-3839 and choose option 2 on our menu. Please do not return the product to the distributor.

Device Parts Breakdown View

*** Note:**

Parts listed will vary according to product configuration.
 Mortise cylinder available as an option. Standard Yale type cam required.
 See Mortise cylinder installation page.

Your particular part or configuration may not be shown:
 Contact Detex technical support at 800-729-3839 (option 2)

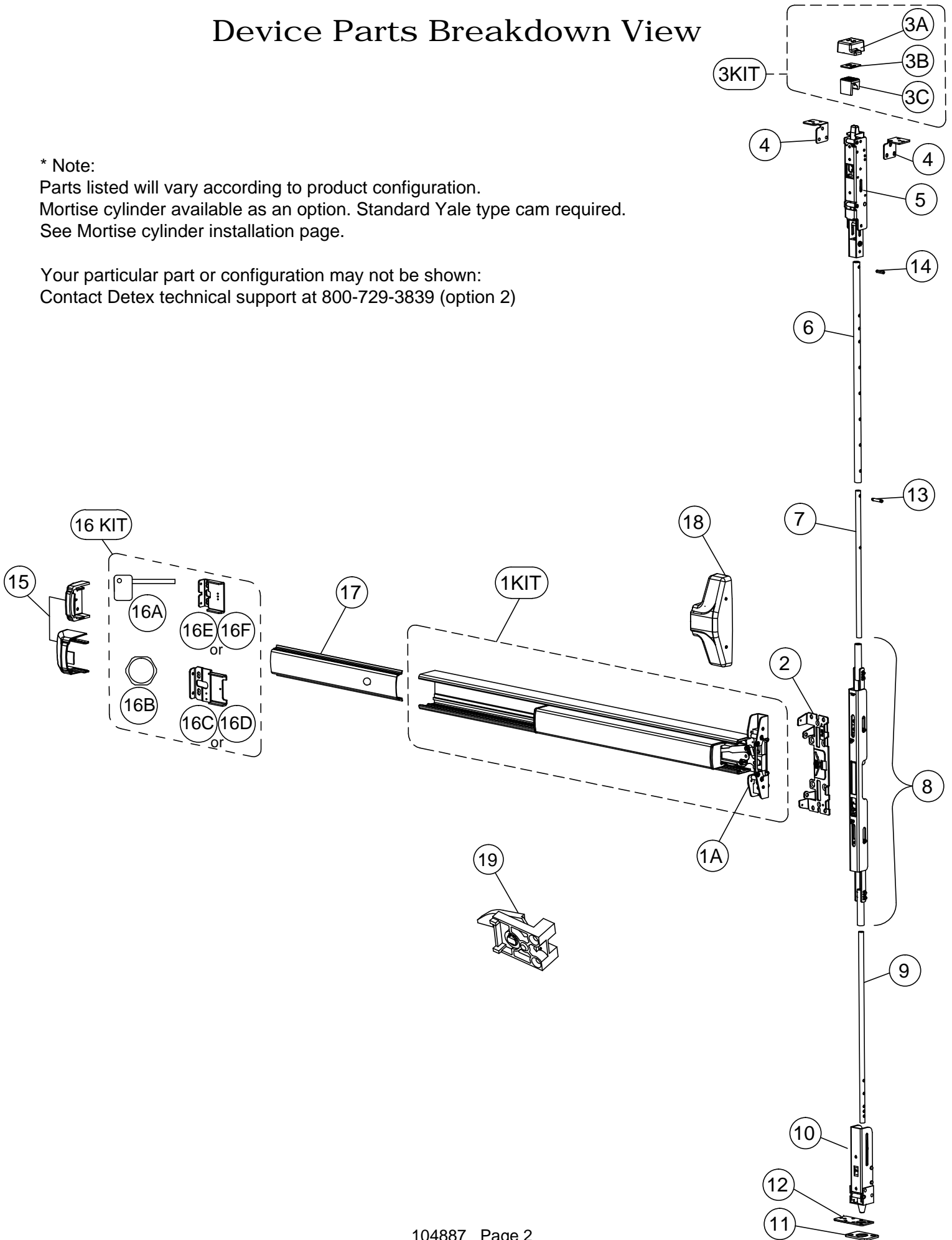







Device Parts Breakdown Part Numbers

ITEM	PART #	DESCRIPTION
1KIT	105500-160	S&R 80 x STD1 x RHR Centercase/Pushpad Assy
	105500-161	S&R 80 x STD1 x LHR Centercase/Pushpad Assy
1A	104111-3	Centercase, CVR, Wide, RHR
	104111-4	Centercase, CVR, Wide, LHR
2	104171-1	Mounting plate, Wide, CVR, BP11 (Use with 08/09 lever trim)
	104171-2	Mounting plate, Wide, CVR, BP13 (Use with 03 trim)
3KIT	105257-2	Top strike kit
3A	105235-1	CVR top strike pocket
3B	105246	CVR strike shim
3C	105236-1	CVR top strike insert
4	104123-1	Top latch mounting bracket RHR
	104123-2	Top latch mounting bracket LHR
5	104121-1	Top latch (Panic)
	104121-2	Top latch (Fire)
6	104187	Outer top rod, 7' thru 8'
	105097	Outer top rod, 8'-1" thru 10'
7	104172-1	Inner top rod, 7' thru 8'
	104172-2	Inner top rod, 8'-1" thru 10'
8	105990-1	Center lift mechanism assembly, Top & Bottom
	105990-2	Center lift mechanism assembly, Top Rod Only
9	105098	CVR bottom rod
10	104190-2	Bottom latch, HM application
11	105257-3	Bottom strike kit, 95B
12	104166	Bottom latch mounting bracket
13	103423	Spring pin 3/16 x 1/2
14	105296	Spring pin 3/16 x 13/16
15	101642-9	Endcap, EC1 (ramped) Stainless Steel 630
	104304-9	Endcap, EC2 (flush) Stainless Steel 630
16KIT	106431-1	Device Hardware Kit, HD, EC1 (not all components shown, includes Items 16A & 16C)
	106431-2	Device Hardware Kit, CD, EC1 (not all components shown, includes Items 16B & 16C)
	106431-3	Device Hardware Kit, EA, EC1 (not all components shown, includes Items 16B & 16D)
	106431-21	Device Hardware Kit, HD, EC2 (not all components shown, includes Items 16A & 16E)
	106431-22	Device Hardware Kit, CD, EC2 (not all components shown, includes Items 16B & 16E)
	106431-23	Device Hardware Kit, EA, EC2 (not all components shown, includes Items 16B & 16F)
16A	100450	Hex Key (for Hex Dogging)
16B	100783	Cylinder Nut (for Cylinder Dogging)
16C	100147	Endcap bracket for EC1 (ramped) endcap w/o battery holder
16D	101093	Endcap bracket for EC1 (ramped) endcap w/ battery holder
16E	104303	Endcap bracket for EC2 (flush) endcap w/o battery holder
16F	104636	Endcap bracket for EC2 (flush) endcap w/ battery holder
17	100860-165	Fillerplate Subassembly, S&R, Hex Dogging, HD, 630
18	102353-9	Centercase Cover, Stainless Steel, Wide 630
19	102216-2	Hex Dogging Assembly
	102216	Cylinder Dogging Assembly

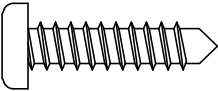
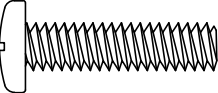
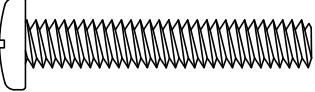
Your particular part or configuration may not be shown: Contact Detex technical support at 800-729-3839 (option 2)

Hardware Table for BASIC device mounting. Additional hardware is provided per the device configuration in kit form and is addressed on the appropriate pages as required.

Device Mounting Hardware

	#14 x 1" PPHS P/N: PP-5183-108	Used to install backplate & endcap bracket to door. Drill Bit - 3/16 pilot hole x 1" deep
	1/4-20 x 1" PPH P/N: 100980	Used with sex bolts or lever trim (1-3/4 door). Drill Bit - #7 or 13/64"
	1/4-20 x 1-1/2" PPH P/N: 100954	ALTERNATE SCREW Used with sex bolts or lever trim (2" plus door) Drill Bit - #7 or 13/64"
	10-24 x 1/4" PPH P/N: PP-5304-104	Used to install device centercase to backplate
	10-24 x 5/8" PFHU P/N: 100112	Used to install centerlift mechanism to backplate
	10-32 x 5/16" PFHU P/N: 101632-2	Used to install endcap to endcap bracket. (Multiple finishes included)
	6-32 x 3/8" PFHU P/N: 100162-106	Used to install centercase cover to backplate (Multiple finishes included)
	1/4" Lockwasher P/N: PP-5067-25	Lockwashers

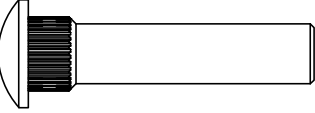

Sex nuts, if ordered. Sex nuts are used with screws in device hardware kit.

	1/4-20 x 1.60 Sex nut P/Ns: 105274-9 (Stainless Steel) 105274-2 (Brushed Brass) 105274-25 (Oil Rub Bronze)	Used to install backplate and endcap bracket to door If using sex nuts with TRIM: Drill 9/32 hole through interior door face. Drill 1/2 hole through exterior door face. If using sex nuts without TRIM: Drill 3/8 hole through exterior door face.
---	--	--

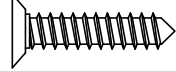
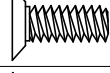
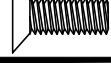
Strike Mounting Hardware

	#10 x 1" PFHU P/N: 100109	Used to install bottom strike to floor. (Used with anchors, two styles of anchors included)
	10-24 x 1/2" PFHU P/N: 100112-108	Used to install bottom strike to floor (alternate)
	10-32 x 1/2" PFH P/N: PP-5802-308	Used to install top strike pocket to header and strike insert to top strike pocket

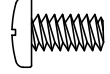
Latch Mounting Hardware

	10-24 x 5/16" PFH P/N: 100112-105	Used to install bracket to bottom assembly and top latch
	10-24 x 3/8" PPH P/N: PP-5304-306	Hollow Metal / Wood doors: bottom bracket to latch Hollow Metal doors: Top & bottom latch brackets to door
	#10 x 3/4" PPHS P/N: PP-5183-66	Used to install bottom assembly to bottom of door & top latch to top of door (For NON-FIRE RATED)

Tools Required

Power Drill
Level
Screw Drivers

Hammer
Pencil
Center Punch

Drill Bit Set
Pliers

Safety Glasses
Tape Measure

Hack Saw (Chopsaw preferred)
Tap Wrench/ Hex Wrench - 5/64
Masonry Bits - 3/16", 5/16" & 1"

!!!CHECK BEFORE STARTING!!!

Doors and frames with walls having a structural thickness (metal skin plus reinforcement) to engage less than (3) full screw threads, are considered unreinforced for hardware.

Unreinforced Doors: Use Sex Nuts and Bolts
 Unreinforced Frames: Use Blind Rivet Nuts (see sketch).
 Fasteners for unreinforced openings are not supplied by Detex.

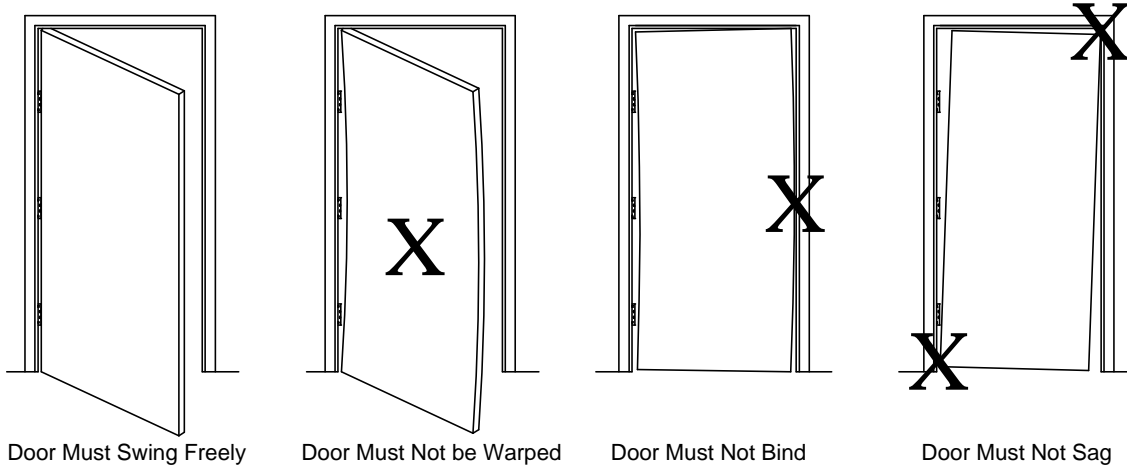
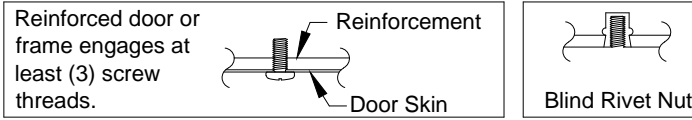

NOTE: LOCAL CODES MAY REQUIRE THROUGH BOLTING. SEX NUTS ARE **NOT** INCLUDED WITH THIS DEVICE. SEX NUTS CAN BE PURCHASED SEPARATELY.

STEP 1: DOOR / OPENING MEASUREMENTS

Measure per figure below:

*These dimensions will be needed during rod length adjustment. Measure door before removing.

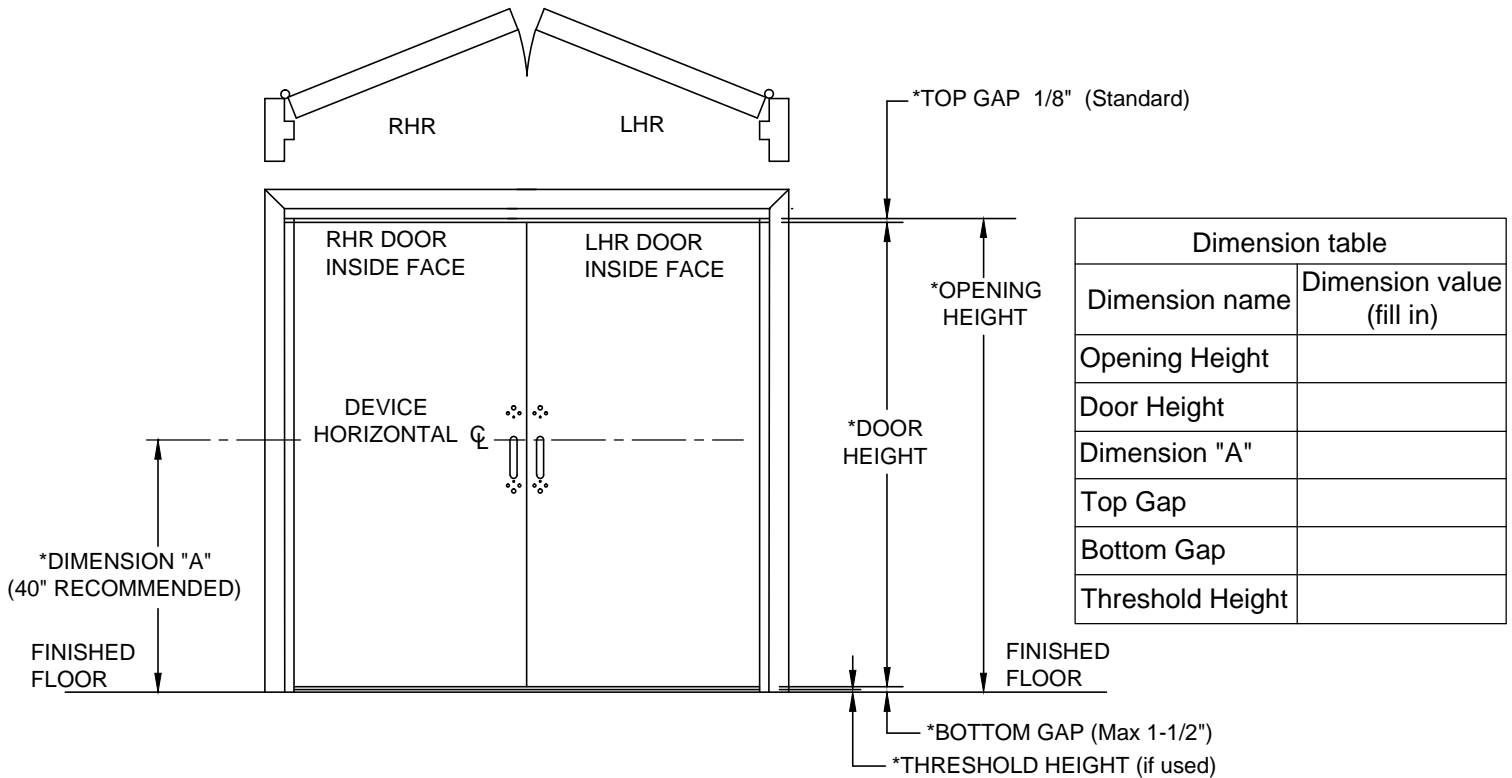

STEP 2: DOOR PREP - HOLLOW METAL DOOR

INSTALLATION SHOWN IN THIS INSTRUCTION IS FOR
 RIGHT HAND REVERSE (RHR)
 LEFT HAND REVERSE (LHR) WILL BE OPPOSITE

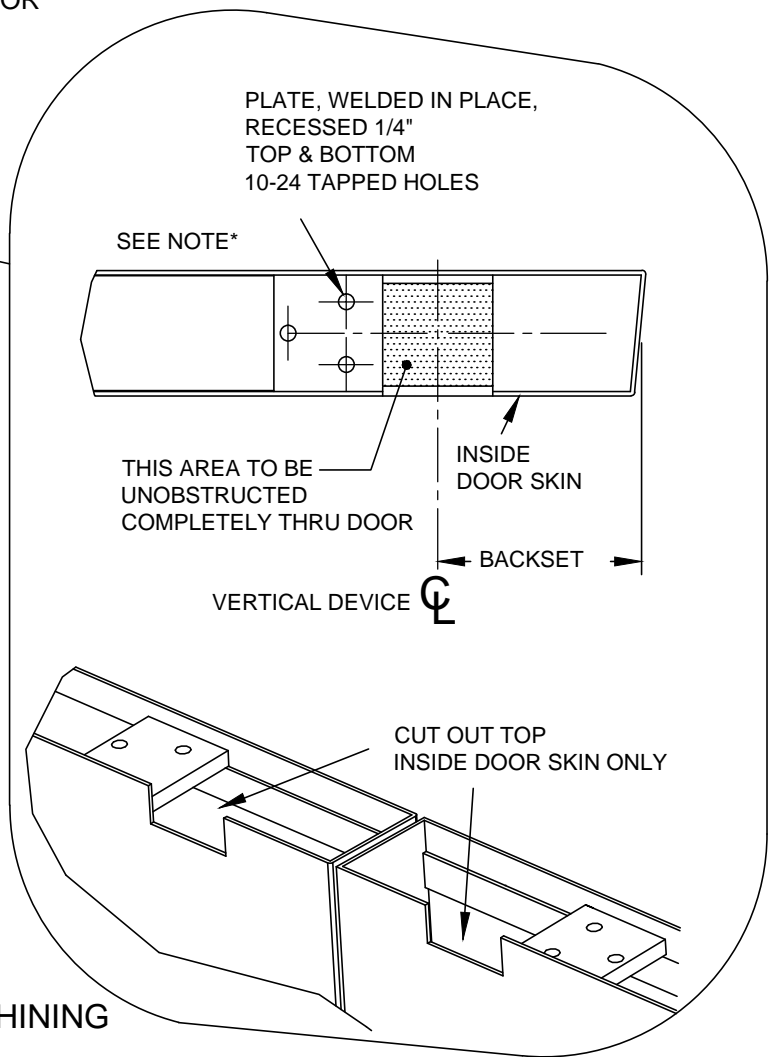
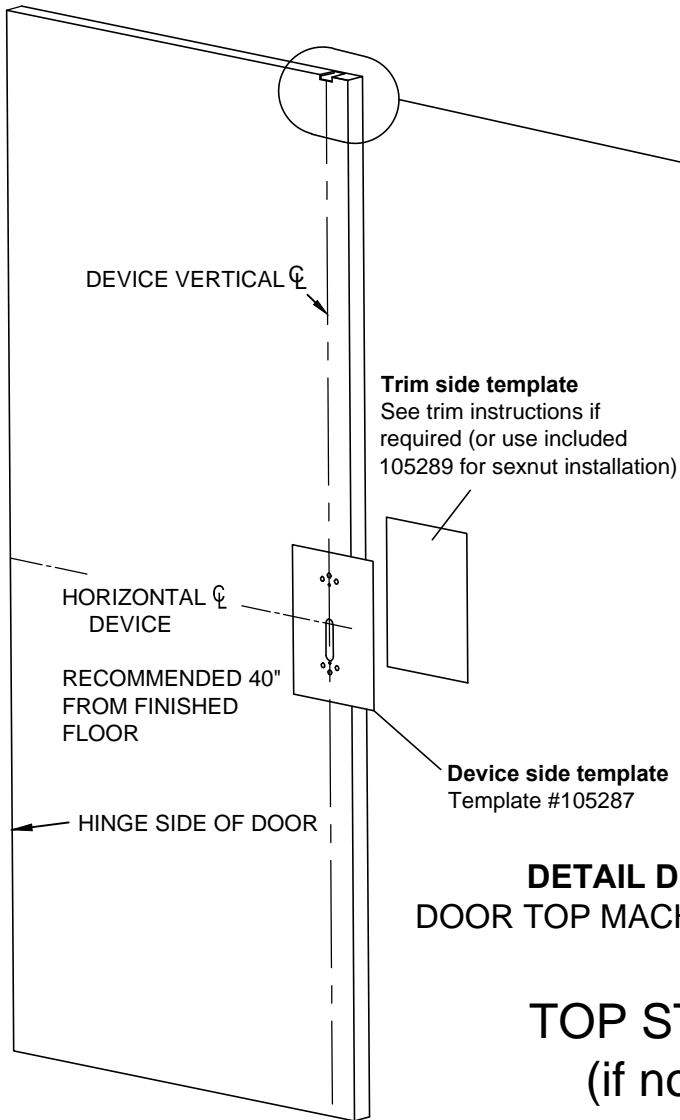

TOP STRIKE FRAME PREP (if not already prepped)

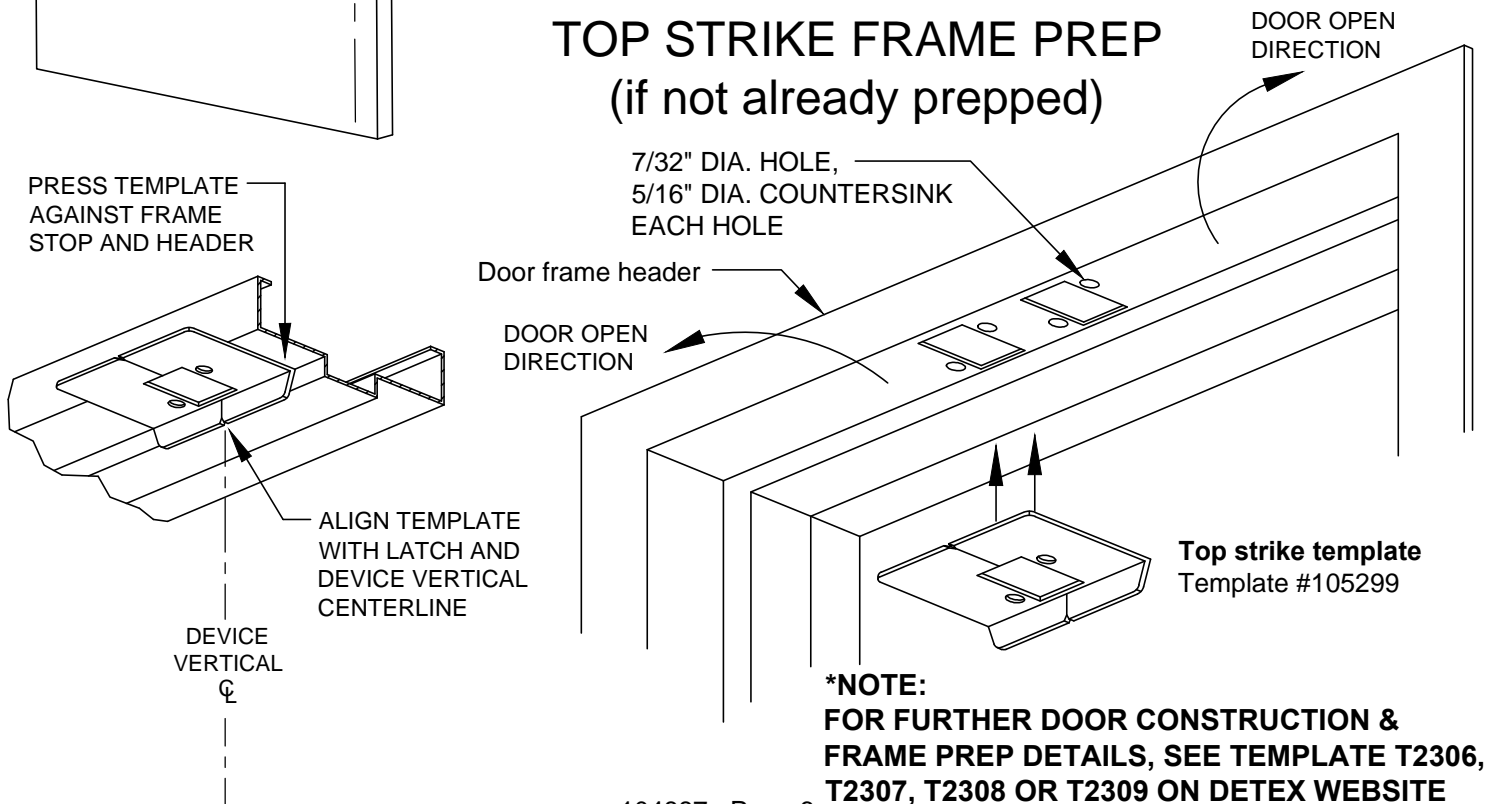

For 6'-8" (80") to 8'-0" (96") Door

STEP 3: TOP ROD ASSEMBLY & INITIAL ADJUSTMENT

3a. Align hole A in rod 104187 with hole in top latch as shown at right & tap the 13/16" long pin into latch hole.

3b. Measure **DIM B** as shown below.

3c. Use chart to determine pinning location of rods 104187 & 104172-1.

Round **DIM B** to nearest value in chart.

If more than 3/4" different from one of these chart values, drill a .189 (#12 drill bit) diameter hole

halfway between the 2 holes nearest to the measured **DIM B** and use this hole as pinning hole in next step.

3d. Insert 104172-1 rod into 104187 rod & line up appropriate pinning holes (from chart)

on both rods and tap in the 1/2" long pin to secure.

3e. Calculate **DIM D**:

(**DIM D** = measured **DIM B** minus 15 7/8")

Thread the assembled rods/latch into the centerlift mechanism assembly as shown at right until **DIM D** is achieved (within 1/16").

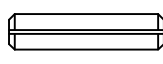
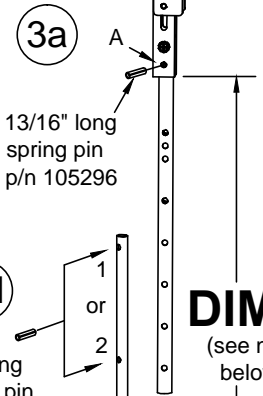

13/16" long spring pin
p/n 105296

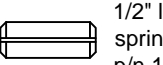
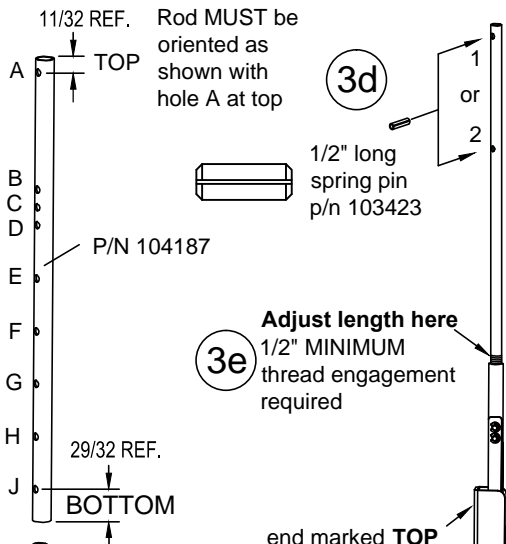

1/2" long spring pin
p/n 103423

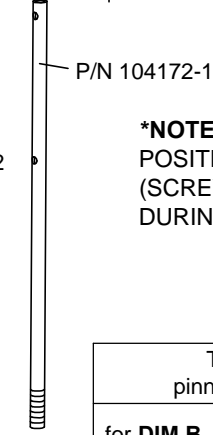
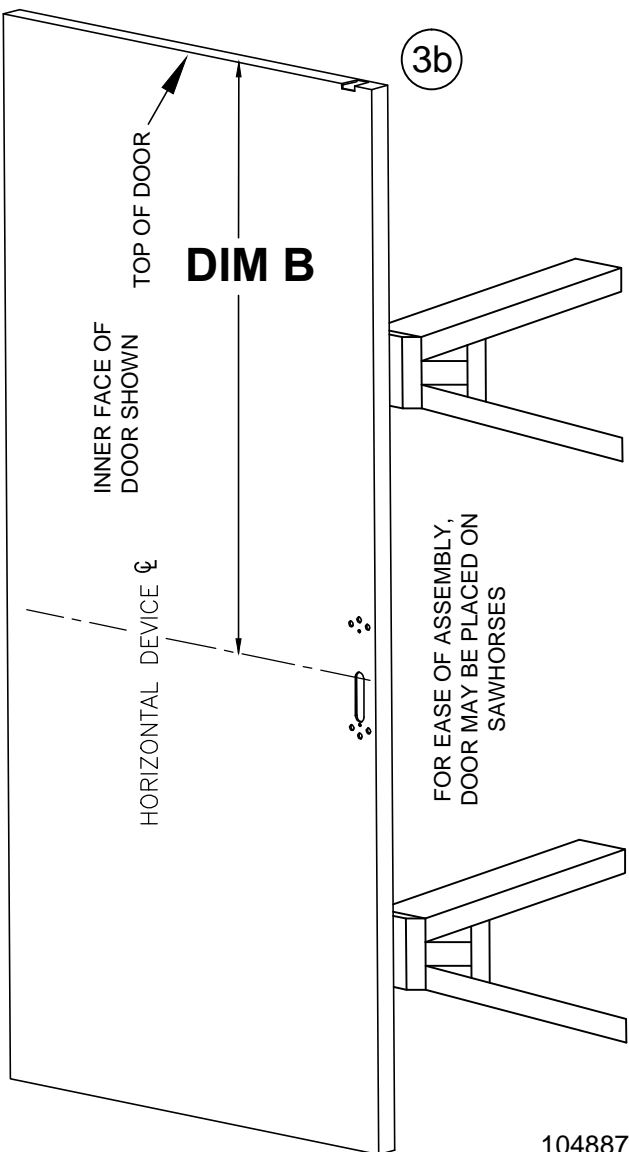

TOP ROD pinning locations		
for DIM B dimension of:	Align rod holes	
	Rod p/n 104172-1 HOLE	Rod p/n 104187 HOLE
39-7/8"	2	B
40-7/8"	2	C
41-7/8"	2	D
43-7/8"	1	B
44-7/8"	1	C
45-7/8"	1	D
47-7/8"	1	E
49-7/8"	1	F
51-7/8"	1	G
53-7/8"	1	H
55-7/8"	1	J

Note: If the combination of holes used is 2B or 2C, cut off approximately 2" from the UNTHREADED end of rod 104172-1

For 8'-1" (97") to 10' (120") Door

STEP 3: TOP ROD ASSEMBLY & INITIAL ADJUSTMENT

3a. Align hole A in rod 105097 with hole in top latch as shown at right & tap the 13/16" long pin into latch hole.

3b. Measure **DIM B** as shown below.

3c. Use chart to determine pinning location of rods 105097 & 104172-2.

Round **DIM B** to nearest value in chart.

If more than 3/4" different from one of these chart values, drill a .189 (#12 drill bit) diameter hole

halfway between the 2 holes nearest to the measured **DIM B** and use this hole as pinning hole in next step.

3d. Insert 104172-2 rod into 105097 rod & line up appropriate pinning holes (from chart) on both rods and tap in the 1/2" long pin to secure.

3e. Calculate **DIM D**:

(**DIM D** = measured **DIM B** minus 15 7/8")

Thread the assembled rods/latch into the centerlift mechanism assembly as shown at right until **DIM D** is achieved (within 1/16").

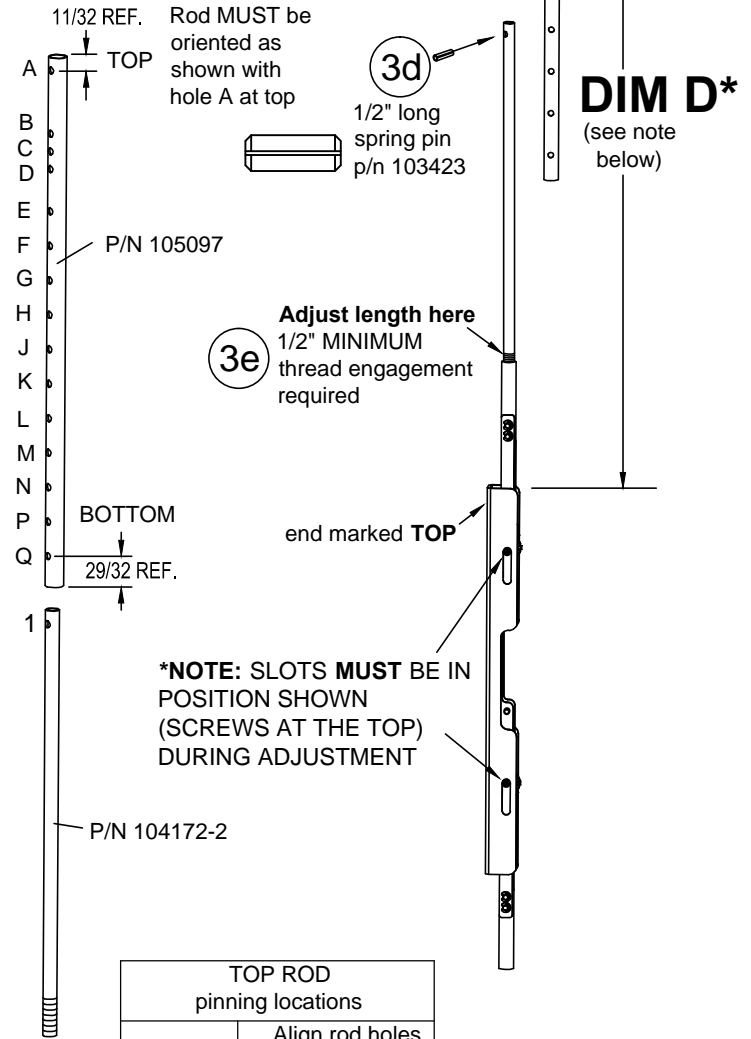
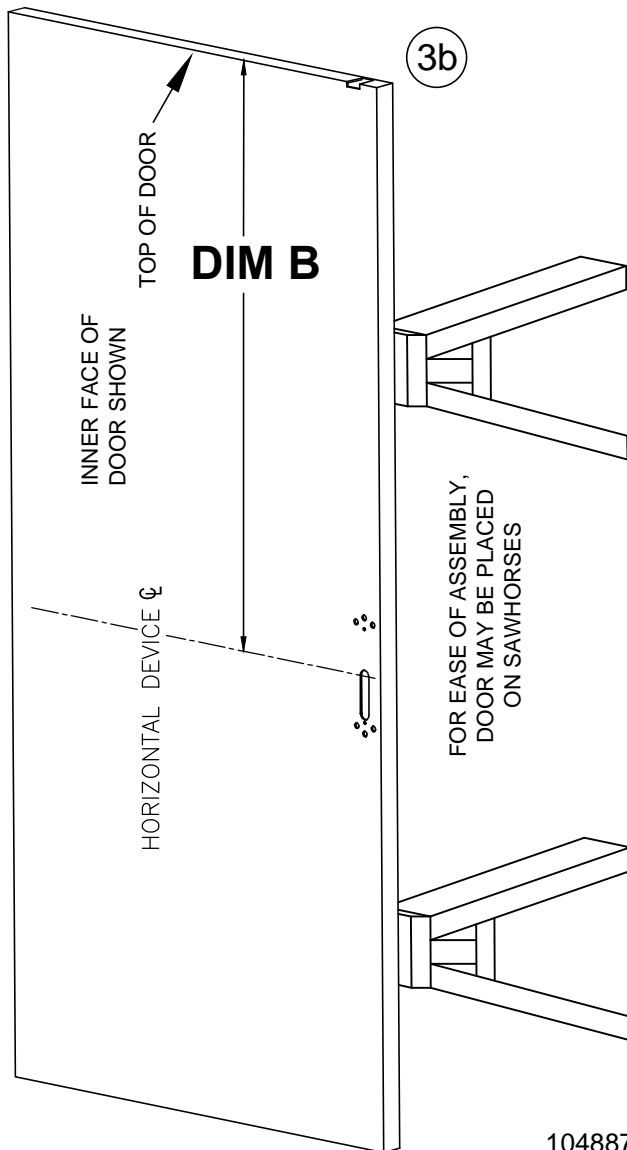

TOP ROD pinning locations		
for DIM B dimension of:	Align rod holes	
	Rod p/n 104172-2	Rod p/n 105097
	HOLE	HOLE
55-7/8"	1	B
56-7/8"	1	C
57-7/8"	1	D
59-7/8"	1	E
61-7/8"	1	F
63-7/8"	1	G
65-7/8"	1	H
67-7/8"	1	J
69-7/8"	1	K
71-7/8"	1	L
73-7/8"	1	M
75-7/8"	1	N
77-7/8"	1	P
79-7/8"	1	Q

STEP 4:

BOTTOM ROD / LATCH ASSEMBLY & ADJUSTMENT

(Disregard if TRO device is being installed)

4a. Using **DIM A** as measured in step 1, use chart to determine pinning location.

4a

Align rod holes with bottom latch (round **DIM A** to nearest value shown)

DIM A (device \bar{C} at distance from floor)	Bottom Rod p/n: 105098 use HOLE
38"	V
39"	W
40"	X
40-3/8"	Y
40-3/4"	Z

If **DIM A** is **less** than 37-1/4" from finished floor, a new pin hole must be drilled through 105098 rod. Subtract the centerline dimension from 38" and measure up this distance from hole V. Mark and drill .189 diameter hole (#12 drill).



ROD
P/N 105098

Note: If hole V or W is used (or if new hole is drilled closer to threaded end), trim off UNTHREADED end of rod as needed to allow rod to slide into bottom bolt far enough to pin.

4b. Remove clip 103551 and slide pin out. Place bottom rod 105098 into bolt, line up holes and replace pin and place clips into pin grooves.

4c. **DIM C** is the target length.

For no threshold or threshold 1/2" or less:

DIM C = measured DIM A minus 8".

For threshold greater than 1/2":

DIM C = measured DIM A minus 8" minus threshold height

The bottom bolt vertical travel from fully extended to fully retracted is approximately 9/16".

4d. Thread bottom rod into centerlift mechanism to achieve **DIM C** (within 1/16").

NOTE: SLOTS **MUST** BE IN POSITION SHOWN (SCREWS AT THE TOP) DURING ADJUSTMENT

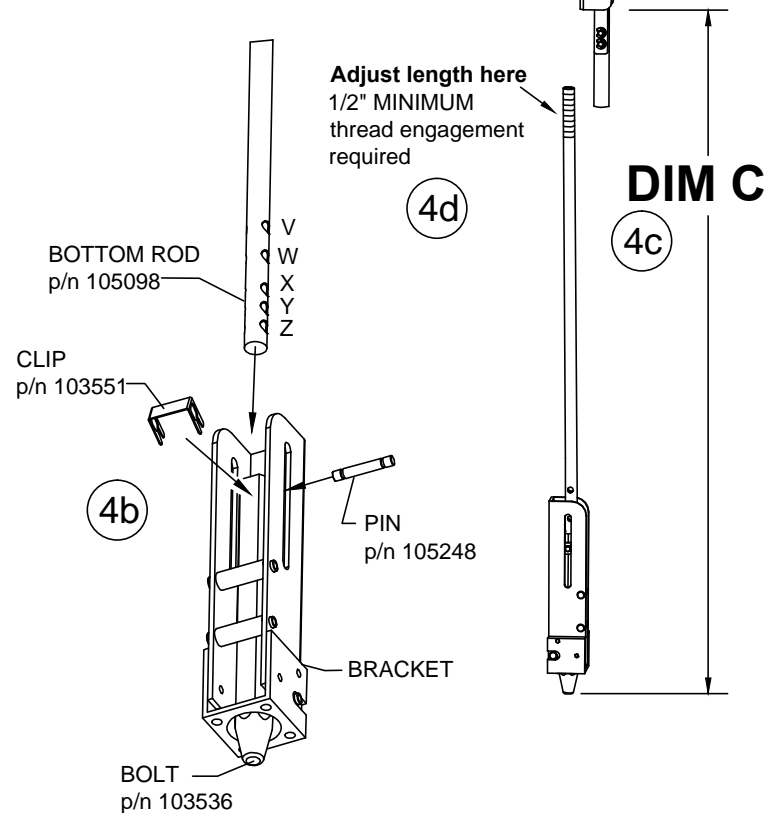
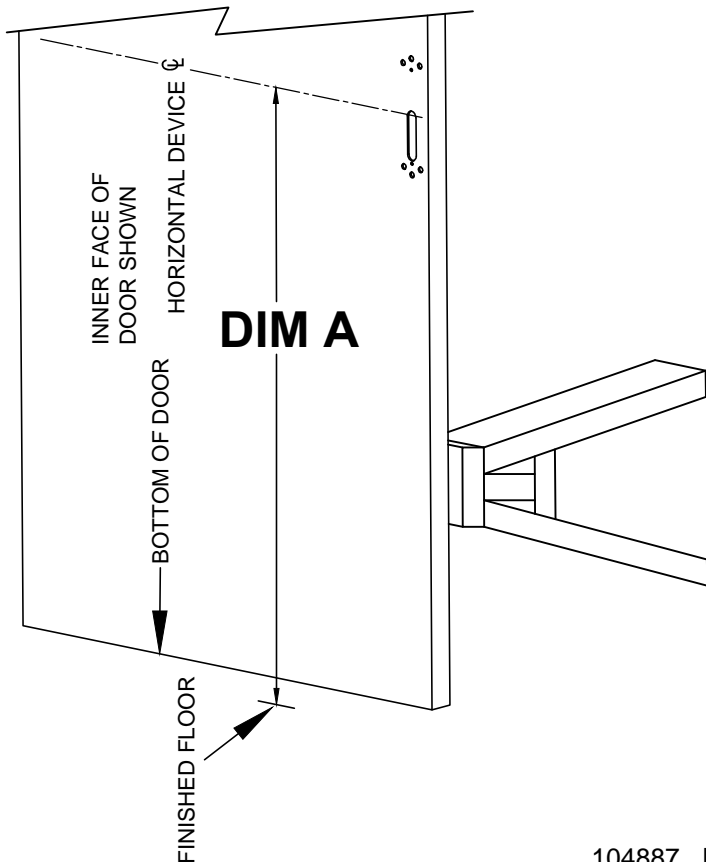

STEP 5: VISUAL ALIGNMENT CHECK:

- 5a. Lay internal latch components onto door for trial fit. Take care to protect door finish.
- 5b. Ensure top latch is in retracted position. Hold top rod in place and push top latch case towards device ϕ until latchbolt is fully retracted.
- 5c. Mounting holes for centerlift should line up with mounting holes in door, and top and bottom latches should be in position shown. If not, go back to steps 3 & 4 and verify rod length dimensions.

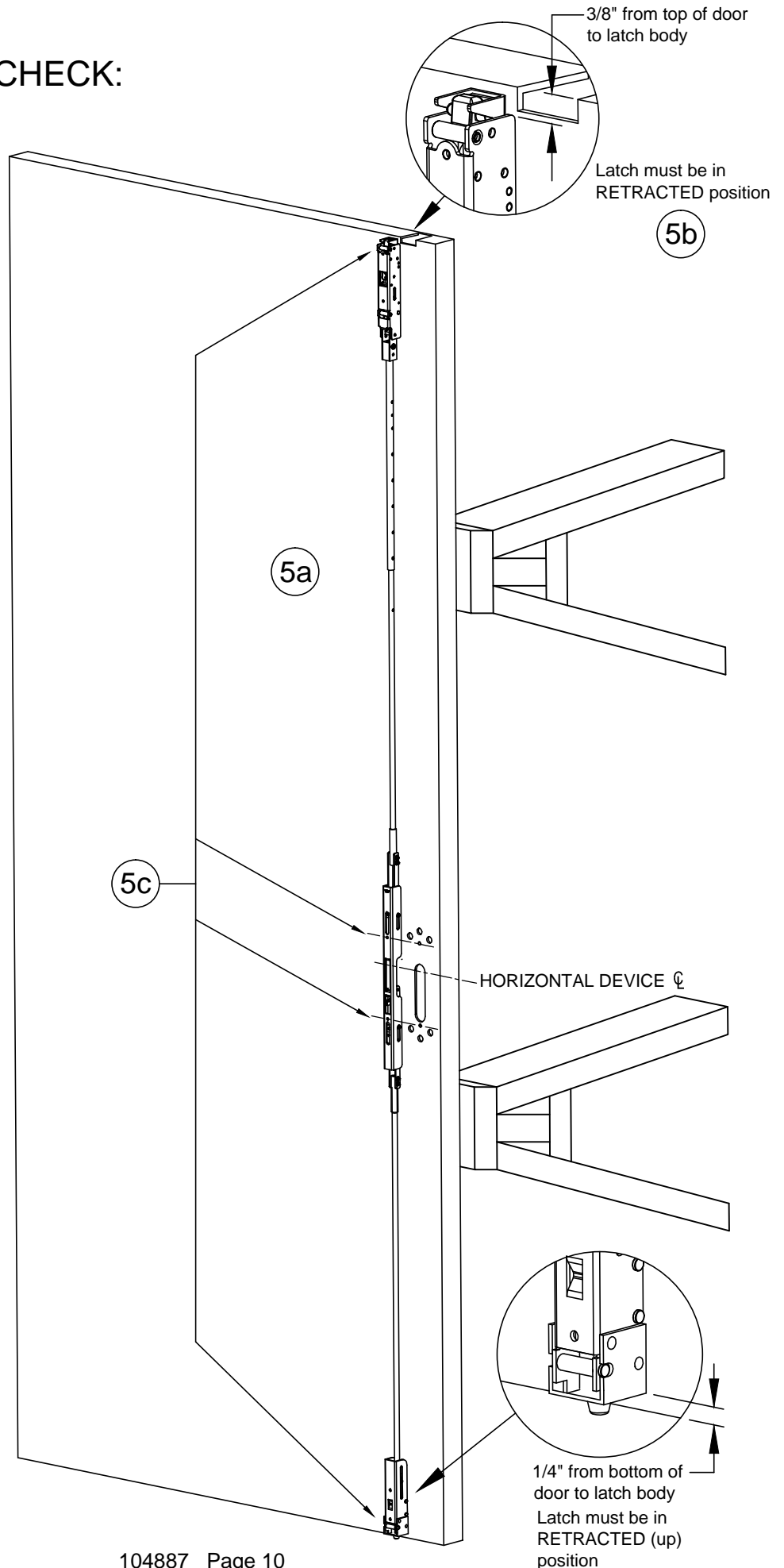

STEP 6:

ATTACH TOP LATCH MOUNTING BRACKETS

Attach top latch brackets as shown below. Three screws (10-24 x 5 /16" PFHUMS) required for each bracket.

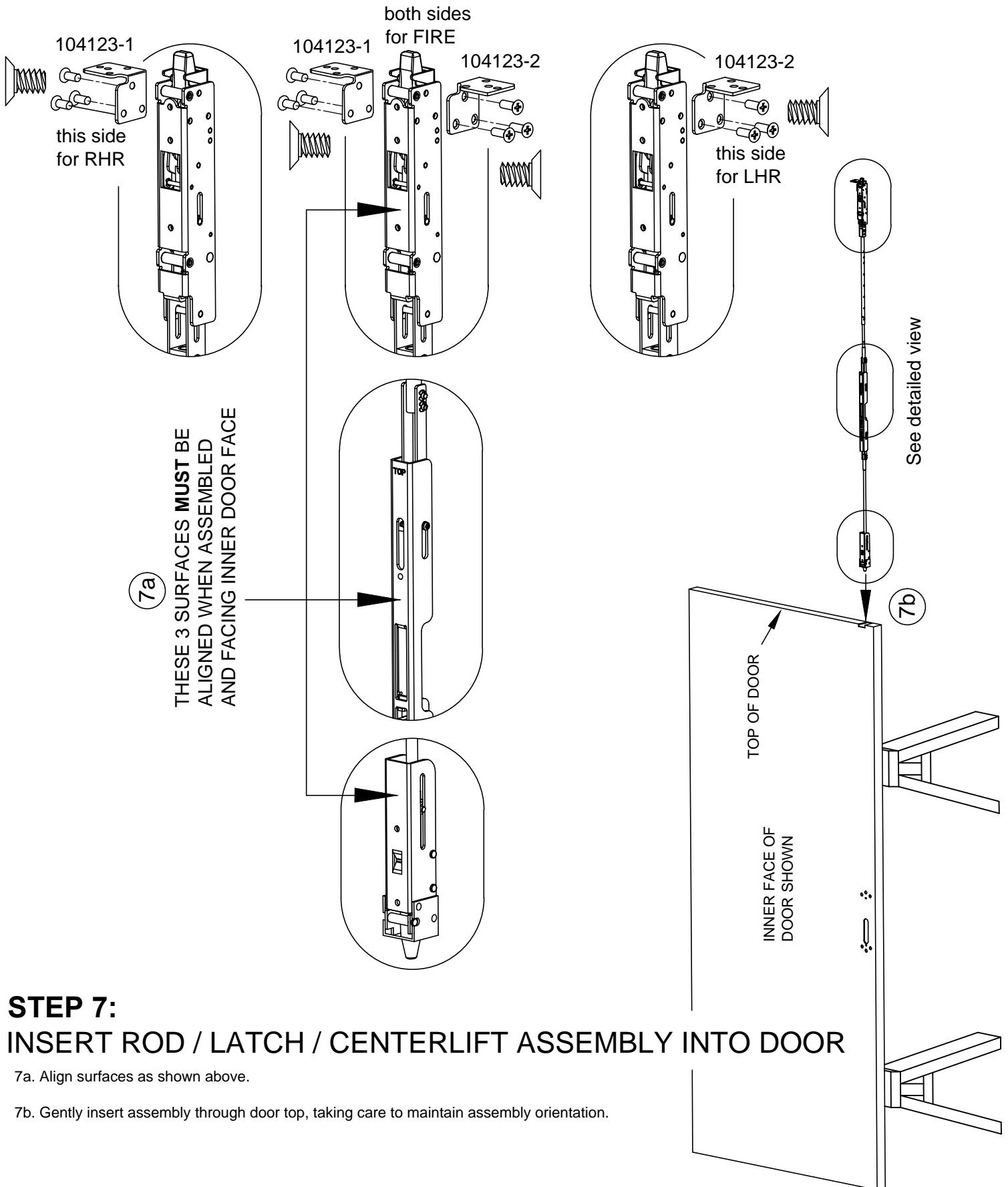

STEP 7:

INSERT ROD / LATCH / CENTERLIFT ASSEMBLY INTO DOOR

7a. Align surfaces as shown above.

7b. Gently insert assembly through door top, taking care to maintain assembly orientation.

STEP 8: SECURE ROD / LATCH / CENTERLIFT ASSEMBLY TO DOOR

8a. Attach top latch to door with three screws (six for fire rated doors).

(Disregard steps 8b & 8c if TRO device is being installed)

8b. Attach bottom mounting bracket to bottom latch with four screws.

8c. Attach bottom mounting bracket to door with three screws.

8d. Attach back plate to centerlift mechanism with two screws - DO NOT OVERTIGHTEN.

Assembly hint: Assemble one screw loosely without backplate, then add second screw through backplate. Remove first screw, align backplate and then re-install first screw.

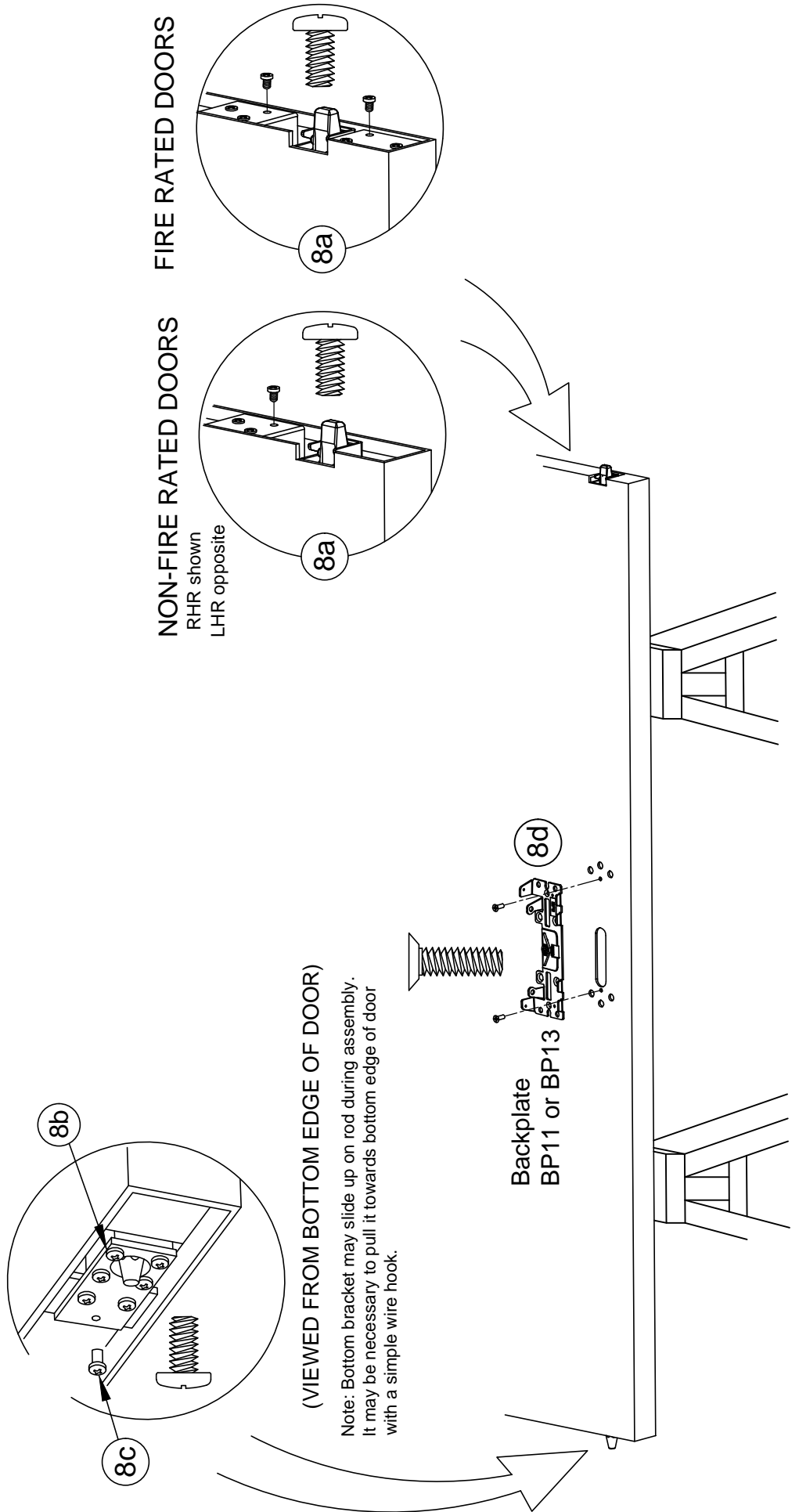

STEP 9: VERIFY CENTERLIFT MECHANISM OPERATION

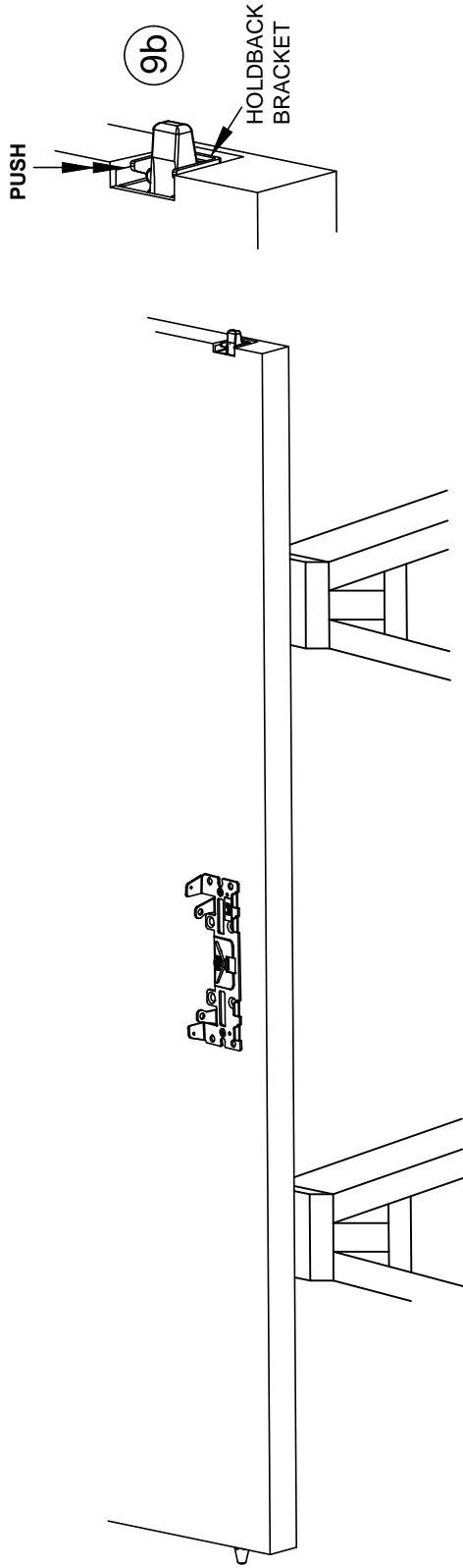

9a ACTIVATION SLOT LATCH EXTENDED POSITION

9b CORRECT POSITIONING OF ACTIVATION SLOT AND ADJUSTMENT SCREW IN LATCH EXTENDED POSITION

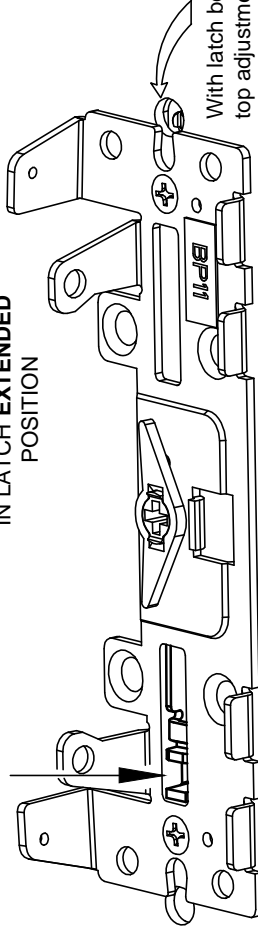

9a. Check current centerlift position using views shown.

9b. To extend latches, push and hold down on the holdback bracket to disengage the retraction feature, then use a screwdriver inserted into the activation slot to gently lower the slot to the extended position as shown.

9c. To retract latches, gently insert a screwdriver into the activation slot and raise the slot to the retracted position as shown.

TROUBLESHOOTING:

If latchbolt is fully extended while activation slot is not fully in the extended position, **then top rod is too short**. Go back to STEP 3 and correct.

If latchbolt is partially retracted while activation slot is fully in the extended position, **then top rod is too long**. In this case, latchbolt will be fully retracted before activation slot can travel fully to the retracted position. Go back to STEP 3 and correct.

9d. Bottom bolt drag check:

With top latch in retracted position, check to ensure that bottom bolt is not extending from bottom of door a distance greater than the bottom gap at finished floor (minus the threshold height if threshold is used). If it is, **then bottom rod is too long**. Go back to STEP 4 and correct.

9e. Upon completion, retract latches before proceeding to Step 10.

9c CORRECT POSITIONING OF ACTIVATION SLOT AND ADJUSTMENT SCREW IN LATCH RETRACTED POSITION

9a ACTIVATION SLOT LATCH RETRACTED POSITION

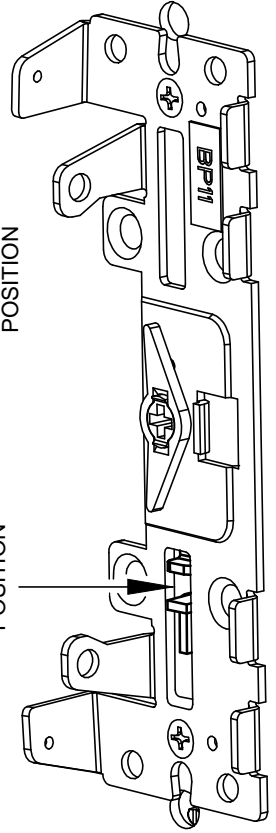

With latch bolt extended, top adjustment screw should be exposed. If not, go back to STEP 3 and make top rod longer.

STEP 10: HANG DOOR / ASSEMBLE DEVICE TO DOOR

10a INSTALL DOOR ONTO FRAME PER MANUFACTURER'S SPECIFICATIONS

10b Rehandling procedure if required

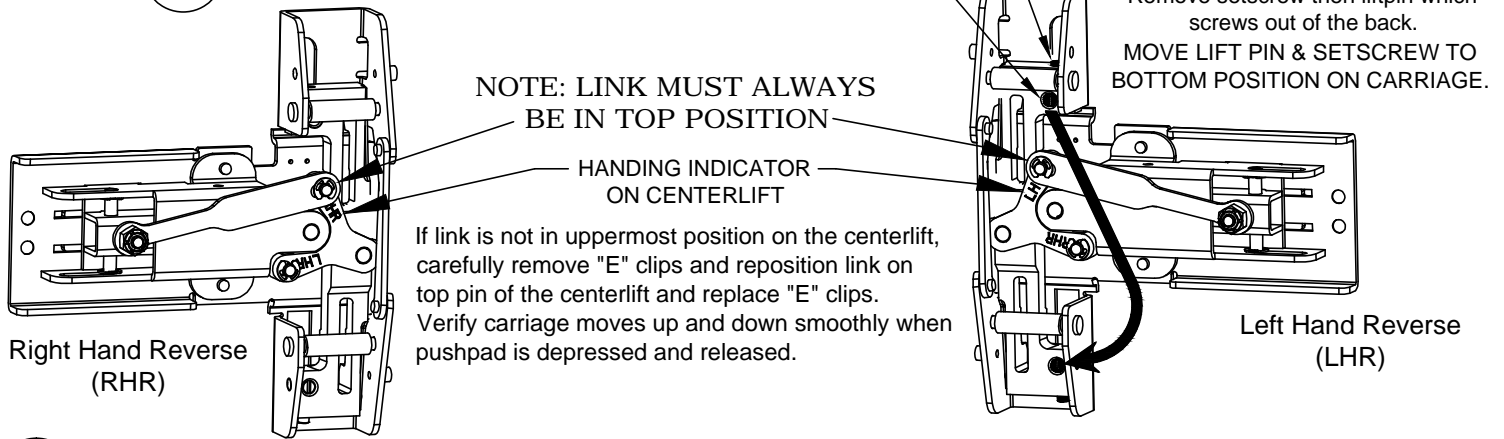

10c REFER TO TRIM INSTRUCTIONS AT THIS TIME, IF APPLICABLE

10d COMPLETE BACKPLATE MOUNTING

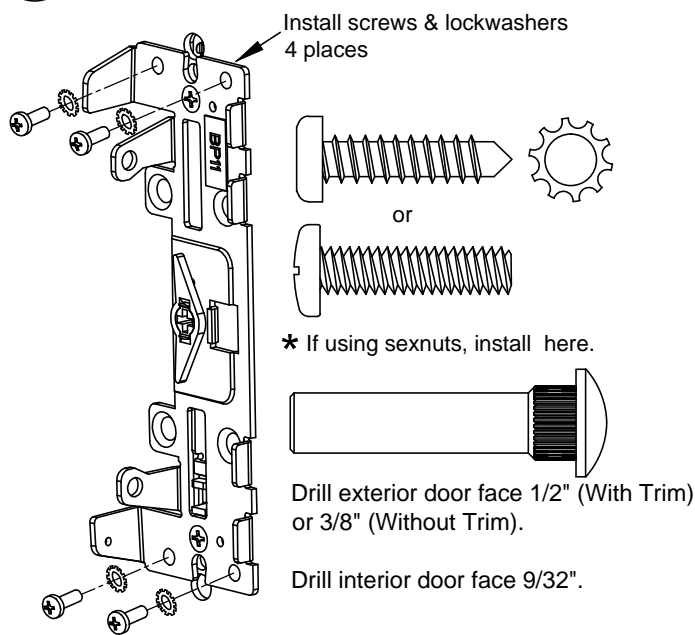

10e

INSTALL DEVICE TO BACKPLATE

Install device to backplate & fasten with 2 screws. Depress pushpad appropriate amount to line up lift pin with tabs.

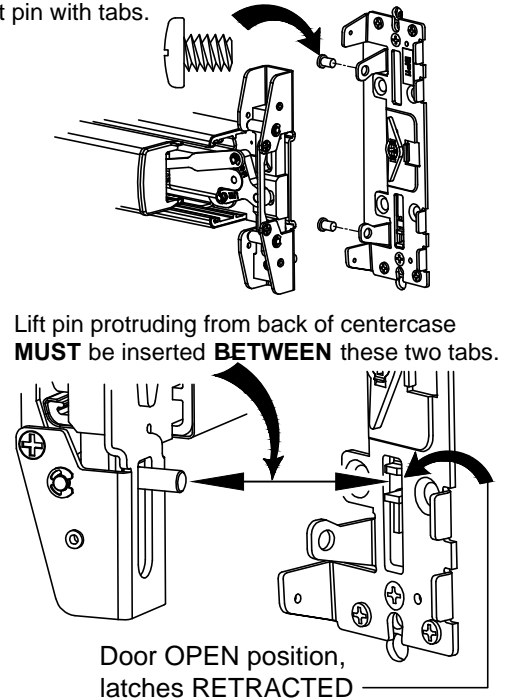

10f INSTALL ENDCAP BRACKET

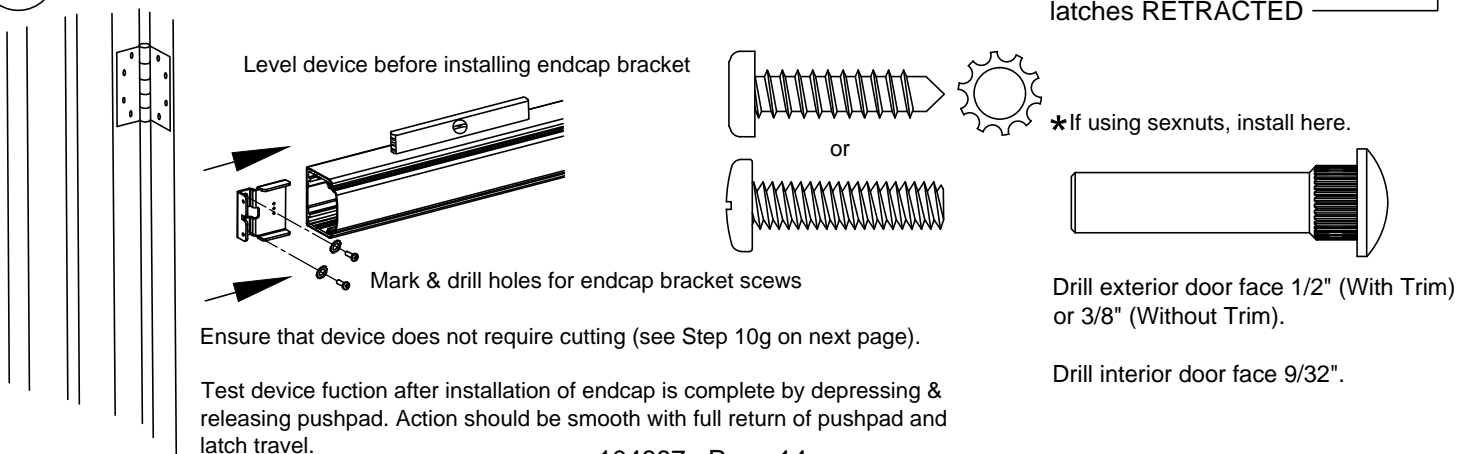

10g

CHECKING FOR DEVICE CLEARANCE (Cut-Off procedure if required)

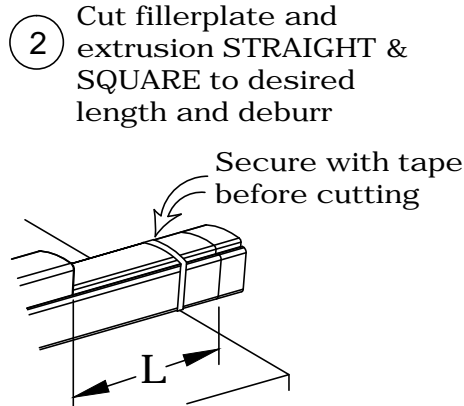
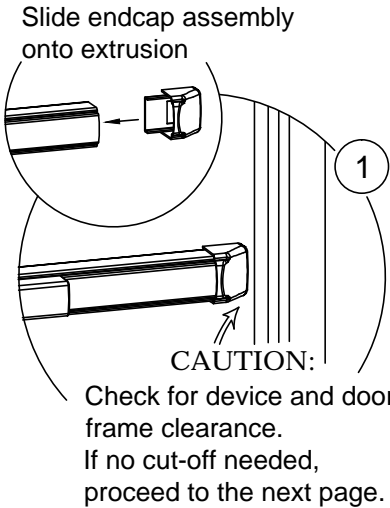

Minimum Fillerplate Length	
Type	Length (L)
LD	2-1/2"
HD/CD	3"

For aluminum Advantex finish cutdown applications:

After cutting, the baseplate extrusion can be reversed to place the cut end inside the head cover. To do so, loosen the setscrew inside the aluminum baseplate extrusion and slide extrusion out, reverse, & slide back in. Tighten setscrew.

10h

MORTISE CYLINDER INSTALLATION CD (Cylinder Dogging) Cylinder Installation

Cylinder nut socket
p/n 103779
(sold separately)

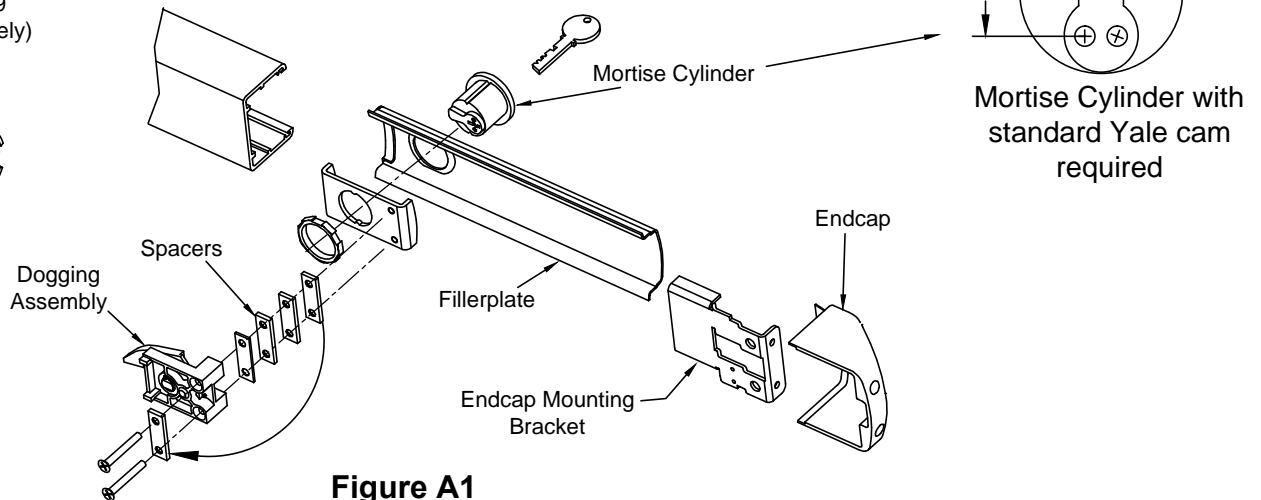

Figure A1

Follow steps "a" through "g" for CD installations

- Remove endcap and endcap mounting bracket.
- Remove fillerplate.
- Remove and discard shipping insert and nut. Loosen (2) screws from dogging assembly.
- Install mortise cylinder (sold separately) with large hex nut provided.
- Trial fit dogging assembly. If cylinder is too short, remove spacers as necessary and reattach them under the (2) screw heads. Fasten the (2) screws to the rest of the assembly.

NOTE: The key should easily turn in both directions.

- Rotate key counterclockwise
- Assembly complete. Continue with Panic Hardware instruction.

STEP 11: TOP STRIKE INSTALLATION

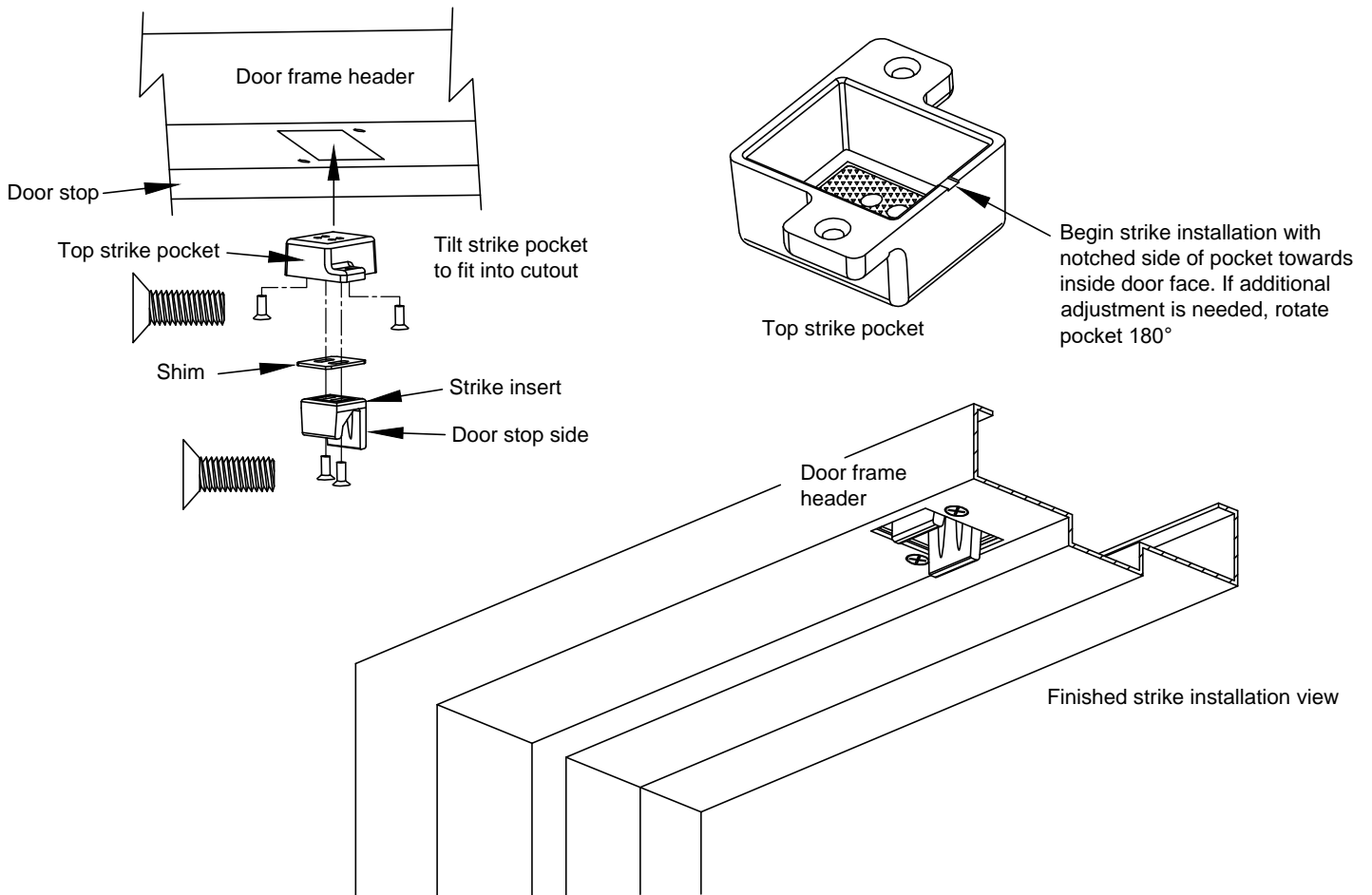

STEP 12: BOTTOM STRIKE INSTALLATION (Disregard if TRO device is being installed)

BOTTOM STRIKE HOLE LOCATION & DRILLING

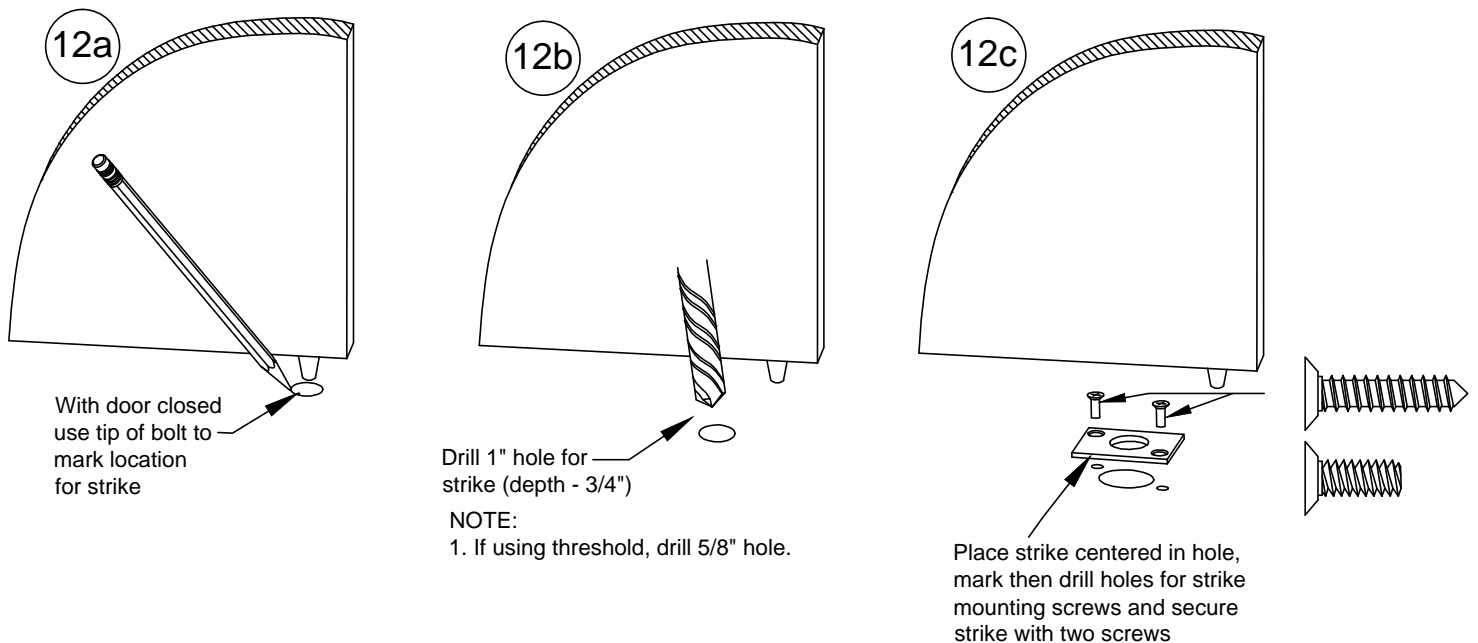

STEP 13: FINE LATCH ADJUSTMENT

13a. Ensure that latches are fully retracted. Gently close door. Latches should extend when door is closed.

13b. Depress pushpad and open door. Top latch should clear top strike & bottom bolt should not drag. Latches should remain in retracted position with pushpad released.

FINE LATCH ADJUSTMENT (if needed)

(± 3/8" adjustment possible on both top & bottom rods independently. See diagram below.)

13c. Top strike fine adjustment: Adjust strike engagement by either retaining or removing shim. Adjust door tightness by moving insert to desired position. Note that strike pocket can be flipped around to achieve additional adjustment (see step 11).

13d: **TOP LATCH ADJUSTMENT:** With latches extended, turn CCW until the top latchbolt projection begins to visually decrease, then turn CW until latchbolt projects fully. Rotate CW one additional full turn.

13d Top Adjustment

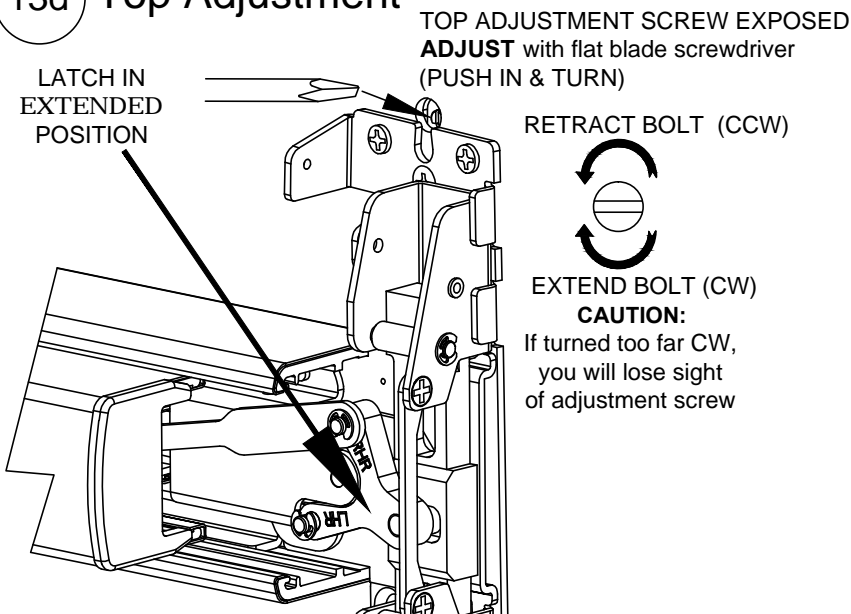

13e Bottom Adjustment

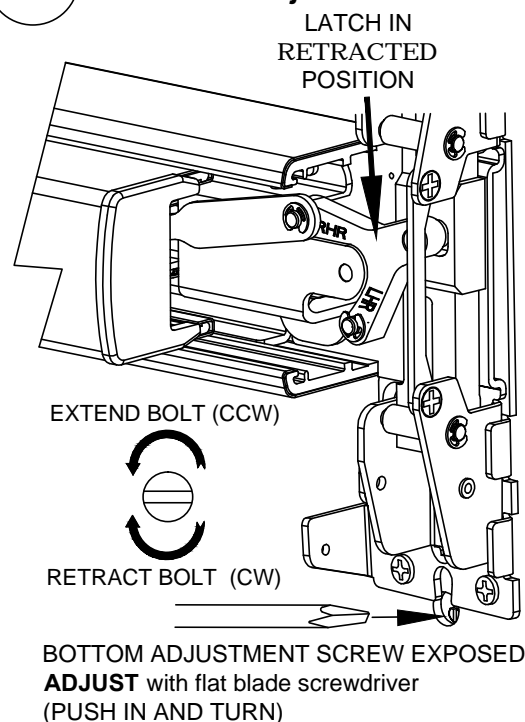

13e: **BOTTOM LATCH ADJUSTMENT:** With pushpad depressed (retracted position), extend or retract bottom bolt to desired engagement and clearance.

13f. Check device operation. Reference STEP 13a & 13b.

DEVICE OPERATION TROUBLESHOOTING

SYMPTOM	POSSIBLE CAUSE	SOLUTION
Device not latching when door closes	Bottom bolt is not properly aligned with bottom strike hole.	Modify bottom strike hole for fit.
	Top strike insert is not installed or not correctly aligned with the holdback.	Install and/or position strike insert per instructions.
	Through fasteners for trim (if applicable) are interfering with internal centerlift assembly.	Loosen and re-position through screws to clear.
	Rods improperly adjusted	Adjust rods per instructions. Remove device and re-install per instructions.
Latches release, but pushpad will not fully depress	Device centercase lift finger not inserted properly into centerlift assembly.	Remove device from backplate and re-install with lift finger correctly inserted.
	Top adjustment screw is adjusted too far in the retracted direction (CCW).	Rotate top adjustment screw in the extended direction (CW) per FINE LATCH ADJUSTMENT procedure.
Latches are not releasing when pushpad is fully depressed	Device centercase lift finger not inserted properly into centerlift assembly.	Remove device from backplate and re-install with lift finger correctly inserted.
	Top adjustment screw is adjusted too far in the extended direction (CW).	Rotate top adjustment screw in the retracted direction (CCW) per FINE LATCH ADJUSTMENT procedure.
	Bottom adjustment screw is adjusted too far in the extended direction (CCW).	Rotate bottom adjustment screw in the retracted direction (CW) per FINE LATCH ADJUSTMENT procedure.

STEP 14: COVER INSTALLATIONS

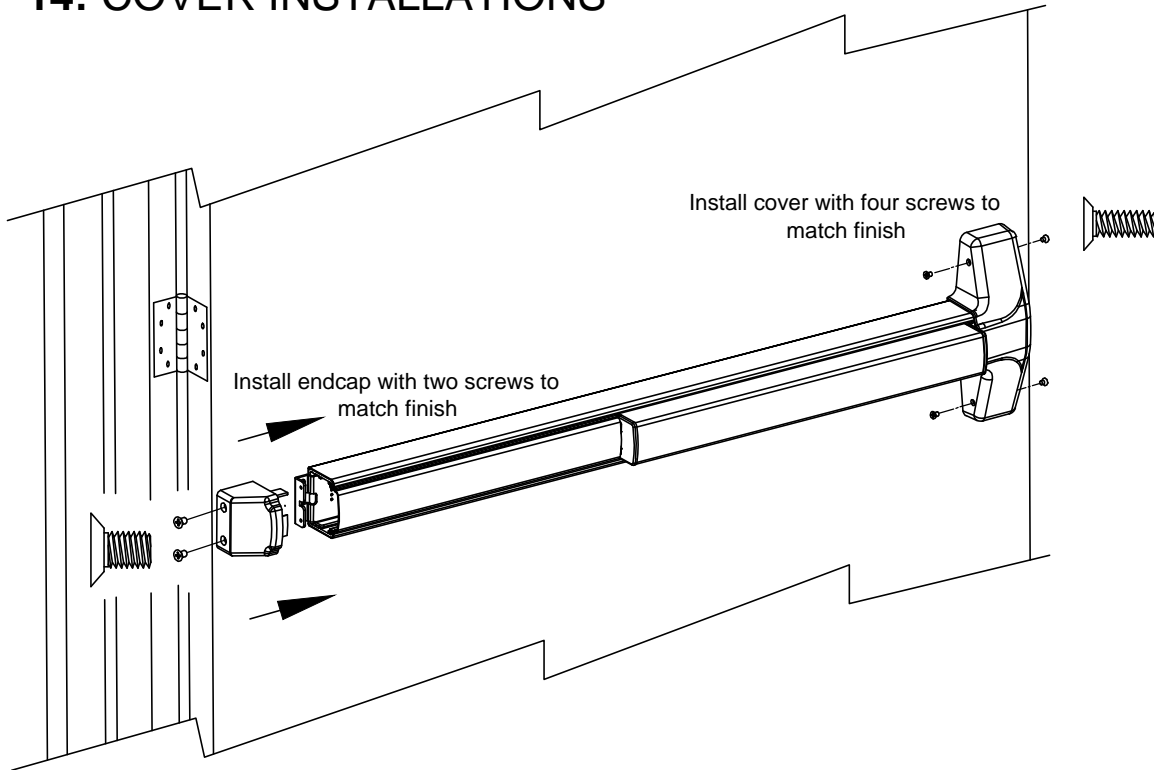

STEP 15: DOOR POPPER INSTALLATION

FIRE RATED TOP ROD ONLY (TRO) DOORS

A door locking popper is required when a fire door utilizes a top latching mechanism only (TRO). The popper is designed to project a spring loaded bolt into the adjacent frame or door in the event of fire. Detex recommends installing the popper in the edge of the door 12" above the threshold or finished floor.

Holes for the popper and plug must be aligned with each other.

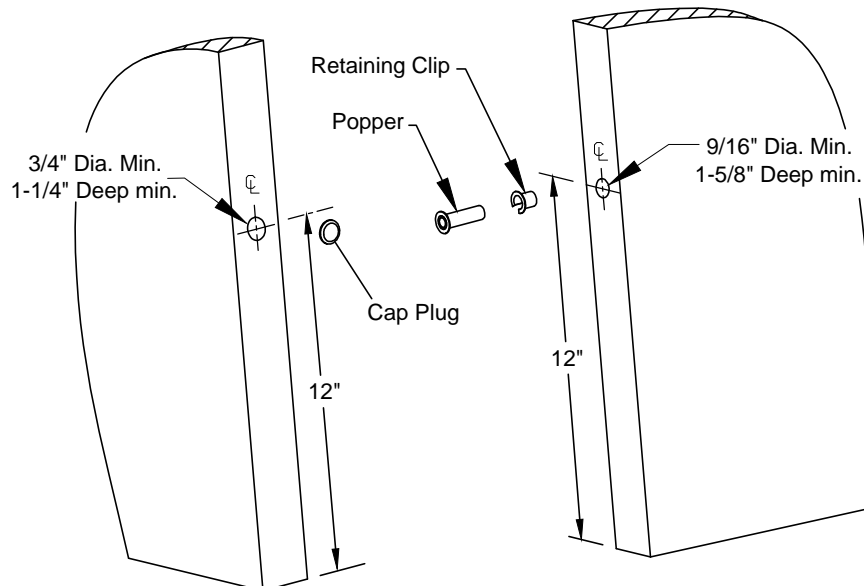

NOTE: Door/Frame reinforcement is required where popper and cap plug are to be installed.

Optional Accessories

Sex Nut Kits:

Catalog No. **SN3**

The #1/4-20 kits are available in 3 finishes:

Brushed Brass BHMA 606: p/n 105274-2

Stainless Steel BHMA 630: p/n 105274-9

Oil Rubbed Bronze BHMA 613: p/n 105274-25

SN3 uses screws in hardware kit

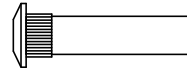

Tamper Kit

(Security Kit)

Catalog # & Part #:

SSK1

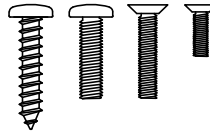

Security Screws

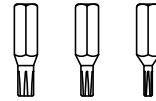

Security Pin TORX® Bits provided

Cylinder nut socket

p/n: 103779

