

Notes:

1. Do not scale drawing.
2. Dimensions are given in inches (mm).
3. Pivot drilled for 1/4-20 x 5/8" FHMS or #14 x 1-1/2 FHWS
4. Right hand shown.
5. Template drawing for reference only.

01-03

EM19
Side Jamb Pivot
3/4" Offset – Handed



An ASSA ABLOY Group Company

Franklin Park, IL 60131

NUMBER

ISEM19

DATE

4-07

Handed

EM19 Side Jamb Pivot Installation Instructions

3/4" Offset

IMPORTANT: Prepare door and frame per instructions on reverse side. Door must be hung before the pivot is installed. The EM-19 pivot cannot take the downward load (weight) of the door. The door weight must be carried by a floor closer, bottom pivot or additional M-19 or M-190 side jamb pivots.

ALIGNMENT: To insure proper installation, the centerline of the side jamb pivot must be in line with the centerline of the top and bottom pivot points. See illustration.

PIVOT INSTALLATION:

NOTE: Door and jamb portion of EM-19 are assembled in the factory. They cannot be separated and must be installed as assembled.

Open door and connect wires on the jamb portion to the wires in the frame. Push the wires back into the frame as the jamb portion is set into place in the frame mortise. Install the 5 jamb screws.

Connect the wires on the door portion to the door wires. Push the wires back into the door as the door portion is set into place in the door mortise. Install 5 door screws.

Test the electrical installation for proper operation of the wired door devices.

ELECTRICAL RATINGS:

Low voltage only
Current ratings each wire: 2 amp. continuous.

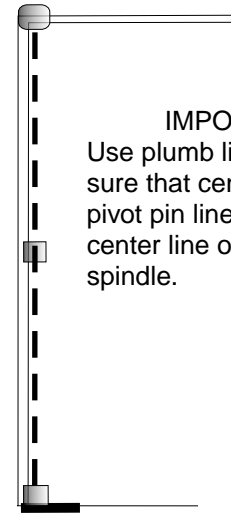

IMPORTANT:
Use plumb line to make sure that center line of top pivot pin lines up with center line of bottom spindle.

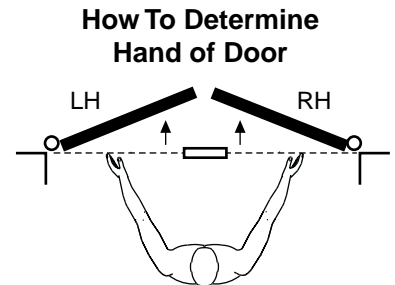
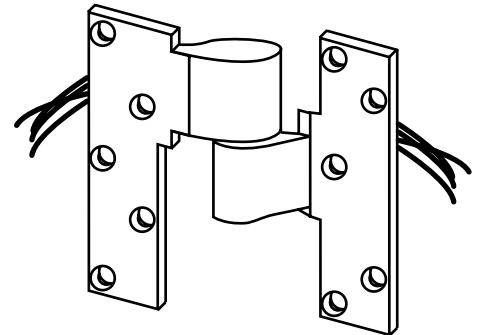

Face a door swinging open away from you. If it opens to the right, it is right hand. If it opens to the left, it is left hand.

01-03

**EM19
Side Jamb Pivot
3/4" Offset – Handed**

REXSON™	
An ASSA ABLOY Group Company	
Franklin Park, IL 60131	
NUMBER	DATE
ISEM19	4-07