

TECHNICAL Practice

TELECOM SOLUTIONS FOR THE 21ST CENTURY

E-40 Series
Compact Single Gang
Entry Phones with LED

November 4, 2011

Compact Entry Phones Available in Five Attractive Finishes



E-40-SS
"Brushed Stainless Steel"
(similar to brushed nickel) Shown with
optional VE-3x5 box (not included)



E-40-BN
"Oil Rubbed Bronze"
(satin dark brown powder
paint with fine copper metallic)



E-40-PB
"Polished Brass"
(with clear gloss powder
paint to prevent tarnishing)



E-40-WH
"Satin White"
(satin white powder paint)



E-40-BK
"Satin Black"
(fine texture satin black
powder paint)

The **E-40** Series entry phones are compact, weather and vandal resistant, telephone line powered speaker phones designed to provide two-way handsfree communication. The **E-40's** compact size allows it to be mounted in a standard single gang electrical box. The **E-40** is available in five different attractive finishes to match your door hardware, light fixtures, etc. Replacement **E-40** faceplates (**PNL40**) can be purchased separately and are available in all five standard finishes. The **E-40's** blue LED continually provides light for locating the push button in dark locations, dims to indicate off hook and flashes during incoming ring. **Note:** LED not available on all models. Contact Viking for more information. The **E-40** entry phones can share a single phone line with house or small business telephones when used with a Viking model **C-200**, **C-250** or **C-2000B** Entry Phone controller. The **E-40** entry phones can also be connected to an unused analog station port (programmed for ring down) on a phone system or connected directly to a telephone line when used with a Viking model **K-1900-5** or **K-1900-30** auto dialer. The **E-40** features microphone and speaker volume controls, selectable auto answer for monitoring and intelligent call progress detection for automatic hang-up when the call is completed. For outdoor installations where the unit is exposed to precipitation or condensation, the **E-40** Series is available with Enhanced Weather Protection (**EWP**). For more information on **EWP**, see **DOD# 859**.

Features

- **Compact size:** Front panel is the size of a typical single gang mid-size wall plate
- **Mounting:** Flush mounts in a single gang electrical box (2.25" deep x 2.00" wide x 2.84" tall minimum) or surface mounts in a Viking model **VE-3x5** (not included, see **DOD# 424**)
- **Available in 5 standard faceplate finishes:** Brushed Stainless Steel, Oil Rubbed Bronze, Polished Brass, Satin Black and Satin White
- **PNL-40 faceplates:** Replacement faceplates with matching screws available in all five standard finishes
- **Vandal Resistant Features:** 16 gauge polished brass or 18 gauge 304 stainless steel faceplate, 316 stainless steel push button, carbon fiber reinforced plastic speaker screen, scratch resistant powder coating, hex drive mounting screws
- **Weather Resistant Features:** Mylar speaker, faceplate gasket, mic and speaker gasket, internally sealed (IP67) push button switch, self draining mic mount and UV stable weather resistant powder coating (excluding **E-40-SS** 304 Stainless Steel faceplate)
- **E-40-EWP** is designed to meet IP66 Ingress Protection Rating (see **DOD# 859** for more information)
- Telephone line powered
- Microphone and speaker volume controls
- Programmable Intelligent call progress detection for automatic hang-up on CPC, silence, busy signal, or time out
- Selectable auto answer feature for monitoring
- Programmable VOX (mic/speaker) switching speed
- Blue LED helps locate push button, indicate ringing and off hook

Applications

- Door or gate communication, business delivery entrances
- Use with a Viking **C-200** or **C-250** to control an **E-40** on a single line
- Use with a Viking **C-2000B** to control 1 to 4 **E-40's** and door/gate control on a single phone line
- Provide unique front and back door chimes and paging when used with a Viking **SLP-1**, **SLP-4** and **C-2000B**
- Residential, commercial and industrial door security
- Use with a Viking **K-1900-5** or **K-1900-30** for automatic speed dialing on telephone lines or analog PABX/KSU station ports
- Use on any analog PABX station port with programmable ringdown capability

Specifications

Power: Telephone line powered. Minimum 18V DC talk battery voltage with a minimum loop current of 20mA. Loop current may be boosted on low current lines with a Viking model **TBB-1B** Talk Battery Booster (see **DOD# 632**).

Dimensions: Faceplate: 123.8mm x 79.4mm x 4.6mm (4.875" x 3.125" x 0.18"), Phone: 72mm x 46mm x 42mm (2.84" x 1.8" x 1.65")

Shipping Weight: 0.45 kg (1.0 lbs)

Operating Temperature: -34° C to 65° C (-30° F to 150° F)

Humidity: Standard model: 5% to 95% non-condensing humidity, EWP model: up to 100% humidity

Speaker Volume: Approximately 62db maximum @ 1m

Ring Voltage: 25V AC RMS minimum (for auto answer)

CPC Disconnect Time: 300ms minimum

REN: 0.8A

Connections: (2) gel-filled butt connectors

IF YOU HAVE A PROBLEM WITH A VIKING PRODUCT, PLEASE CONTACT: VIKING TECHNICAL SUPPORT AT (715) 386-8666

Our Technical Support Department is available for assistance Monday 8am - 4pm and Tuesday through Friday 8am - 5pm central time. So that we can give you better service, before you call please:

1. Know the model number, the serial number and what software version you have (see serial label).
2. Have your Technical Practice in front of you.
3. It is best if you are on site.

RETURNING PRODUCT FOR REPAIR

The following procedure is for equipment that needs repair:

1. Customer must contact Viking's Technical Support Department at 715-386-8666 to obtain a Return Authorization (RA) number. The customer MUST have a complete description of the problem, with all pertinent information regarding the defect, such as options set, conditions, symptoms, methods to duplicate problem, frequency of failure, etc.
2. Packing: Return equipment in original box or in proper packing so that damage will not occur while in transit. Static sensitive equipment such as a circuit board should be in an anti-static bag, sandwiched between foam and individually boxed. All equipment should be wrapped to avoid packing material lodging in or sticking to the equipment. Include ALL parts of the equipment. C.O.D. or freight collect shipments cannot be accepted. Ship cartons prepaid to:
Viking Electronics, 1531 Industrial Street, Hudson, WI 54016
3. Return shipping address: Be sure to include your return shipping address inside the box. We cannot ship to a PO Box.
4. RA number on carton: In large printing, write the R.A. number on the outside of each carton being returned.

RETURNING PRODUCT FOR EXCHANGE

The following procedure is for equipment that has failed out-of-box (within 10 days of purchase):

1. Customer must contact Viking's Technical Support at 715-386-8666 to determine possible causes for the problem. The customer MUST be able to step through recommended tests for diagnosis.
2. If the Technical Support Product Specialist determines that the equipment is defective based on the customer's input and troubleshooting, a Return Authorization (R.A.) number will be issued. This number is valid for fourteen (14) calendar days from the date of issue.
3. After obtaining the R.A. number, return the approved equipment to your distributor, referencing the R.A. number. Your distributor will then replace the product over the counter at no charge. The distributor will then return the product to Viking using the same R.A. number.
4. **The distributor will NOT exchange this product without first obtaining the R.A. number from you. If you haven't followed the steps listed in 1, 2 and 3, be aware that you will have to pay a restocking charge.**

FCC REQUIREMENTS

This equipment complies with Part 68 of the FCC rules and the requirements adopted by the ACTA. Inside the front panel of this equipment is a label that contains, among other information, a product identifier in the format US:AAAEQ#TXXXX. If requested, this number must be provided to the telephone company.

The REN is used to determine the number of devices that may be connected to a telephone line. Excessive REN's on a telephone line may result in the devices not ringing in response to an incoming call. In most but not all areas, the sum of the REN's should not exceed five (5.0). To be certain of the number of devices that may be connected to a line, as determined by the total REN's, contact the local telephone company. For products approved after July 23, 2001, the REN for this product is part of the product identifier that has the format US:AAAEQ#TXXXX. The digits represented by ## are the REN without a decimal point (e.g., 03 is a REN of 0.3). For earlier products, the REN is separately shown on the label.

The plug used to connect this equipment to the premises wiring and telephone network must comply with the applicable FCC Part 68 rules and requirements adopted by the ACTA. If your home has specially wired alarm equipment connected to the telephone line, ensure the installation of this E-40 does not disable your alarm equipment. If you have questions about what will disable alarm equipment, consult your telephone company or a qualified installer.

If the E-40 causes harm to the telephone network, the telephone company will notify you in advance that temporary discontinuance of service may be required. But if advance notice isn't practical, the telephone company will notify the customer as soon as possible. Also, you will be advised of your right to file a complaint with the FCC if you believe it is necessary.

The telephone company may make changes in its facilities, equipment, operations, or procedures that could affect the operation of the equipment. If this happens, the telephone company will provide advance notice in order for you to make

the necessary modifications to maintain uninterrupted service.

If trouble is experienced with the E-40, for repair or warranty information, please contact:

Viking Electronics, Inc., 1531 Industrial Street, Hudson, WI 54016 (715) 386-8666

If the equipment is causing harm to the telephone network, the telephone company may request that you disconnect the equipment until the problem is resolved.

Connection to Party Line Service is subject to State Tariffs. Contact the state public utility commission, public service commission or corporation commission for information.

WHEN PROGRAMMING EMERGENCY NUMBERS AND (OR) MAKING TEST CALLS TO EMERGENCY NUMBERS:

Remain on the line and briefly explain to the dispatcher the reason for the call. Perform such activities in the off-peak hours, such as early morning or late evenings.

It is recommended that the customer install an AC surge arrester in the AC outlet to which this device is connected. This is to avoid damaging the equipment caused by local lightning strikes and other electrical surges.

PART 15 LIMITATIONS

This equipment has been tested and found to comply with the limits for a Class A digital device, pursuant to Part 15 of the FCC Rules. These limits are designed to provide reasonable protection against harmful interference when the equipment is operated in a commercial environment. This equipment generates, uses, and can radiate radio frequency energy and, if not installed and used in accordance with the instruction manual, may cause harmful interference to radio communications. Operation of this equipment in a residential area is likely to cause harmful interference in which case the user will be required to correct the interference at his own expense.

Installation

The **E-40** is designed to be flush mounted into a standard single gang rough-in box with minimum inside dimensions of 2.25" deep x 2.00" wide x 2.84" tall. The **E-40** can also be surface mounted in a Viking model **VE-3x5** (not included, see **DOD# 424**).

WARNING: Do **NOT** use a typical "wet location box" as not all styles seal properly with the **E-40** faceplate.

A. New Construction Flush Mounting

Step 1. Front of box should stick out approximately 1/2" from front surface of wall stud (this may vary depending on the walls sheathing and siding thickness).

h-4 -7 i9(h-3.738 T7.583 spr 100 3ssurfacS .8r 4ypf.. l.44ng t8w [(A). onb)46e,o1 Tl

B. Old Work / Remodel Flush Mounting (Using an Allied Molded 9331 Rough-In Box)

C. Surface Mounting

A Viking model **VE-3x5** can be used to surface mount an **E-40** to a wall or post. Drill a small wire exit hole in wall. Pull wire through and seal hole around wire with putty or caulking. Route wire into the **VE-3x5** box, securely screw it to wall or post and seal hole in box around wire with putty or caulking. **Note:** Conduit may also be used when surface mounting wire, but should not enter through the top of the **VE-3x5**. When routing wiring from above, a drip loop is required. **WARNING:** Do **NOT** use a typical "wet location box" as not all styles seal properly with the **E-40** faceplate.

D. Mounting the Faceplate

After the Rough-In box or **VE-3x5** is securely mounted, caulking between the box and rough opening is completed (if required), and wires are connected, remove paper liner from face plate gasket. While firmly holding the LED light pipe in the faceplate, carefully slide the faceplate gasket over the back of the light pipe and press gasket to the back of the faceplate. Push the 1-1/4" 6-32 screws through faceplate holes and small holes in gasket, the faceplate gasket should retain the screws. Position Circuit board mounting plate over screws. Align screws with single gang box bosses and tighten face plate until gasket is fully collapsed and the push button is protruding through the clearance hole in the face plate. Included 1/4" thick gasket will provide an adequate seal for most siding surfaces; however for rough surfaces (ie: brick, stucco, etc.) additional caulking may be required.

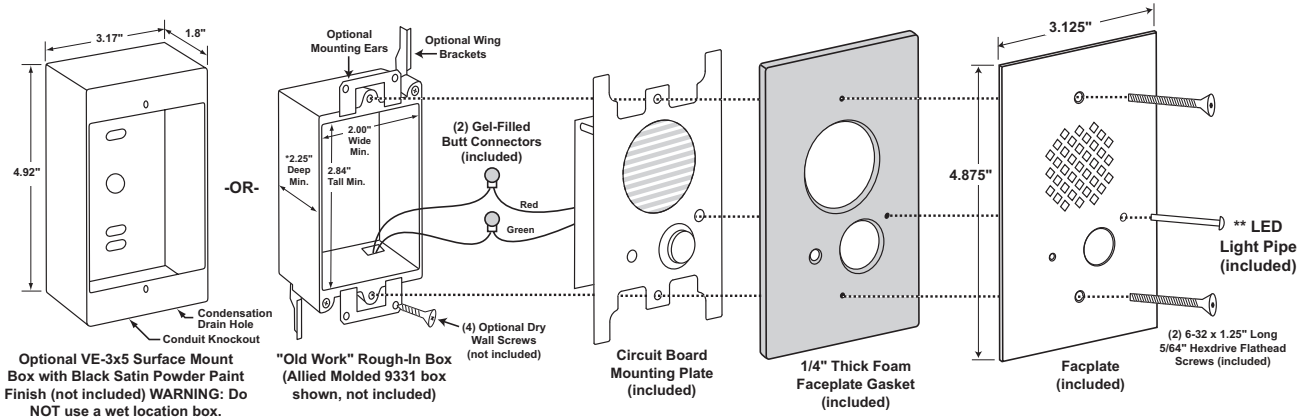

*** CAUTION:** Excessive wire length and/or using a rough-in box with inadequate depth can apply force to the circuit board causing physical damage.

**** Important:** Push LED light pipe into faceplate hole, then place faceplate upside down on a clean flat surface and push down on back side of plate until light pipe is fully seated and straight. **WARNING:** Inserting the light pipe more than one time can cause a loose fit.

E. Wiring the E-40

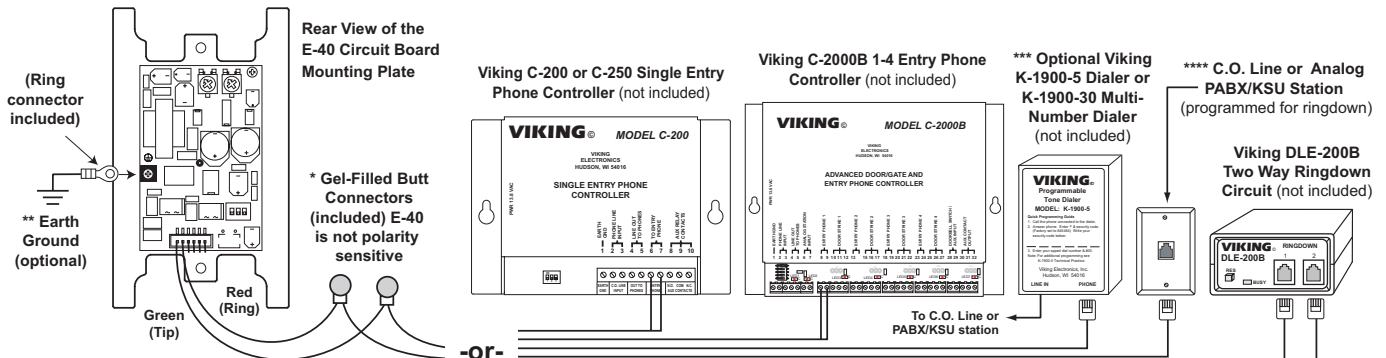

IMPORTANT: Electronic devices are susceptible to lightning and power station electrical surges from both the AC outlet and the telephone line. It is recommended that a surge protector be installed to protect against such surges.

To dedicated phone, unused trunk/line input of a phone system, or Viking C-1000B Doorbox Controller

*** Note:** The gel-filled (water-tight) butt connectors are designed for insulation displacement on 19-26 gauge wire with a maximum insulation of 0.082 inches. Do not strip wires prior to terminating.

**** Note:** To increase surge protection, loosen the PCB mounting screw labeled \oplus (as shown above) and fasten a wire with ring terminal (included) from the mounting screw to Earth Ground (grounding rod, water pipe, etc.) After fastening ring terminal to PCB mounting screw, bend terminal up to avoid interference with single gang box.

***** Note:** Talk battery must be a minimum of 28V DC when using the speaker phone with a Viking **K-1900-5 Dialer (DOD# 317)** or **K-1900-30 Multi-Number Dialer (DOD# 300)**.

****** Note:** When installing a line powered phone on a low voltage and/or low loop current phone system extension, a Viking **TBB-1B Talk Battery Booster** may be required, see **DOD# 632**.

Programming

A. Adjusting Speaker Volume

The speaker volume pot can be adjusted to increase or decrease the speaker volume to the level desired.

B. Adjusting the Microphone Volume

In certain noisy locations (background traffic, machinery or wind), the microphone volume may need to be decreased. A symptom of this is one-way talk path, in which the distant party cannot be heard over the speaker. A microphone volume pot is provided for increasing or decreasing the microphone volume. **Note:** If the microphone volume is set too high or too low, one-way talk path may occur.

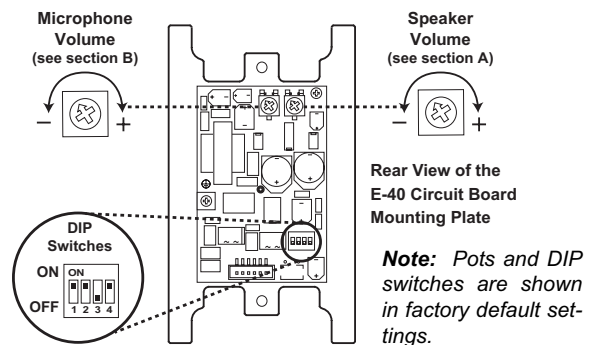

C. DIP Switch Programming

1. Auto Answer Feature ON/OFF (DIP Switch 1)

DIP switch 1 is for turning the Auto Answer feature ON and OFF. The E-40 is factory set to auto answer when an inbound call is detected.

2. Dial Tone Detection ON/OFF (DIP Switch 2)

With DIP switch 2 in the ON position, if the E-40 detects more than 5 seconds of continued dial tone, the unit will automatically disconnect. If the E-40 is installed on a continuously noisy line, it may detect the noise as dial tone and automatically disconnect. If this happens, turn the dial tone detection (DIP switch 2) OFF.

3. Programming Mode ON/OFF (DIP Switch 3)

With DIP switch 3 in the OFF position, the E-40 is in the "Normal Operation Mode" (factory setting). By placing DIP switch 3 in the ON position, the E-40's programming mode is enabled. The programming mode is used for adjusting the Call Length Time Out, Silence Time for automatic disconnect and the Talk/Listen delay (VOX switching speed). These features are set from the factory and normally do not need adjustment. If adjustment is necessary, see **Programming sections D - I**.

4. LED On/Off (DIP Switch 4)

With DIP switch 4 in the ON position, the blue faceplate LED will remain on at all times (to help locate push button switch in dark locations), dim to indicate off hook and flash to indicate incoming ring. When connecting an E-40 to a C.O.line, turn the LED off to comply with FCC regulations.

Switch	Position	Description
1	ON	Auto-Answer ON *
1	OFF	Auto-Answer OFF
2	ON	Dial Tone Detection ON *
2	OFF	Dial Tone Detection OFF
3	ON	Programming Mode
3	OFF	Normal Operation Mode *
4	ON	LED On *
4	OFF	LED Off

* **Note:** These are the factory settings.

D. Accessing the Programming Mode

The E-40 can be programmed from any Touch Tone phone using a telephone line, Viking model C-200, C-250 or C-2000B Entry Phone Controller, analog PABX/KSU station or a Viking model DLE-200B Line Simulator.

Step 1.	Move DIP switch 1 to the ON position (sets unit to answer incoming calls - see section C).
Step 2.	Move DIP switch 3 to ON (incoming calls automatically enter the programming mode - see section C).
Step 3.	From a Touch Tone phone call the line attached to the E-40.
Step 4.	When the E-40 answers, 2 beeps will be heard and you will automatically enter the programming mode.
Step 5.	When finished programming, enter "0000" to exit programming and move DIP switch 3 back to OFF (see section C).

E. Quick Programming Features

	Select Feature	Wait for Beep(s)	Enter Time Value	Wait for 2 Beeps
Call length time out (1-9 minutes), 10 = disabled (factory set to 11111 = 5 minutes)	0	beep	111...	beep beep
Silence time out for disconnect (10-90 seconds), 10 = disabled (factory set to 1111 = 40 secs)	00	beep	111...	beep beep
Talk/listen delay (VOX switching speed) 0.1 - 0.9 seconds (factory set to 111 = 0.3 secs)	000	beep	111...	beep beep
Forced hang-up command (used to exit programming and hang up the E-40)	0000	3 beeps		

F. Programming Beeps

See **Table A** below

If a valid "Feature" is entered, a single beep will be heard and you will have 20 seconds to enter a "Time" value. If an invalid "Feature" (five or more zeros) or forced hang-up command (four zeros) is entered, 3 beeps will be heard and the E-40 will hang up. If a valid "Time" is entered 2 beeps will be heard and you will have 20 seconds to enter your next "Feature". If an invalid "Talk/Listen Delay Time" is entered (10 or more ones), 3 beeps will be heard and you will have 20 seconds to enter your next "Feature".

G. Call Length Time Out

This feature selects the maximum length of time that calls can be connected. Programmable in increments of 1 minute up to a maximum of 9 minutes. To disable the call length time out, program ten ones in the "Time" value location. With the call length disabled, the E-40 phone must rely on CPC, busy, silence or return dial tone to hang-up. Use the chart at the right. * **Note:** The factory default is 5 minutes.

Table A

Time Value	Call Length Time Out	Silence Time Out	Talk/Listen Delay
1	1 min	10 sec	.1 sec
11	2 min	20 sec	.2 sec
111	3 min	30 sec	.3 sec*
1111	4 min	40 sec*	.4 sec
11111	5 min*	50 sec	.5 sec
111111	6 min	60 sec	.6 sec
1111111	7 min	70 sec	.7 sec
11111111	8 min	80 sec	.8 sec
111111111	9 min	90 sec	.9 sec
10 or more	Disabled	Disabled	Error

H. Silence Time Out

This feature selects the length of time that calls will remain connected without voice activity. Programmable in increments of 10 seconds up to a maximum of 90 seconds. To disable the silence time out, program ten ones in the "Time" value location. Use the chart at the right. * **Note:** The factory default is 40 seconds.

I. Talk/Listen Delay (VOX Switching Speed)

This feature selects switching time between talk/ listen modes (VOX switching time). Use the chart above. * **Note:** The factory default is .3 sec.

Operation

When the push button is pressed, the E-40 phone goes off-hook, much like a standard speaker phone. In the event that the line is busy, the E-40 will hang-up. The E-40 will also automatically hang up on CPC, silence, busy signal, return to dial tone or time out. If programmed to auto-answer (DIP switch 1 ON), the E-40 will also answer any incoming call.

Product Support Line...715.386.8666

Fax Back Line...715.386.4345

Due to the dynamic nature of the product design, the information contained in this document is subject to change without notice. Viking Electronics, and its affiliates and/or subsidiaries assume no responsibility for errors and omissions contained in this information. Revisions of this document or new editions of it may be issued to incorporate such changes.