

MOOG

VIDEOLARM

© 2011, Moog Videolarm, Inc. All Rights Reserved



MR7N

Indoor Recessed Ceiling Mount Dome Housing

www.videolarm.com

Installation and Operation Instructions for the following models:

- MR7CN Indoor 7" Recessed Ceiling housing, with network camera adapter brackets, clear dome
- MR7TN Indoor 7" Recessed Ceiling housing, with Network camera adapter brackets, tinted dome

Before attempting to connect or operate this product, please read these instructions completely.
To be used with the 81-IN5481 Instruction Manual.

W81-IN5323
01-13-2012

IMPORTANT SAFEGUARDS

- 1 Read these instructions.
- 2 Keep these instructions.
- 3 Heed all warnings
- 4 Follow all instructions.
- 5 Do not use this apparatus near water.
- 6 Clean only with damp cloth.
- 7 Do not block any of the ventilation openings. Install in accordance with the manufacturers instructions.
- 8 Cable Runs- All cable runs must be within permissible distance.
- 9 Mounting - This unit must be properly and securely mounted to a supporting structure capable of sustaining the weight of the unit.

Accordingly:

- a. The installation should be made by a qualified installer.
 - b. The installation should be in compliance with local codes.
 - c. Care should be exercised to select suitable hardware to install the unit, taking into account both the composition of the mounting surface and the weight of the unit.
- 10 Do not install near any heat sources such as radiators, heat registers, stoves, or other apparatus (including amplifiers) that produce heat.
 - 11 Do not defeat the safety purpose of the polarized or grounding-type plug. A polarized plug has two blades with one wider than the other. A grounding type plug has two blades and a third grounding prong. The wide blade or the third prong are provided for your safety. When the provided plug does not fit into your outlet, consult an electrician for replacement of the obsolete outlet.
 - 12 Protect the power cord from being walked on or pinched particularly at plugs, convenience receptacles, and the point where they exit from the apparatus.
 - 13 Only use attachment/ accessories specified by the manufacturer.
 - 14 Use only with a cart, stand, tripod, bracket, or table specified by the manufacturer, or sold with the apparatus. When a cart is used, use caution when moving the cart/ apparatus combination to avoid injury from tip-over.
 - 15 Unplug this apparatus during lighting storms or when unused for long periods of time.
 - 16 Refer all servicing to qualified service personnel. Servicing is required when the apparatus has been damaged in any way, such as power-supply cord or plug is damaged, liquid has been spilled or objects have fallen into the apparatus, the apparatus has been exposed to rain or moisture, does not operate normally, or has been dropped.

Be sure to periodically examine the unit and the supporting structure to make sure that the integrity of the installation is intact. Failure to comply with the foregoing could result in the unit separating from the support structure and falling, with resultant damages or injury to anyone or anything struck by the falling unit.

UNPACKING

Unpack carefully. Electronic components can be damaged if improperly handled or dropped. If an item appears to have been damaged in shipment, replace it properly in its carton and notify the shipper.

Be sure to save:

- 1 **The shipping carton and packaging material. They are the safest material in which to make future shipments of the equipment.**
- 2 **These Installation and Operating Instructions.**

SERVICE

If technical support or service is needed, contact us at the following number:

TECHNICAL SUPPORT
AVAILABLE 24 HOURS
1 - 800 - 554 -1124

SAFETY PRECAUTIONS

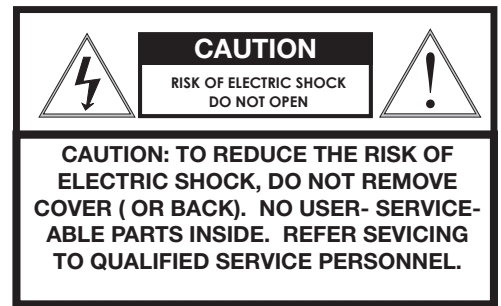

The lightning flash with an arrowhead symbol, within an equilateral triangle, is intended to alert the user to the presence of non-insulated "dangerous voltage" within the product's enclosure that may be of sufficient magnitude to constitute a risk to persons.

Este símbolo se piensa para alertar al usuario a la presencia del "voltaje peligroso no-aislado" dentro del recinto de los productos que puede ser un riesgo de choque eléctrico.

Ce symbole est prévu pour alerter l'utilisateur à la présence "de la tension dangereuse" non-isolée dans la clôture de produits qui peut être un risque de choc électrique.

Dieses Symbol soll den Benutzer zum Vorhandensein der nicht-Isolier "Gefährdungsspannung" innerhalb der Produkteinschließung alarmieren die eine Gefahr des elektrischen Schlages sein kann.

Este símbolo é pretendido alertar o usuário à presença "di tensão perigosa non-isolada" dentro do cerco dos produtos que pode ser um risco de choque elétrico.

Questo simbolo è inteso per avvertire l'utente alla presenza "di tensione pericolosa" non-isolata all'interno della recinzione dei prodotti che può essere un rischio di scossa elettrica.



The exclamation point within an equilateral triangle is intended to alert the user to presence of important operating and maintenance (servicing) instructions in the literature accompanying the appliance.

Este símbolo del punto del exclamation se piensa para alertar al usuario a la presencia de instrucciones importantes en la literatura que acompaña la aplicación.

Ce symbole de point d'exclamation est prévu pour alerter l'utilisateur à la présence des instructions importantes dans la littérature accompagnant l'appareil.

Dieses Ausruf Punktsymbol soll den Benutzer zum Vorhandensein de wichtigen Anweisungen in der Literatur alarmieren, die das Gerät begleitet.

Este símbolo do ponto do exclamation é pretendido alertar o usuário à presença de instruções importantes na literatura que acompanha o dispositivo.

Questo simbolo del punto del exclamation è inteso per avvertire l'utente alla presenza delle istruzioni importanti nella letteratura che accompagna l'apparecchio.



Limited Warranty for Moog Videolarm Products

Moog Videolarm warrants these products to be free from defects in material or workmanship as follows:

PRODUCT CATEGORY	PARTS \ LABOR
All Enclosures and Electronics*	Five (5) Years
Poles/PolEvators™/CamEvator	Three (3) Years
Warrior Series™/Q-View™/IR Illuminators	Five (5) Years
SView Series™	Five (5) Years **6 months if used in auto scan/tour operation
Controllers	Five (5) Years
Power Supplies	Five (5) Years
EcoKit	Three (3) Years
Accessory Brackets	Five (5) Years
Liberty Dome	Three (3) Years
*DeputyDome™, NiteTrac™, Igloo Dome, PurgeDome™	Three (3) Years **6 months if used in auto scan/tour operation

During the labor warranty period, to repair the Product, Purchaser will either return the defective product, freight prepaid, or deliver it to Moog Videolarm Inc. Decatur GA. The Product to be repaired is to be returned in either its original carton or a similar package affording an equal degree of protection with a RMA # (Return Materials Authorization number) displayed on the outer box or packing slip. To obtain a RMA# you must contact our Technical Support Team at 800.554.1124, extension 101. Moog Videolarm will return the repaired Product freight prepaid to Purchaser. Moog Videolarm is not obligated to provide Purchaser with a substitute unit during the warranty period or at any time. After the applicable warranty period, Purchaser must pay all labor and/or parts charges.

The limited warranty stated in these product instructions is subject to all of the following terms and conditions.

TERMS AND CONDITIONS

1. NOTIFICATION OF CLAIMS: WARRANTY SERVICE: If Purchaser believes that the Product is defective in material or workmanship, then written notice with an explanation of the claim shall be given promptly by Purchaser to Moog Videolarm. All claims for warranty service must be made within the warranty period. If after investigation Moog Videolarm determines the reported problem was not covered by the warranty, Purchaser shall pay Moog Videolarm for the cost of investigating the problem at its then prevailing per incident billable rate. No repair or replacement of any Product or part thereof shall extend the warranty period of the entire Product. The specific warranty on the repaired part only shall be in effect for a period of ninety (90) days following the repair or replacement of that part or the remaining period of the Product parts warranty, whichever is greater.

2. EXCLUSIVE REMEDY: ACCEPTANCE: Purchaser's exclusive remedy and Moog Videolarm's sole obligation is to supply (or pay for) all labor necessary to repair any Product found to be defective within the warranty period and to supply, at no extra charge, new or rebuilt replacements for defective parts.

3. EXCEPTIONS TO LIMITED WARRANTY: Moog Videolarm shall have no liability or obligation to Purchaser with respect to any Product requiring service during the warranty period which is subjected to any of the following: abuse, improper use, negligence, accident, lightning damage or other acts of God (i.e., hurricanes, earthquakes), modification, failure of the end-user to follow the directions outlined in the product instructions, failure of the end-user to follow the maintenance procedures recommended by the International Security Industry Organization, written in product instructions, or recommended in the service manual for the Product. Furthermore, Moog Videolarm shall have no liability where a schedule is specified for regular replacement or maintenance or cleaning of certain parts (based on usage) and the end-user has failed to follow such schedule; attempted repair by non-qualified personnel; operation of the Product outside of the published environmental and electrical parameters, or if such Product's original identification (trademark, serial number) markings have been defaced, altered, or removed. Moog Videolarm excludes from warranty coverage Products sold AS IS and/or WITH ALL FAULTS and excludes used Products which have not been sold by Moog Videolarm to the Purchaser. All software and accompanying documentation furnished with, or as part of the Product is furnished "AS IS" (i.e., without any warranty of any kind), except where expressly provided otherwise in any documentation or license agreement furnished with the Product. Any cost associated with removal of defective product and installation of replacement product is not included in this warranty.

4. PROOF OF PURCHASE: The Purchaser's dated bill of sale must be retained as evidence of the date of purchase and to establish warranty eligibility.

DISCLAIMER OF WARRANTY

EXCEPT FOR THE FOREGOING WARRANTIES, Moog Videolarm HEREBY DISCLAIMS AND EXCLUDES ALL OTHER WARRANTIES, EXPRESS OR IMPLIED, INCLUDING, BUT NOT LIMITED TO ANY AND/OR ALL IMPLIED WARRANTIES OF MERCHANTABILITY, FITNESS FOR A PARTICULAR PURPOSE AND/OR ANY WARRANTY WITH REGARD TO ANY CLAIM OF INFRINGEMENT THAT MAY BE PROVIDED IN SECTION 2-312(3) OF THE UNIFORM COMMERCIAL CODE AND/OR IN ANY OTHER COMPARABLE STATE STATUTE. Moog Videolarm HEREBY DISCLAIMS ANY REPRESENTATIONS OR WARRANTY THAT



Electrical Specifications

MR7TN



English

No power options provided.
Power required for camera only.
Power 24VAC
Class 2 Power Supply Only
Tools Required: Phillips Head Screwdriver
Ceiling Support Wires(18-24 Gauge Wire)



Español

Ningunas opciones de la energía proporcionaron. Energía requerida para la cámara fotográfica solamente.
Energía 24VAC
Fuente De Alimentación De la Clase 2 Solamente
Herramientas Requeridas: Destornillador Principal Phillips
Alambre De la Galga De la Ayuda Wires(18-24 Del Techo)



Français

Option de puissance n'a pas fourni.
Puissance requise pour l'appareil-photo seulement.
Puissance 24VAC
Alimentation D'Énergie De la Classe 2 Seulement.
Outils Requis : Tournevis Principal Phillips
Fil De Mesure De Soutien Wires (18-24 De Plafond)



Deutsch

Keine Energie Wahlen stellten zur Verfügung.
Energie erfordert für nur Kamera.
Energie 24VAC
Nur Kategorie 2 Spg.Versorgungsteil
Werkzeuge Erfordert:
Kreuzkopfhauptschraubenzieher
Decke Unterstützungswires
(18-24 Lehre Leitung)



Portuguese

Nenhumas opções do poder fornecidas.
Poder requerido para a câmara somente.
Poder 24VAC
Fonte De Alimentação Da Classe 2 Somente
Ferramentas Requeridas: Chave de fenda Principal Phillips
Fio Do Calibre Da Sustentação Wires(18-24 Do Teto)



Italiano

Nessun'opzione di alimentazione ha fornito.
Alimentazione richiesta per la macchina fotografica soltanto.
Alimentazione 24VAC
Gruppo di alimentazione Del Codice categoria 2 Soltanto
Gli Attrezzi Hanno richiesto: Cacciavite Capo "phillips"
Legare Del Calibro Di Sostegno Wires(18-24 Del Soffitto)

Content of Box

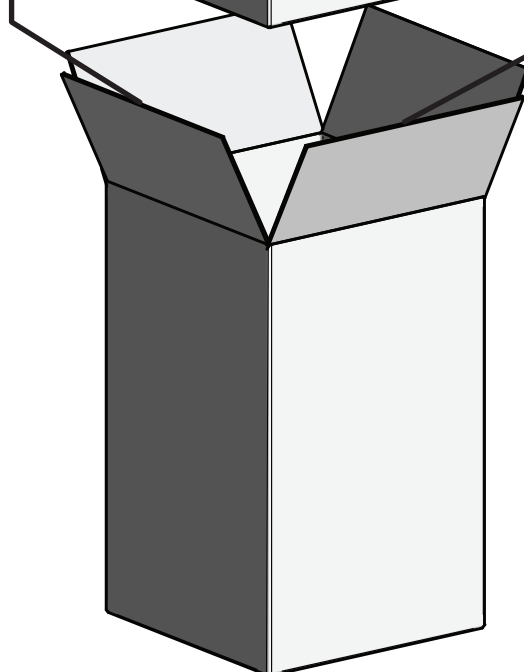
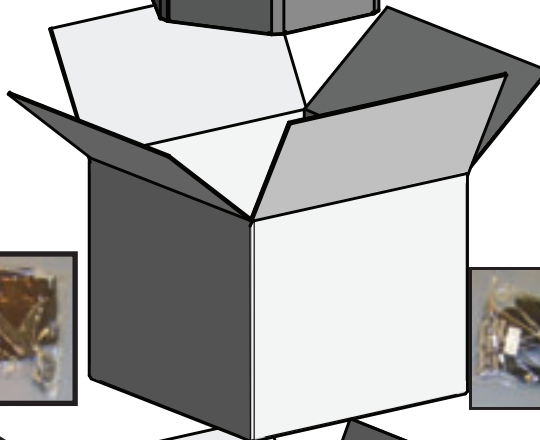
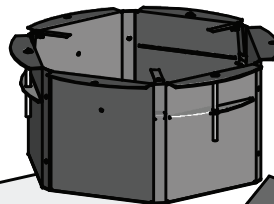
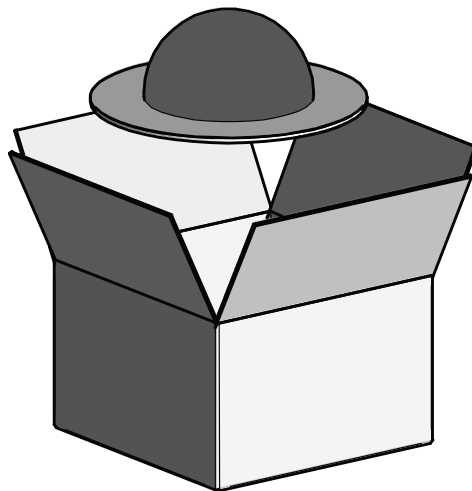

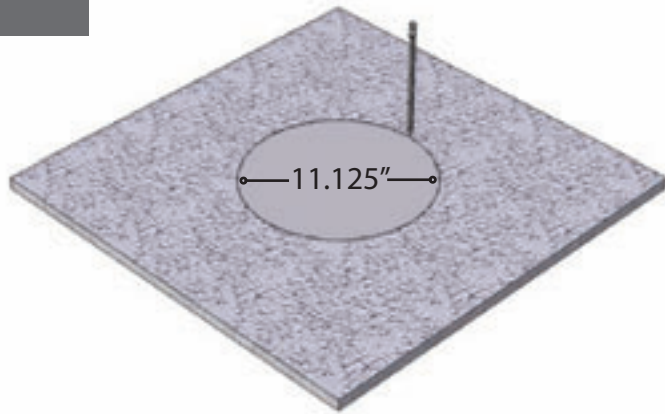

Using the provided template, mark the ceiling tile for the cutout.

- Con la plantilla proporcionada, cortar el azulejo del techo para el agujero.
- En utilisant le calibre fourni, marquez la tuile de plafond pour le coupe-circuit.
- Mit der zur Verfügung gestellten Schablone kennzeichnen Sie die Decke Fliese für den Ausschnitt.
- Usando o molde fornecido, marque a telha do teto para o entalhe.
- Usando la mascherina fornita, contrassegni le mattonelle del soffitto per il ritaglio.

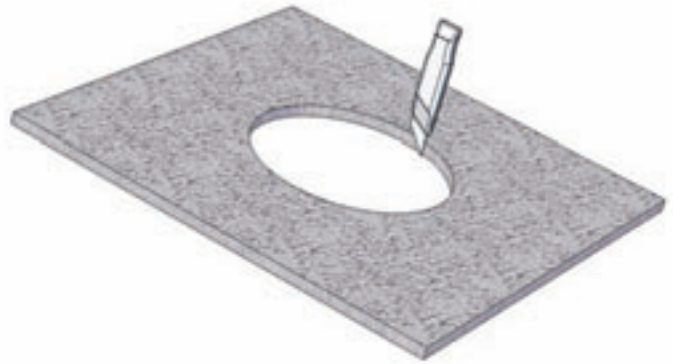

A box cutter or jigsaw can be used for cutting the circle.

- Un cortador o un rompecabezas de la caja se puede utilizar para cortar el círculo.
- Un coupeur ou une scie sauteuse de boîte peut être utilisé pour couper le cercle.
- Ein Kastenscherblock oder -tischlerbandsäge können für den Schnitt des Kreises benutzt werden.
- Um cortador ou um jigsaw da caixa podem ser usados cortando o círculo.
- Una taglierina o un jigsaw della scatola può essere utilizzato per il taglio del cerchio.



The camera may be mounted on either side of the tilted part of the camera bracket.

- La cámara fotográfica se puede montar de cualquier lado de la pieza inclinada del soporte de la cámara fotográfica.
- L'appareil-photo peut être monté de chaque côté de la pièce inclinée de la parenthèse d'appareil-photo.
- Die Kamera kann vom gekippten Teil des Kamerahaltewinkels auf beiden Seiten angebracht werden.
- A câmera pode ser montada em um ou outro lado da peça inclinada do suporte da câmera.
- La macchina fotografica può essere montata da qualsiasi lato della parte inclinata della staffa della macchina fotografica.

5

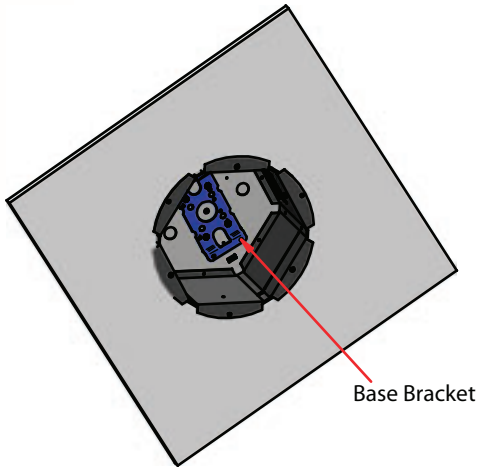

The camera may be mounted on either side of the tilted part of the camera bracket.

- La cámara fotográfica se puede montar de cualquier lado de la pieza inclinada del soporte de la cámara fotográfica.
- L'appareil-photo peut être monté de chaque côté de la pièce inclinée de la parenthèse d'appareil-photo.
- Die Kamera kann vom gekippten Teil des Kamerahaltewinkels auf beiden Seiten angebracht werden.
- A câmera pode ser montada em um ou outro lado da peça inclinada do suporte da câmara.
- La macchina fotografica può essere montata da qualsiasi lato della parte inclinata della staffa della macchina fotografica.

6

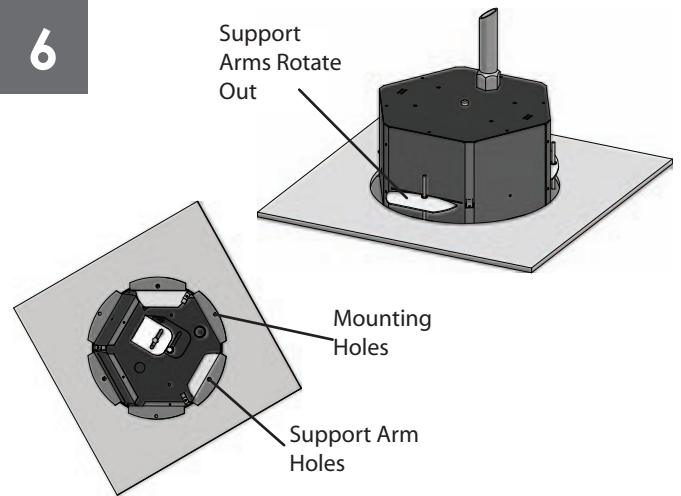

With the bottom flange pressed against the ceiling, rotate support arms to the outside. Tighten the support arm screws.

- Con el fondo el reborde presionó contra el techo, rota los brazos de ayuda al exterior. Apriete los tornillos del brazo de ayuda.
- Avec le fond la bride a serré contre le plafond, tourment des bras de soutien jusqu'à l'extérieur. Serrez les vis de bras de soutien.
- Mit Unterseite betätigte sich der Flansch gegen die Decke, drehen Lagerarme zur Außenseite. Ziehen Sie die Lagerarmschrauben fest.
- Com fundo a flange pressionou de encontro ao teto, gira os braços de sustentação à parte externa. Aperte os parafusos do braço de sustentação.
- Con la parte inferiore la flangia ha premuto contro il soffitto, ruota l'armi di sostegno alla parte esterna. Stringa le viti del braccio di sostegno.

7

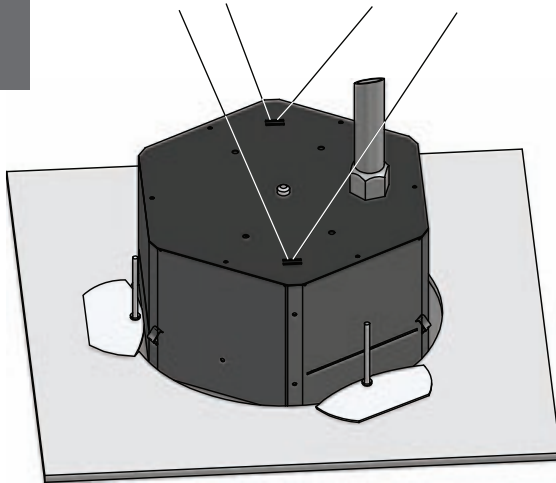

If required, secure housing by running bolts in the bottom flange and support wires from a solid structure.

- Si está requerido, asegure los pernos del funcionamiento de la cubierta en el reborde inferior y apoye los alambres de una estructura sólida.
- S'il y a lieu, fixez les boulons de course de logement dans la bride inférieure et soutenez les fils d'une structure pleine.
- Wenn erforderlich sichern Sie Gehäusedurchlaufschaubolzen im unteren Flansch und stützen Sie Leitungen von einer festen Struktur.
- Se requerido, fixe os parafusos do funcionamento da carcaça na flange inferior e suporte fios de uma estrutura contínua.
- A richiesta, assicuri i bulloni di funzionamento dell'alloggiamento nella flangia inferiore e sostenga i legare da una struttura solida.

8

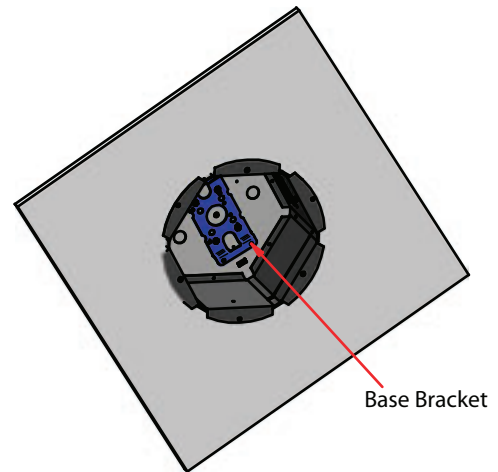

The camera may be mounted on either side of the tilted part of the camera bracket.

- La cámara fotográfica se puede montar de cualquier lado de la pieza inclinada del soporte de la cámara fotográfica.
- L'appareil-photo peut être monté de chaque côté de la pièce inclinée de la parenthèse d'appareil-photo.
- Die Kamera kann vom gekippten Teil des Kamerahaltewinkels auf beiden Seiten angebracht werden.
- A câmera pode ser montada em um ou outro lado da peça inclinada do suporte da câmara.
- La macchina fotografica può essere montata da qualsiasi lato della parte inclinata della staffa della macchina fotografica.

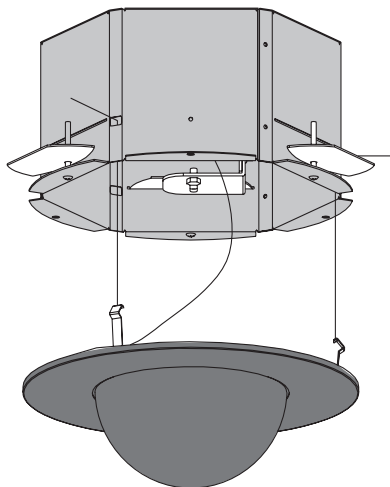

Reattach the trim ring/ dome assembly by pressing in and sliding (3) springs in the housing.

- Reate el montaje de la bóveda del anillo del ajuste clavando y resbalando (3) los resortes en la cubierta.
- Rattachez le dôme d'anneau d'équilibre en enfonçant et diapositive (3) des ressorts dans le logement.
- Befestigen Sie die Ordnung Ringhaube wieder, indem Sie (3) Federn im Gehäuse eindrücken und schieben.
- Reate o conjunto da abóbada do anel da guarnição pressionando dentro e deslizando (3) as molas na carcaça.
- Riattacci il complessivo della cupola dell'anello della cornice introducendo e diapositiva (3) le molle nell'alloggiamento.

Replacement Parts List

**MR7CN
MR7TN**

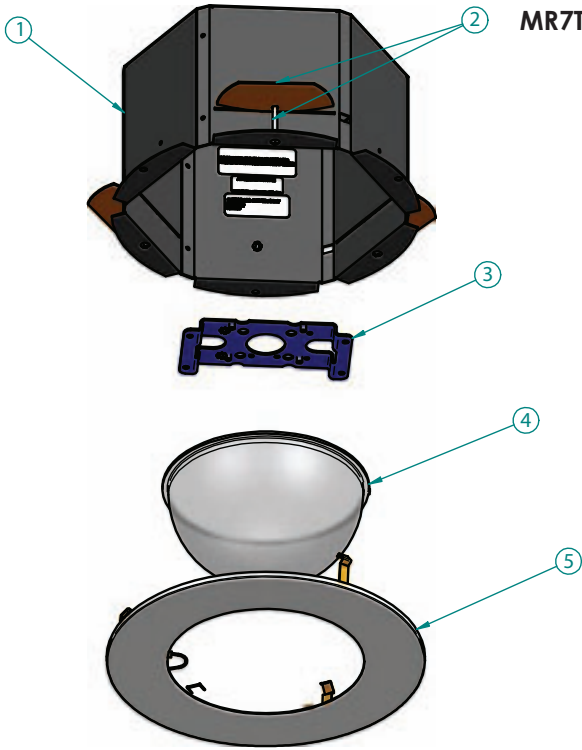

Part Number	Description
1	RPMR7010 MR7 TOP HOUSING ASSEMBLY
2	RPMR7020 MR7 SUPPORT ARMS KIT (SET OF 3)
3	RPNET04 NETWORK BASE BRACKET
4	RCMR7T REPLACEMENT CAPSULE FOR MR7T HOUSING
	RCMR7C REPLACEMENT CAPSULE FOR MR7CL HOUSING, NO SILKSCREEN, LINER
5	RPMR7050 WHITE TRIM RING ASSEMBLY
6	RPPKH2071 UNIVERSAL NETWORK PACKET & HARDWARE
7	RP46PKH2094 UNIVERSAL NETWORK PACKET (AXIS) & HARDWARE

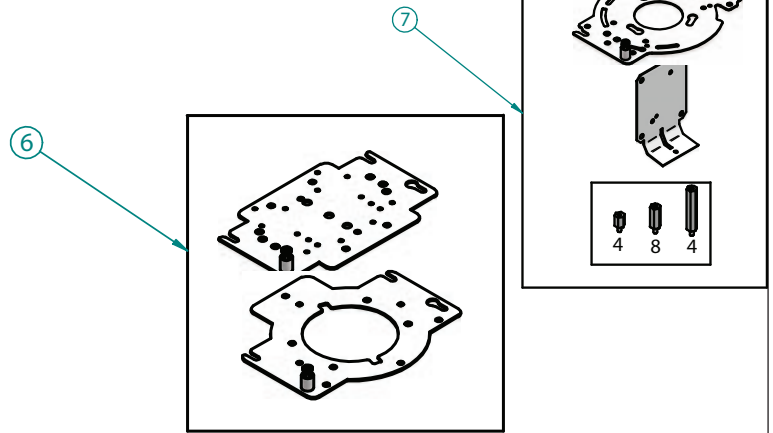

Camera Mounting Instructions



NOTE:



English

For all RHP and RHW models a ½" (13mm) spacer is added for additional height.



Deutsch

Für alles RHP und RHW modelliert eine ½" (13mm) Distanzscheibe hinzugefügt für zusätzliche Höhe.



Español

Para todo el RHP y RHW modela un espaciador del ½" (13mm) se agrega para la altura adicional.



Portuguese

Para todo o RHP e RHW modela um espaçador do ½" (13mm) é adicionado para a altura adicional.



Français

Pour tous les RHP et RHW modèle entretoise de ½ une » (13mm) est ajouté pour la taille additionnelle.



Italiano

Per tutti i RHP e RHW modella un distanziatore del ½,, (13mm) si aggiunge per altezza supplementare.

(HARDWARE)

(SPACING)

(1)



(1)



(1)



(88mm)

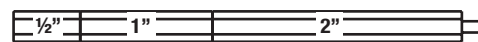

ACTi: ACM 8511

○ Mounting holes

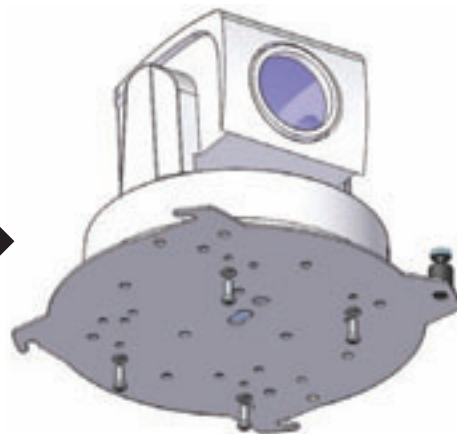
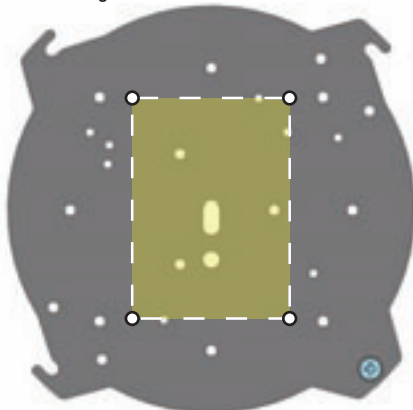

(4-M3)



(4)



(88mm)



ARECONT: AV8185 / AV8365 / AV20185 / AV20365

- Mounting holes

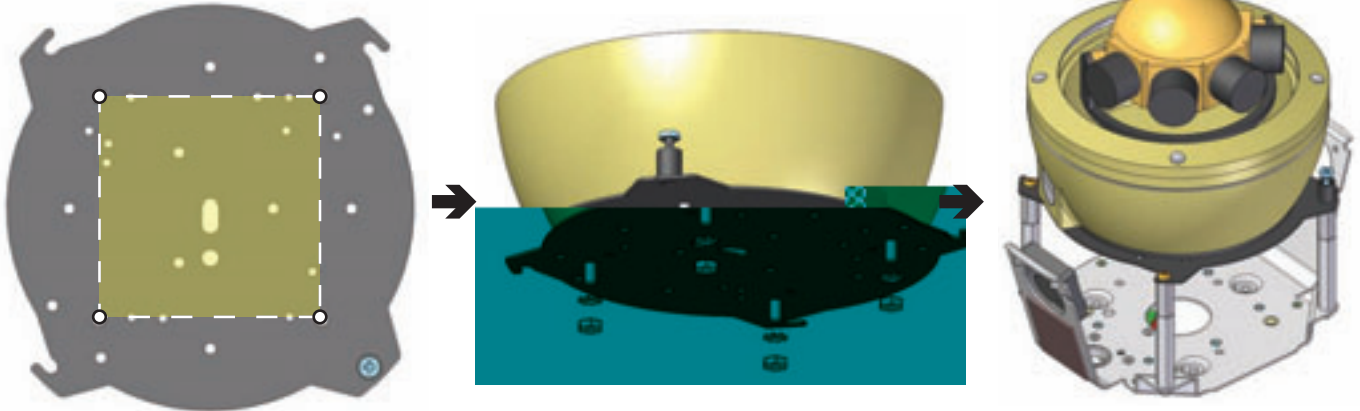

(4-#8 x 3/4")



(4)



(4)



(75mm)

1"

2"

AVIGILON: HD-Dome Series

- Mounting holes



(3-#8)



(3)



(3)



(100mm)

1"

1"

2"

AXIS: 214

- Mounting holes

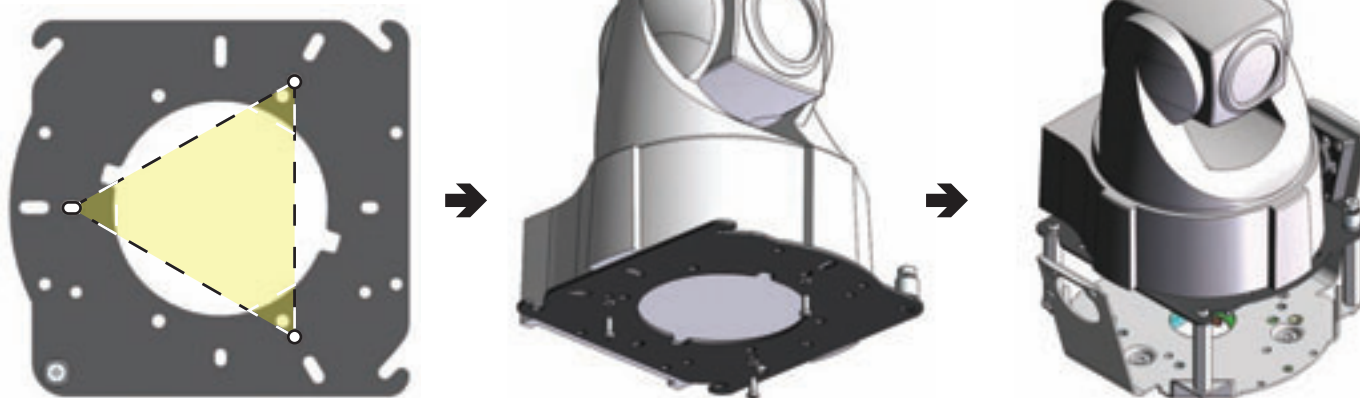

(3-M3)



(3)



(50mm)

2"

AXIS: 215

- Mounting holes

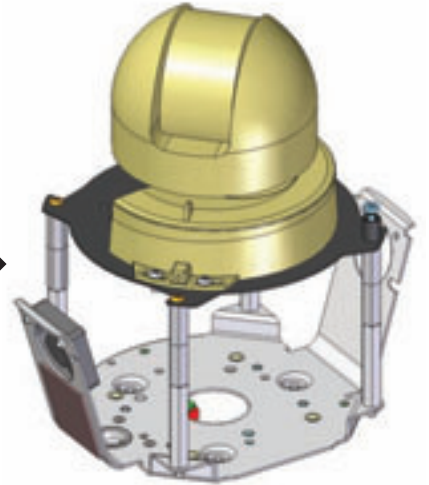
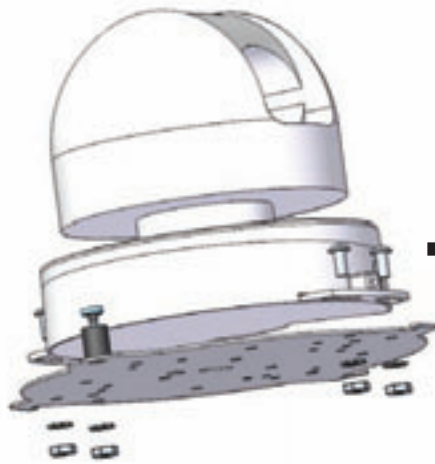
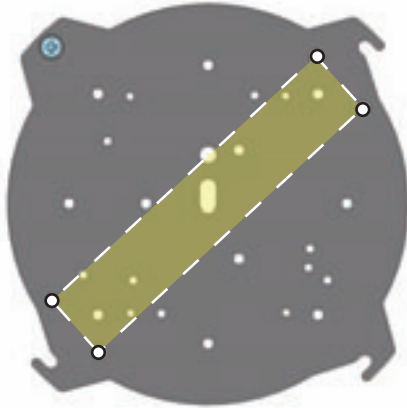

(4-#8)



(4)



(4)



(100mm)



AXIS: 233D

- Mounting holes

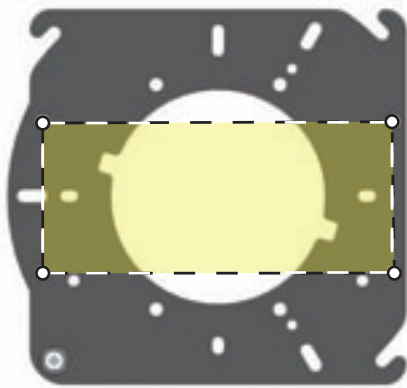

(4-#8)



(4)



(4)



(25mm)



BASLER: BIP2-1000C-DN / BIP2-1300C-DN / BIP-D1000C-DN / BIP-D1300C-DN

- Mounting holes

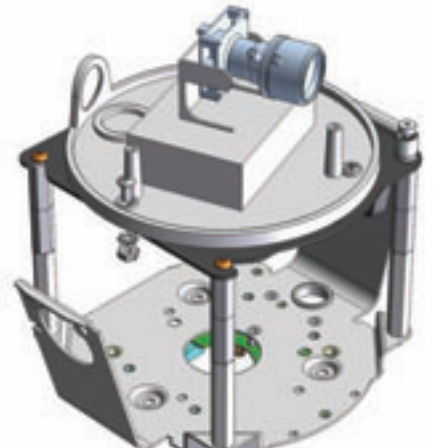
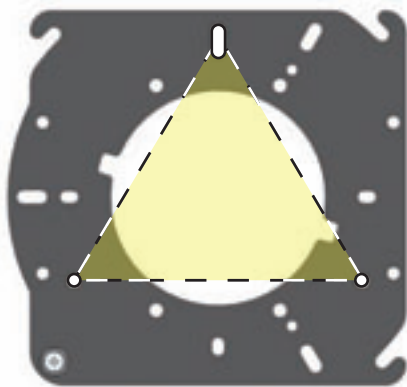

(3-#8)



(3)



(3)



(100mm)



CANON: VB-C60

○ Mounting holes



(64mm)



CANON: VB-M40

○ Mounting holes



(64mm)

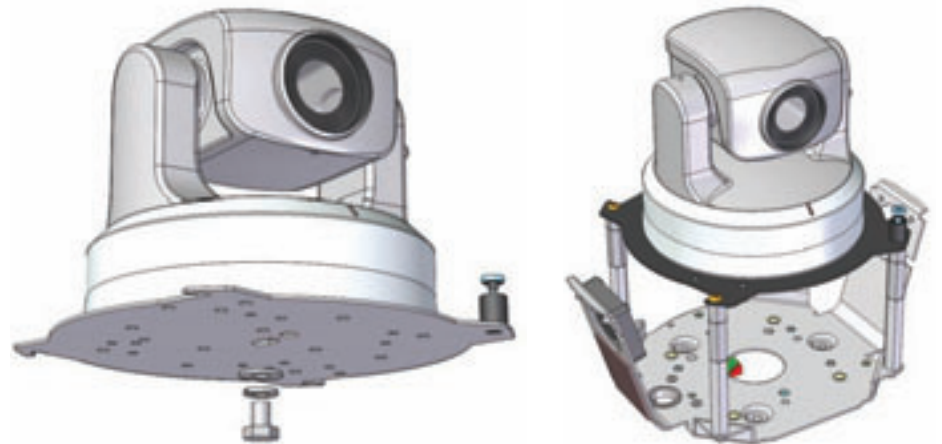

ELMO: PTC 400C

◦ Mounting holes

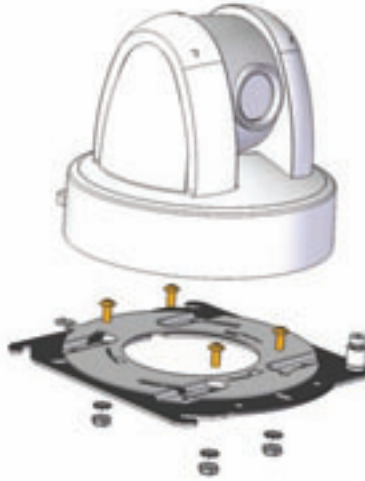
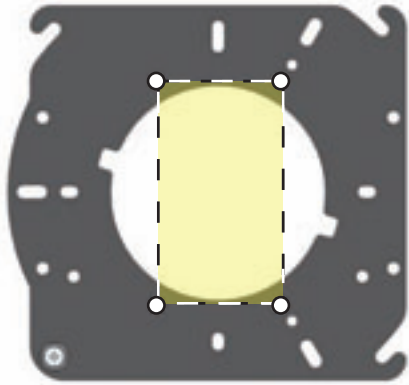

(4-#8)



(4)



(4)



(100mm)



JVC: VN-V686BU / VN-V685U

◦ Mounting holes

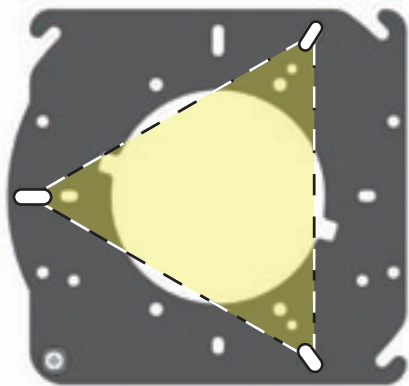

(3-#8)



(3)



(38mm)



PANASONIC: BB-HCM580/581

◦ Mounting holes

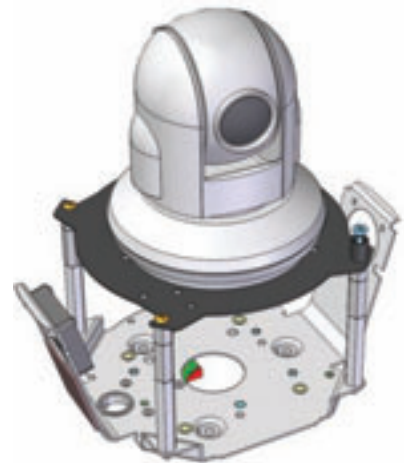

(1)



(1)



(1)





(88mm)

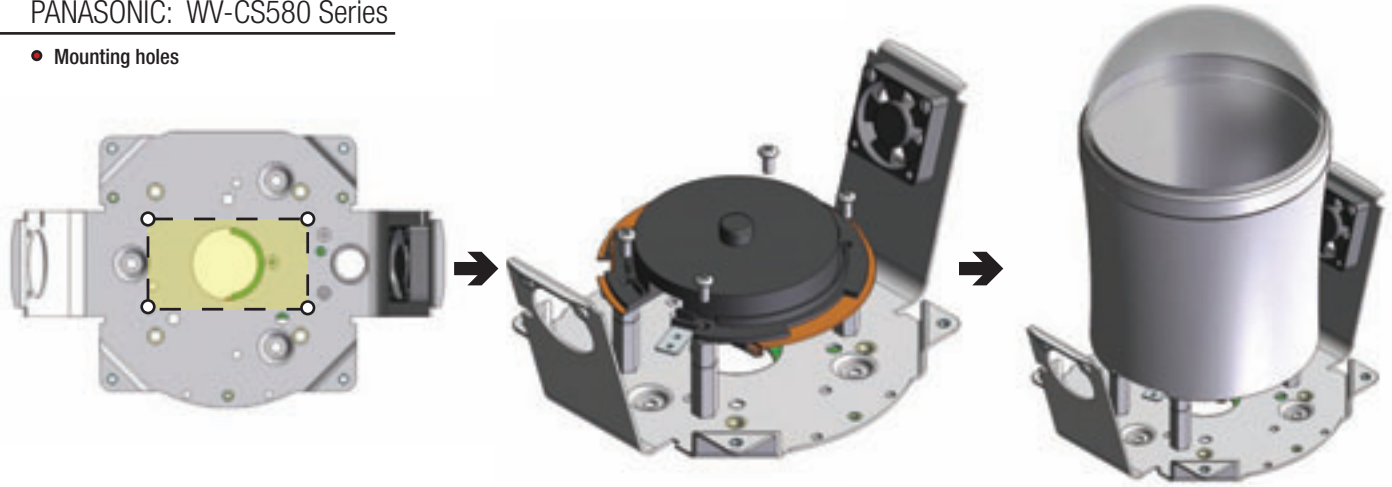

PANASONIC: WV-CS580 Series

- Mounting holes



(4-#8) 

(38mm) 

PANASONIC: SC386

- Mounting holes

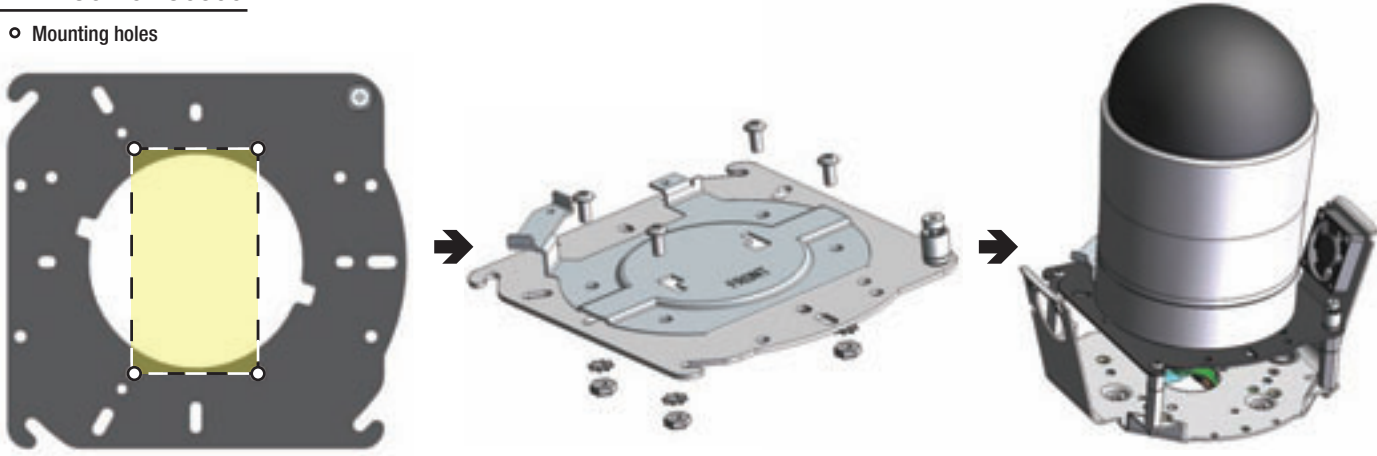

(4-#8)  (4)  (4) 

(25mm) 

PANASONIC: WV-CS574

- Mounting holes

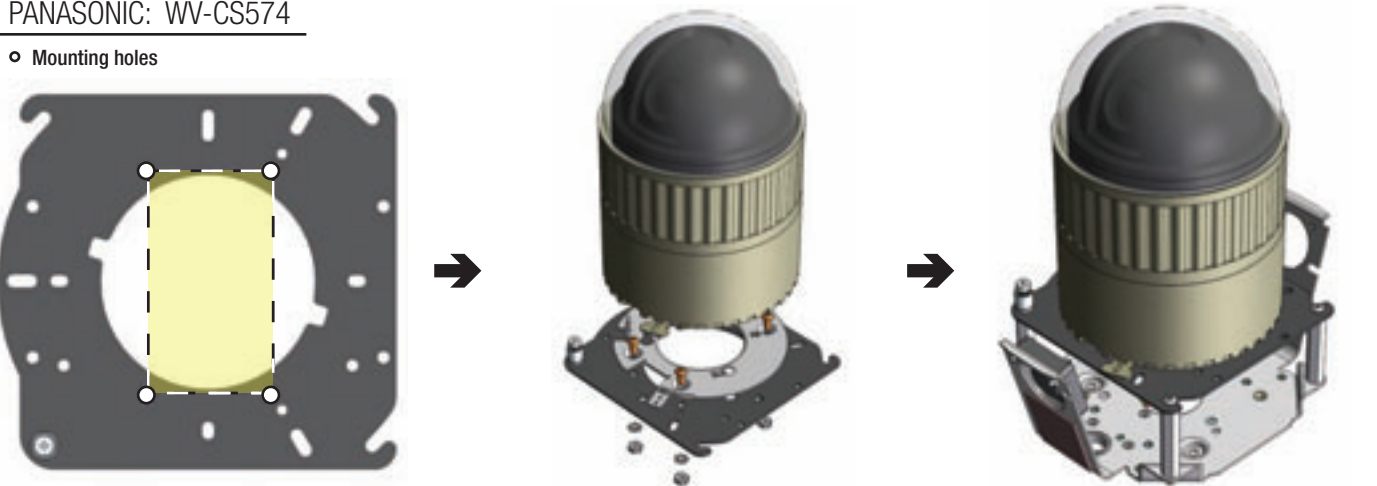

(4-#8)  (4)  (4) 

(50mm) 



SANYO: VCC-HD 5400

◦ Mounting holes

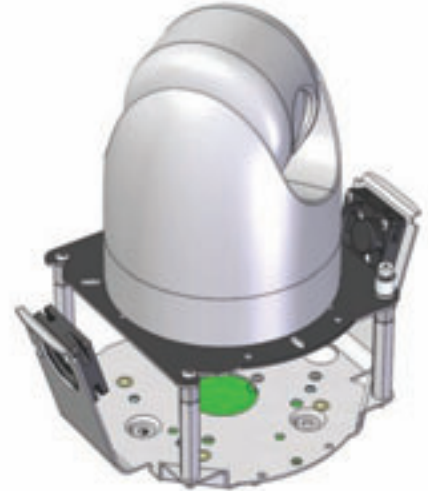
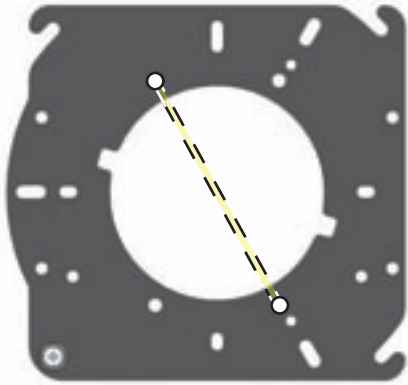

(2-#8)  (2) 

(64mm)

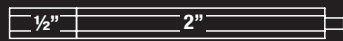

SONY: EP / ER Series (520 / 550 / 580)

◦ Mounting holes

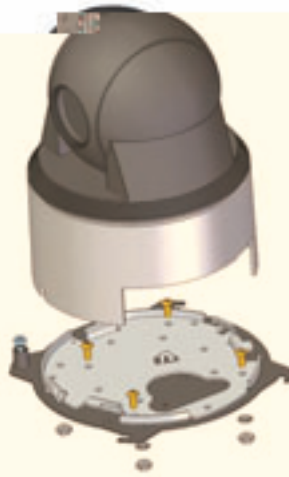
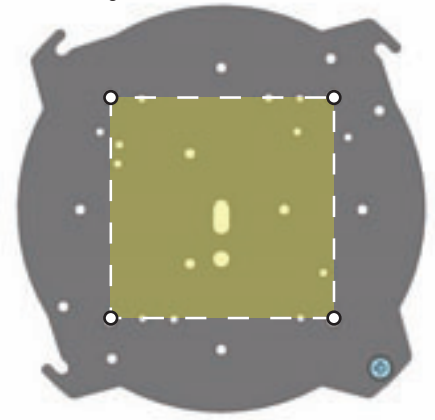

(4-#8)  (4)  (4) 

(38mm)



SONY: RX Series (RX530 / RX550 / RX570)

◦ Mounting holes

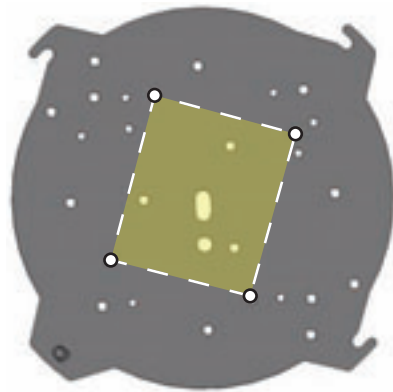

(4-M3)  (4) 

SONY: SNC RH/RS Series (RH124 / RS44 / RS46)

○ Mounting holes

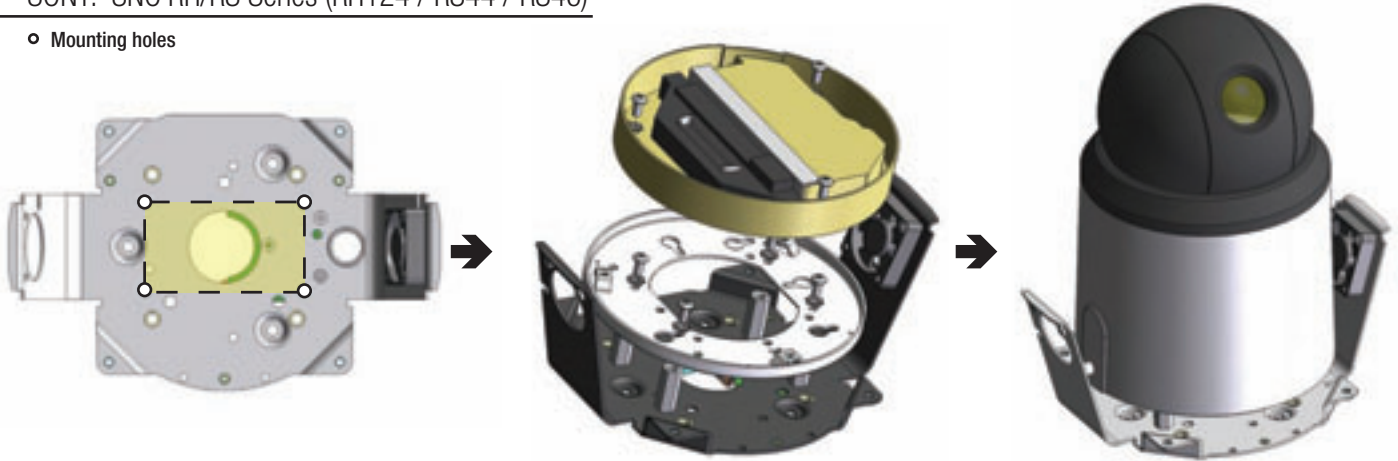

(4-#8)  (4) 

(25mm) 

SONY: SNC-RZ25

○ Mounting holes



(2-M3)  (2)  (1)  (1)  (1) 

(13mm) 

SONY: SNC-RZ50

○ Mounting holes

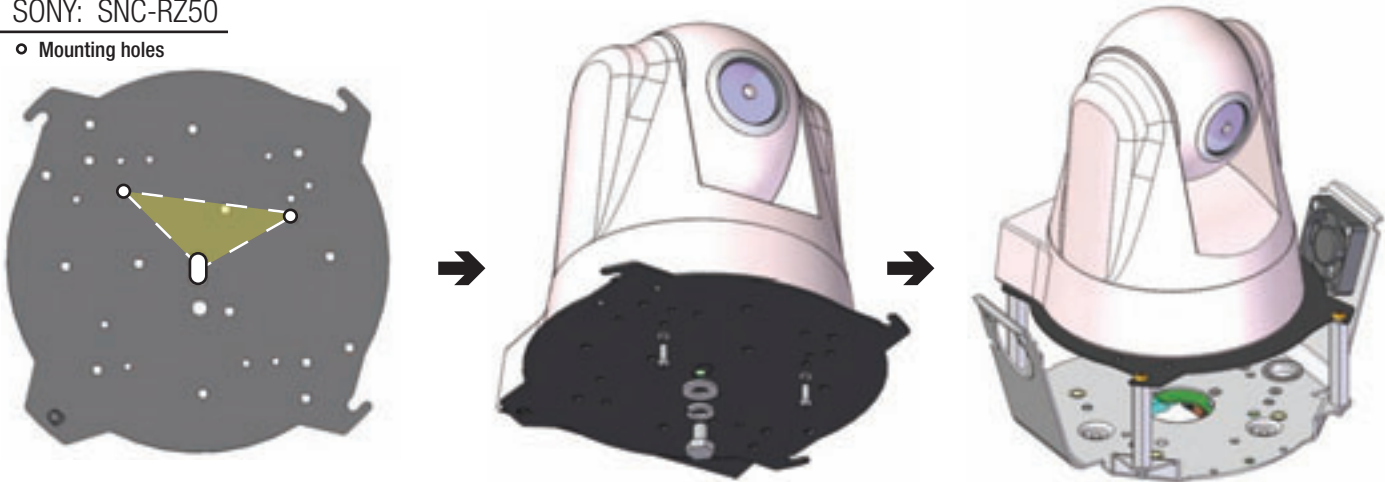

(2-M3)  (2)  (1)  (1)  (1) 

(50mm) 

TOSHIBA: IK-WB16A

○ Mounting holes

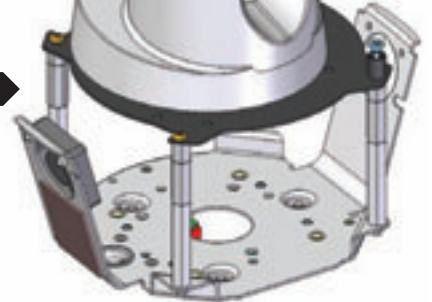

(88mm)

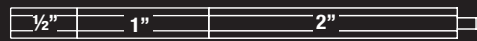

TOSHIBA: IK-WB21A

○ Mounting holes

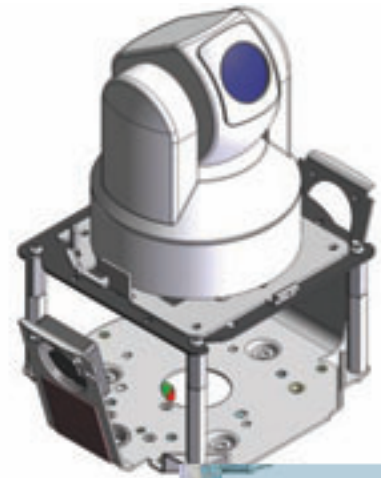
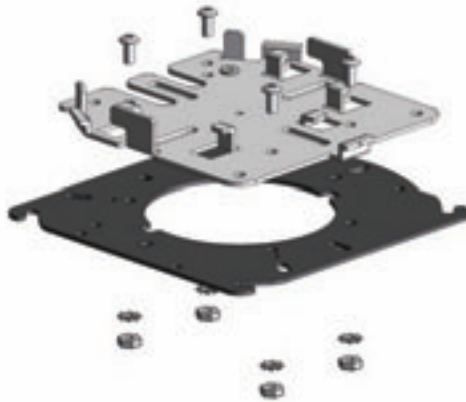
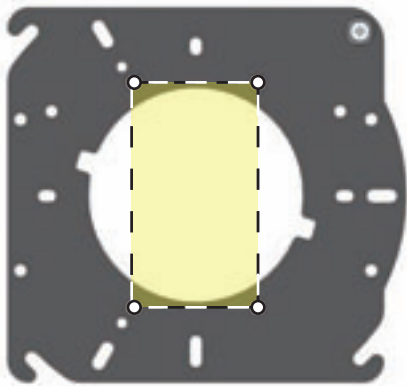

(75mm)



VIDEO IQ: VIQ-CT / CID / CRD / HD-CRD

○ Mounting holes

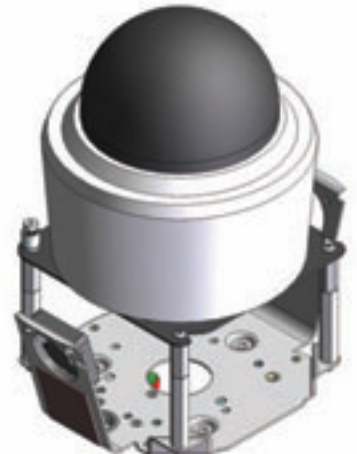
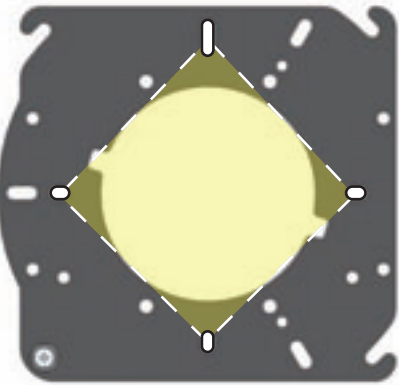

(4-M4x10)



(75mm)



Product Registration/Warranty

Thank you for choosing Moog Videolarm. We value your patronage and are solely committed to providing you with the highest quality products available and superior customer service.

Should a problem arise, rest assure that Moog Videolarm stands behind its products by offering impressive warranty plans: 3 Years on all Housings, Poles, Power Supplies, and Accessories and 5 Years on camera systems (SView, QView, Warriors), and InfraRed Illuminators.



Register Your Products Online

Take a few moments and validate your purchase via the Online Product Registration Form at
www.videolarm.com/productregistration.jsp

Register your recent Moog Videolarm purchases and benefit from the following:

- Simple and Trouble-Free RMA process
- Added into customer database to receive product updates / news
- Eliminate the need to archive original purchase documents:
Receipts, Purchase Orders, etc...