

INSTALLATION INSTRUCTIONS**DIRECT CONNECTION REDEYE STAGE 1 KIT**

DODGE CHALLENGER SRT® HELLCAT REDEYE 6.2L HO

DODGE CHARGER SRT® HELLCAT REDEYE 6.2L HO

DODGE CHALLENGER SRT® DEMON 6.2L

PART NUMBER: 77072583AB



www.dcperformance.com



TO PREVENT **SERIOUS INJURY** AND **PROPERTY DAMAGE**, YOU SHOULD READ, UNDERSTAND AND FOLLOW THE WARNINGS AND INSTRUCTIONS IN THIS MANUAL **PRIOR** TO INSTALLATION. FOR ASSISTANCE CONTACT **DIRECT CONNECTION TECH HOTLINE 1-800-998-1110**

STAGE II



The installation of a Hellcat Redeye Pre-Stage Kit is required to install the Hellcat Redeye Stage II Kit onto your vehicle.

See Direct Connection Tuner section for more details.

Bill of Materials

Part Description	Part Number	Service Parts	Quantity
Calibration Keychain	DC-KC002	Contact DC	1
80.5 mm Supercharger Pulley	920674	Contact DC	1
CARB EO Label	EO Label	Contact DC	2
Instruction Sheet	K6864149AB	Online	1

Special Tools Required for Install

Part Number	Description	Source
HPT2000	Pin Holding Tool	Metco
HPT2001	Pin Holding Tool Adapter	Metco
04318083AC	Anaerobic Sealant	Mopar
Various	24mm Hex Bit Socket	Various

New Parts Required for Install

Part Number	Description	Quantity	Source
68271246AA	Intake Gasket (Incl. L & R Side)	1 (optional, replace if damaged)	Mopar
68373848AA	Supercharger Lid Gasket Kit	1	Mopar
68271245AA	Throttle Body to Intake Seal	1	Mopar
68271253AA	Throttle Body Screw	4	Mopar
68271249AB	T-MAP Screw	1	Mopar

Contents

- Supercharger Pulley (Decoupler) 3
 - Removal..... 3
- Air Intake Air Duct Removal 3
- Supercharger Belt Removal 3
- Supercharger Nose Removal..... 3
- Stock Decoupler Removal 5
 - Installation..... 5
 - Direct Connection Decoupler Installation..... 5
- Supercharger Nose Installation..... 5
- Supercharger Belt Installation 6
- Air Intake Air Duct Installation 6
- Direct Connection Tuner 7
 - Security Gateway Module Update – Redeye & Demon Vehicles Only 7
 - Keychain & Calibration Retrieval..... 7
 - Tuning..... 8
- High Octane Mode 9
 - Functionality..... 9
 - Fuel Requirements 9
- Dealer Installed Vehicle Option VIN Assignment 10
- California Air Resources Board Executive Label..... 10

DISCLAIMER

WARNING: Before using this device, read the complete User Manual. Never attempt to alter this device. This device is not intended for your attention while driving – distracted driving may cause motor vehicle accidents, death, or serious injury. User ASSUMES ALL RESPONSIBILITY and LIABILITY FOR ANY CLAIMS arising from distracted driving while using this device or from altering it. To AGREE and continue, select “Yes” from the Direct Connection Tuner Initial Startup.

Supercharger Pulley (Decoupler)

Removal

Air Intake Air Duct Removal

1. Disconnect and isolate the negative battery cable.
2. Remove the air intake air duct:
 - a. Loosen the clamps (1, 4) on the air duct (orange).
 - b. Move air duct aside and free from obstruction.

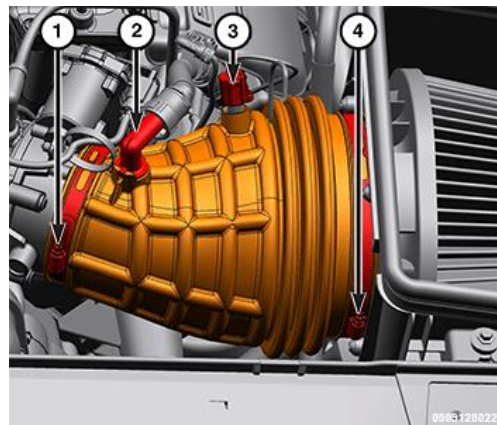

Supercharger Belt Removal

1. Remove the supercharger belt
 - a. Release the belt tension by rotating the tensioner (1) clockwise. Rotate the belt tensioner until the belt (2) can be removed from pulleys.
 - b. Remove the belt.
 - c. Gently release the tensioner.

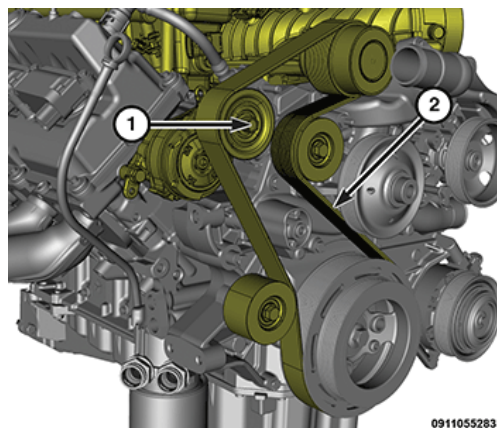

Supercharger Nose Removal

1. Remove the engine covers on either side of the supercharger.
2. Remove the cowl cover panel
3. Remove cowl cross brace & wiper arm linkage assembly
4. Disconnect the fuel purge hose from the supercharger nose and supercharger (1,2).
5. Disconnect the wire harness connector from the intermediate TMAP sensor located on the driver side, towards rear of supercharger (1,2).
6. Remove PCV hose from passenger side of the supercharger nose (1,2).

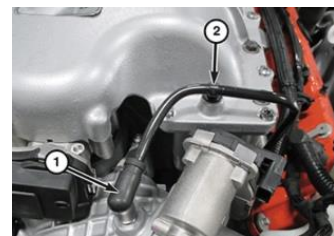

7. Disconnect the throttle body wire harness connector at the supercharger nose and disconnect the brake booster vacuum supply hose (under supercharger nose – not pictured).

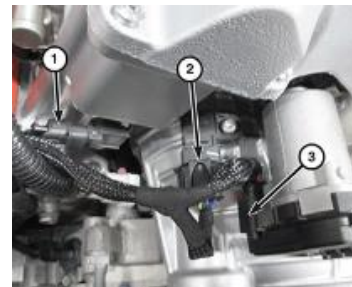

8. Disconnect the Bank 1 and (1) throttle output TMAP sensors (2), and bypass valve wire harness connectors (3).



9. Disconnect the wire harness connector (2) from the Bank 2 TMAP sensor (3).

10. Disconnect the fuel injector connectors from both sides of the supercharger.
 11. Remove the four throttle body screws and remove the throttle body from the inlet nose.
 a. Remove and discard the throttle body screws and inlet seal.
 12. Remove ten 10mm hex head bolts from supercharger cover (Start at #10 and work backwards to #1).



13. Remove the sixteen short bolts and five long bolts from the supercharger cover (T30).
 14. Remove the supercharger lid using the tab at the rear of the supercharger. Discard the lid gasket.
 a. Note: the six cooler retention seals must remain with the lid.
 b. Remove and discard the three lid tower O-ring seals from the supercharger.

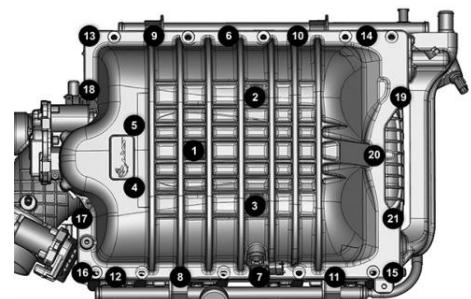

15. Remove the three bypass throttle body adapter screws (T30) and remove the adapter. Inspect seals for damage and discard if necessary.
 16. Remove the TMAP sensor from the inlet nose and discard the fastener.
 17. Tilt the front edge of the supercharger up and support with rubber or wooden blocks.
 Note: the lifting operation will require the help of an assistant. Take care to avoid pinching.
 Take care to avoid damaging the supercharger to cylinder head intake gaskets during this operation.
 18. Remove the six screws from around the inlet nose and discard.
 19. Remove the inlet nose carefully to not damage any of the supercharger bushings. It is possible that they may remain on the supercharger inlet. **DO NOT DAMAGE** when removing.
 20. Remove all non-OE brackets and belt-wrap pulley kits. Substitutions can negatively affect system performance. Failure to follow this step could result in premature wear of the Direct Connection decoupler.

Stock Decoupler Removal

1. Remove the rubber cap on the stock supercharger decoupler. Puncture the center of the cap to pry off. Discard the old cap.
2. Support the pins on the back of the supercharger shaft. Use Metco tool MET-HPT2000 in conjunction with MET-HPT2001.
3. Once supported, remove the supercharger pulley using a 24mm hex tool. Rotate decoupler shaft in a counter-clockwise direction while holding the supercharger shaft stationary.
4. Inspect supercharger threads and ensure they are clean and in good condition.

Installation

Direct Connection Decoupler Installation

1. Take care when handling the decoupler. Never rest the decoupler on the front face (marking side) as this can shift the internals. Avoid impacting anywhere on the decoupler when handling or during installation. Do not disassemble the decoupler.
2. Thread Direct Connection decoupler on by hand until it contacts the supercharger front bearing. Install the decoupler using the 17mm hex tool and supporting the pins on the rear of the supercharger shaft. Torque spec = $80 \text{ Nm} \pm 10 \text{ Nm}$ (or $59 \text{ ft.lbf} \pm 7 \text{ ft.lbf}$). **Do not** use an impact gun or air tool to install the decoupler.
3. Use a feeler gauge to check the gap between the rear of the decoupler pulley and the supercharger nose. If the gap is less than 2mm, remove the decoupler and reinstall with the provided washer between the decoupler and the supercharger bearing. If no washer was provided, use McMaster-Carr 97022A549. Repeat Installation Step 2.
4. **IMPORTANT:** Gently press the new rubber seal cap on the front of the decoupler by hand (do not use a mallet or other device). Ensure it is fully seated in the groove all the way around. Otherwise, dust and debris could collect inside and cause damage to the decoupler.

Supercharger Nose Installation

1. Inspect supercharger pulley pin bushings for damage (1). A plastic or rubber mallet can be gently used. **DO NOT CONTACT THE ALUMINUM INLET BEARING HOUSING**
2. Apply 1/8" bead of anaerobic sealant to mating surface and install the inlet nose to the supercharger. New bolts are provided in gasket kit Mopar Part: 68373848AA.

Torque spec = **35 Nm (26 ft.lbf)**. Use sequence:

- a. Lower center
 - b. Upper center
 - c. Upper left
 - d. Lower left
 - e. Lower right
 - f. Upper right
3. Reinstall the bypass adapter using a new gasket if damage was found on the original. Torque spec = **10 Nm (7 ft.lbf)**.
 - a. Lubricate the upper internal diameter using clean engine oil
 4. Install the three new tower lid O-rings to the supercharger.
 5. Lubricate the inlet nose TMAP sensor O-ring with clean engine oil. Install and tighten new fastener. Torque spec = **6 Nm (53 in.lbf)**.
 6. Install new lid gasket into the supercharger.
 7. Ensure the six cooler retention seals (1) are still assembled in lid
 8. Align lid and press about the bypass throttle body into the cuff.

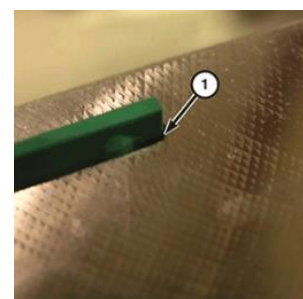
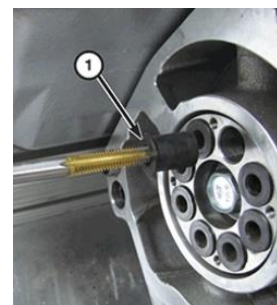

9. Tighten the twenty-one T30 bolts to **10 Nm (7 ft.lbf)**.
Use sequence to the right. Once done, tighten bolts #1 – #5 again to 10 Nm (7 ft.lbf).
10. Using a new seal, install throttle body onto inlet nose and torque four bolts to **10 Nm (7 ft.lbf)**.
11. Remove the supports from under the front of the supercharger.
Note: the lifting operation will require the help of an assistant. Take care to avoid pinching.
12. Tighten the ten supercharger bolts using the pattern here (start at #1).
 - a. Tighten all bolts in sequence to 5 Nm (4 ft.lbf).
 - b. Then repeat sequence and tighten to 15 Nm (11 ft.lbf).
 - c. Repeat the sequence one more time and tighten to 30 Nm (22 ft.lbf).
13. Reinstall all removed components and connectors in reverse order.

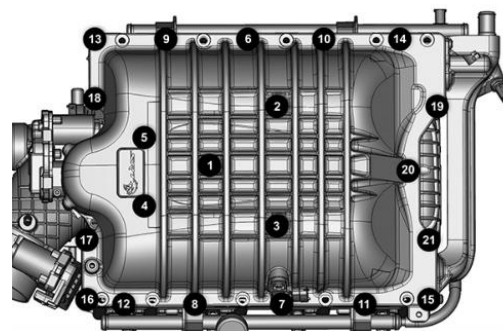

Supercharger Belt Installation

NOTE: When installing the supercharger drive belt onto the pulleys, make sure that the belt is properly routed and all V-grooves make proper contact with the pulleys.

1. Ensure the belt is free of tears, cracks, or other damage
2. Position the drive belt (2) over all pulleys, except for the idler pulley.
3. Rotate the tensioner (1) **clockwise** and slip the belt over the idler pulley.
4. Gently release tensioner

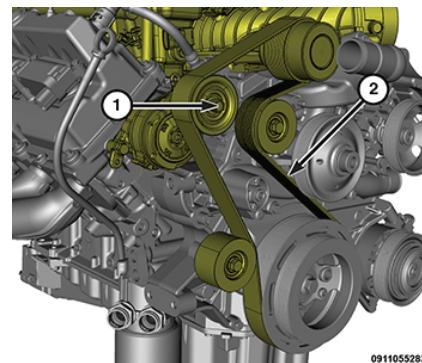

Air Intake Air Duct Installation

1. Install the air duct and securely tighten the clamps (1, 4).
2. Connect the Inlet Air Temperature (IAT) sensor wire harness connector (3).
3. Connect the negative battery cable

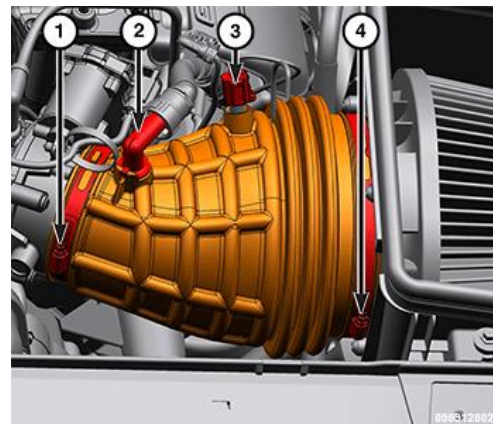

Direct Connection Tuner

The purchase of a Hellcat Redeye Pre-Stage Kit is required to install the Hellcat Redeye Stage II Kit onto your vehicle. It is required that you reference all applicable material related to flashing your vehicle found within the DC Tuner Manual and Pre-Stage Kit Instruction Sheets before installing the Stage II Kit.

Please review the table below for the applicable Pre-Stage Kit part number for your vehicle:

Application	Part Number	Part Description
2018 Challenger Demon		
2019-2023 Challenger Hellcat Redeye 6.2L HO	77072579AD	Challenger Pre-Stage Kit
2020-2023 Challenger Super Stock		
2021-2023 Charger Hellcat Redeye 6.2L HO	77072605AA	Charger Pre-Stage Kit

NOTE: Revision level (suffix) of part numbers are subject to change. Contact dealer or DC Hotline for the latest released part number

Security Gateway Module Update – Redeye & Demon Vehicles Only

In order for all features of the Direct Connection Tuner to function properly, make sure your Security Gateway Module is flashed with calibration **68593431AB**. Redeye, Super Stock, and Demon Vehicles Only. See dealer to install.

NOTICE

It is necessary to complete the Security Gateway module update **BEFORE** connecting to the Direct Connection Tuner. Failure to do so will result in reduced functionality.

Keychain & Calibration Retrieval

- Select the “**Stage Codes**” icon from the **Main Menu**.
This is the Stage Code entry for unlocking additional Stage Calibrations. This code comes printed on the keychain provided in the kit. **For more information, please call the Direct Connection Hotline at 1-800-998-1110.**
- Press the “+” in the Top-Right of the screen and enter the Keycode on the back of the provide Calibration Keychain when prompted.
- The applicable Stage Calibration for your vehicle is now available to flash. Follow the Tuning steps below.

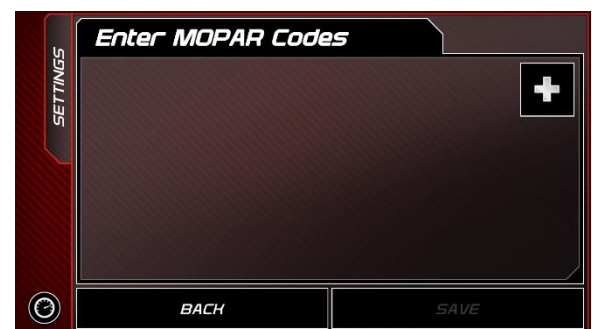
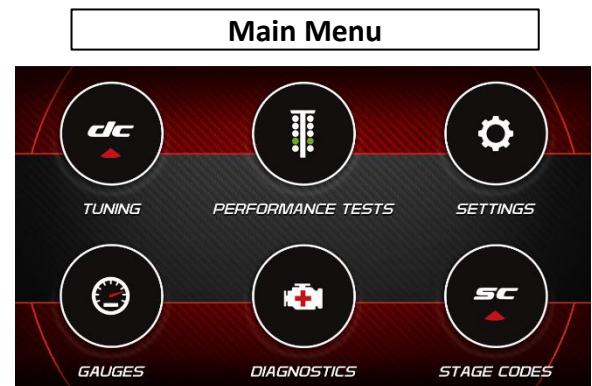

Tuning

1. Reboot the device after entering the stage code.
2. Install a battery charger to the vehicle to maintain constant battery voltage, otherwise communication with onboard ECUs may be lost and ECUs can be damaged during Tuning.
3. **REQUIRED:** Select “Settings”, then check the device for any available software updates. A Wi-Fi connection is necessary. If updates are available, the device will provide the option to perform the update.
4. Return to the Main Menu and Select the **Tuning** icon.
5. Turn the vehicle ignition to ON. Engine must remain OFF. Select “Tune Vehicle”. Follow the on-screen instructions.
6. Select Stage II. Follow the on-screen instructions.
7. Choose **Accept and Install** to continue. Follow on-screen instruction.
8. Once your vehicle has been successfully tuned, press Continue to return to the **Main Menu**.

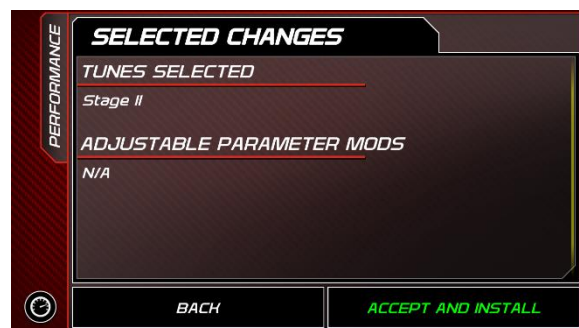
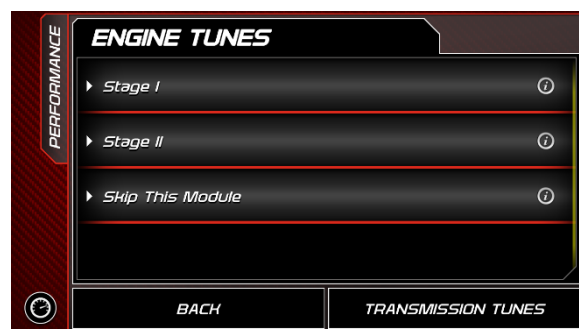
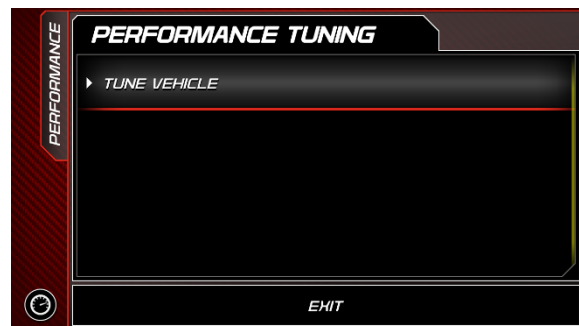
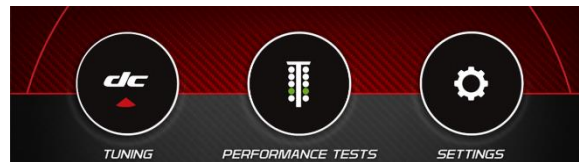

NOTICE

Do not remove or bump the OBD-II connector during any programming sequence. If you do, the vehicle may not start.

WARNING: Do not program the vehicle while parked in unsafe locations including in heavy traffic or places without cell phone service and the internet (if possible).

High Octane Mode

Functionality

Can be found by pressing the “Gauges” button within the Main Menu.

High Octane mode will default to OFF on start-up, to activate the High Octane mode press and release the High Octane button located within the Direct Connection Tuner. The LED indication light on the button will turn ON and a message will appear on the DC Tuner screen “High Octane ON.”

If the fuel requirements are not met, system error message “High Octane OFF Fuel Quality Too Low” will be displayed for 5 seconds as well as the LED indication light will flash. The High Octane mode will default to OFF.

To deactivate the High Octane mode, press and release the High Octane button located within the Direct Connection Tuner.

The LED indication light on the button will turn OFF and a message will appear on the DC Tuner screen “High Octane OFF.”

LED indication light will flash and a fault message will appear for 5 seconds and turn OFF if there is a system error.

System error messages are as follows:

- High Octane status cannot be changed with Foot on Gas.
- High Octane status cannot be changed when Cruise Control is Set.
- High Octane will be unavailable if there are System Faults.
- High Octane is not available in Reduced Power Modes.

High Octane mode will not remain ON if the ignition is cycled.

Fuel Requirements

NOTICE

Use of gasoline with a lower than recommended octane number or leaded gasoline can cause engine failure and may void or not be covered by the Direct Connection Limited Warranty.

When the High Octane mode is not engaged, a high-quality unleaded “Premium” gasoline having a posted octane number of 91 or higher as specified by the (R+M)/2 method is required. When the High Octane mode is engaged, the calibration requires high-quality unleaded gasoline with a posted octane number of 100 as specified by the (R+M)/2 method. If the fuel mixture in the tank does not meet the required 100 octane number during High Octane mode, the calibration will revert back to the factory octane calibration to avoid engine damage. Use of gasoline with a lower than recommended octane number or leaded gasoline can cause engine failure and may void or not be covered by the Direct Connection Limited Warranty.

High Octane OFF

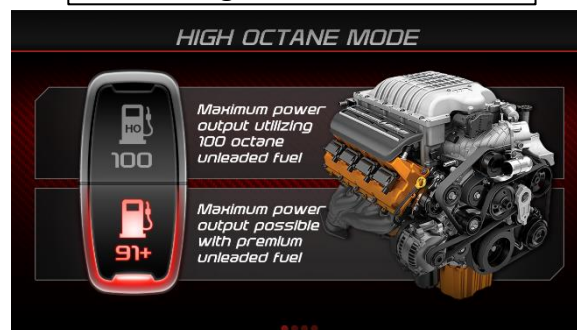

High Octane ON



Dealer Installed Vehicle Option VIN Assignment

After installing the stage kit on the vehicle, your Dodge Power Broker dealership can assign the Dealer Installed Vehicle Option to the vehicle VIN. See your Power Broker dealer to assign the appropriate option code associated with the stage kit that has been installed on your vehicle.

Vehicle Option Code	Application
6TQ	Redeye Pre-Stage Kit
6TR	Redeye Stage 1 Kit
6TS	Redeye Stage 2 Kit

NOTICE

It is advised to add Dealer Installed Vehicle Options after installing all stage kits to minimize communication interruptions with vehicle modules. 2018 Challenger Demon and Super Stock vehicles should use the same Option Codes as Redeye vehicles.

NOTICE

California Air Resources Board Executive Label

All models have a VECI Label. Chrysler permanently attaches the label in the engine compartment. It cannot be removed without defacing information and destroying the label.

Please place the CARB E.O. Label Supplied in the Kit directly next to the VECI label. **This product information label is required to aid in passing the California Smog Check program.**

NOTICE

If you are a 2018 Challenger Demon owner and your kit did NOT come with D-265-72 EO Labels, you MUST contact the DC Tech Hotline to have a D-265-72 EO label sent to you to meet CARB Installation Requirements. Either D-265-71 and D-265-72 EO Labels are OK to use on Challenger Redeye and Super Stock vehicles.

The label contains the Executive Order Number for the Direct Connection Hellcat Redeye Stage II Kit.



MOPAR

26311 Lawrence Ave
Center Line, MI 48015
888-528-HEMI

The following kit part number
has been issued under
C.A.R.B. E.O.

D-265-72
Redeye Stage 2 Kit
77072583AB

THIS PAGE INTENTIONALLY LEFT BLANK