



Direct Connection Performance Part

REDEYE PISTON AND ROD ASSEMBLY

PART NUMBER: 77072550AB

2015+ HELLCAT (6.2L)

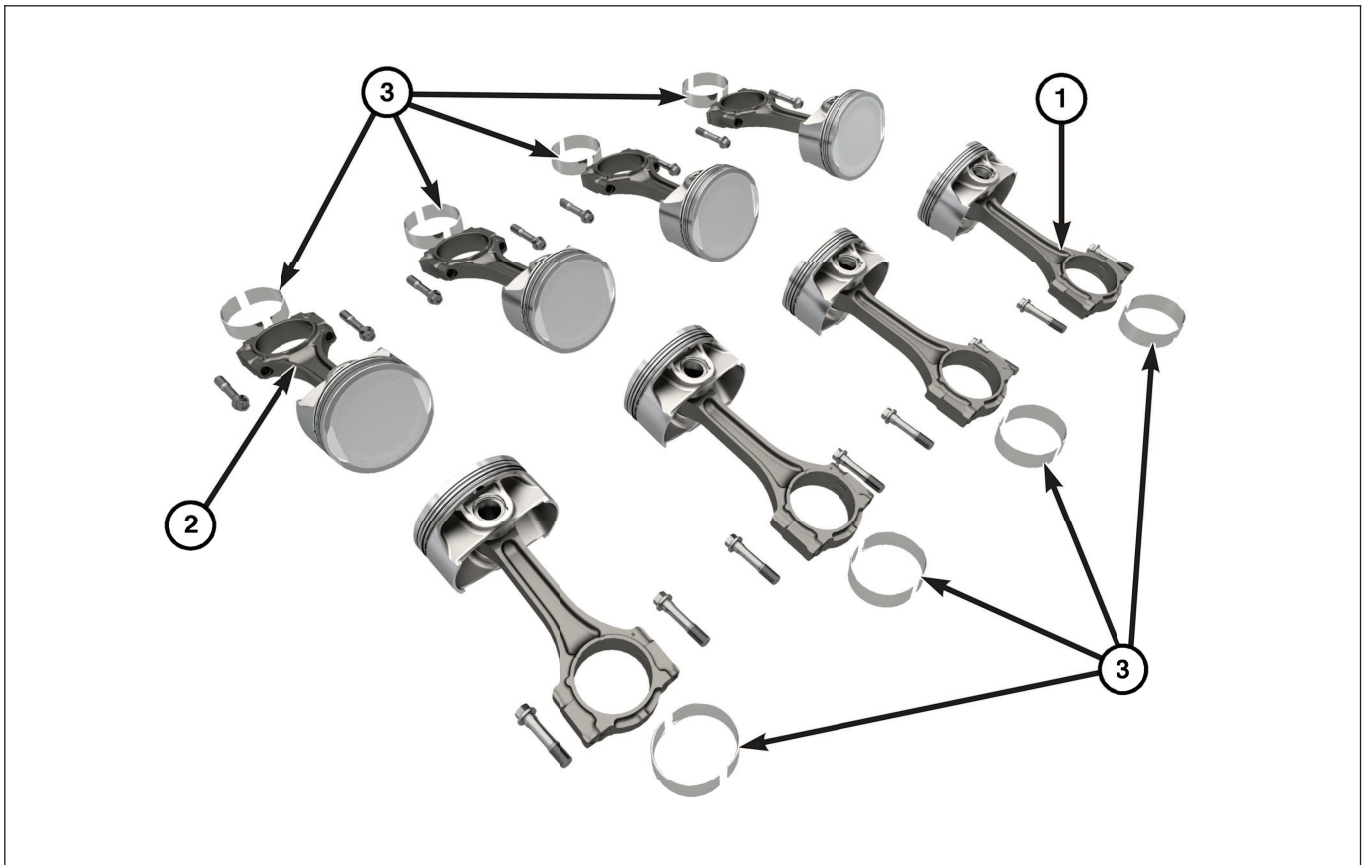

Item	Description	Part Number	Quantity
1	Piston, Pin, Rod Left Bank	53010809AF	4
2	Piston, Pin, Rod Right Bank	53010808AF	4
3	Bearings	68362046AA	8

Description	Capacities	Type
Engine Oil With Filter	7 Quarts / 6.6 Liters	The manufacturer recommends the use of Pennzoil Ultra 0W-40 or equivalent MOPAR engine oil meeting the requirements of FCA Material Standard MS- 12633 for use in all operating temperatures. We recommend you use MOPAR Engine Oil Filters.
Cooling System *	15.2 Quarts / 14.4 Liters Intercooler 4.5 Quarts / 4.2 Liters	Engine/Intercooler Coolant We recommend you use MOPAR Antifreeze/Coolant 10 Year/150,000 Mile Formula OAT coolant conforming to MS.90032.
Spark Plugs	GAP	We recommend you use MOPAR Spark Plugs.
	.043 in / 1.10 mm	

* Includes heater and coolant reservoir filled to MAX level.

PLEASE READ ALL INSTRUCTION PRIOR TO INSTALLATION.
FOR ASSISTANCE CONTACT DIRECT CONNECTION TECH HOTLINE 1-800-998-1110

REMOVAL

NOTE: Internal engine service is recommended as an out of vehicle service procedure.

- Remove the engine before attempting piston and connecting rod assembly replacement.
- Perform procedure with the engine mounted to a suitable engine service stand.

1. Remove the cylinder heads.
2. Remove the oil pan.
3. If necessary, remove the ridge on top of the cylinder bores with a reliable ridge reamer before removing pistons from engine block. **Be sure to keep the tops of the pistons covered during this operation.**

CAUTION! When removing and installing the pistons and connecting rods, do not damage the piston oil cooler jets. If the jets are bent, engine damage may occur.

4. Remove the piston oil cooler jets retaining bolts and remove the piston oil cooler jets.

CAUTION! Care must be taken not to nick crankshaft journals as engine damage may occur.

NOTE: Pistons and connecting rod assemblies must be removed from the top of the engine block. When removing the piston and connecting rod assemblies from the engine, rotate the crankshaft so each connecting rod is centered in the cylinder bore.

5. Remove the connecting rod cap and carefully remove the piston from the cylinder bore, repeat this procedure for each piston being removed.

INSTALLATION

NOTE:

- Make sure the piston ring grooves are clean and free of nicks and burrs.
- Connecting rods and bearing caps are not interchangeable and should be marked before removing to ensure correct assembly.
- Mark the connecting rod and bearing cap position using a permanent ink marker or scribe tool.

CAUTION!

- Do not use a number stamp or a punch to mark connecting rods or caps, as damage to connecting rods could occur.
- Care must be taken not to damage the fractured rod and cap joint face surfaces as engine damage may occur.
- Before installing new rings, the ring clearances must be checked.

1. Check piston ring clearance:
 - 1) Wipe the cylinder bore clean.
 - 2) Insert the piston ring into the cylinder bore.

NOTE: The piston ring gap measurement must be made with the piston ring positioned at least 12 mm (0.50 inch) from bottom of cylinder bore.
 - 3) Using a piston, make sure that the piston ring is squared in the cylinder bore. Slide the piston ring downward into the cylinder.
 - 4) Using a feeler gauge (1), check the piston ring end gap, replace any rings not within specification.

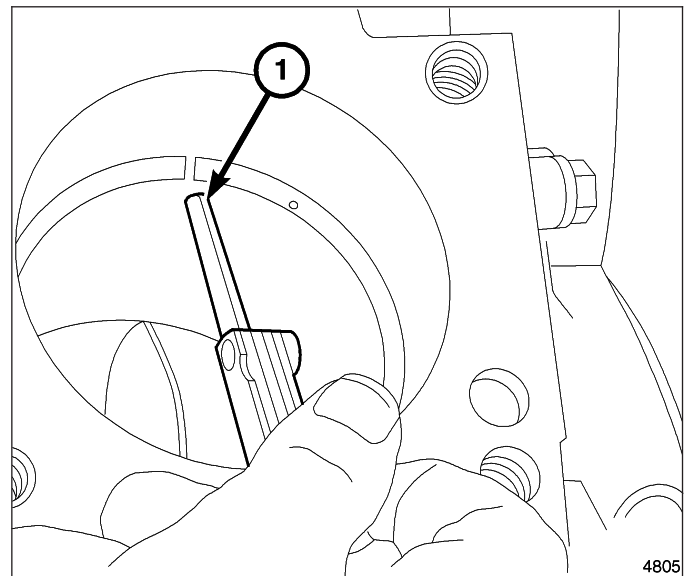

NOTE: Make sure the piston ring grooves are clean and free of nicks and burrs.

- 5) Measure the piston ring side clearance with a feeler gauge (1) as shown. Make sure the feeler gauge fits snugly between the piston ring land and the piston ring, replace any ring not within specification.

NOTE: Make sure the marks on the compression rings face upward.

- 6) Rotate the ring around the piston. The ring must rotate in the groove with out binding.

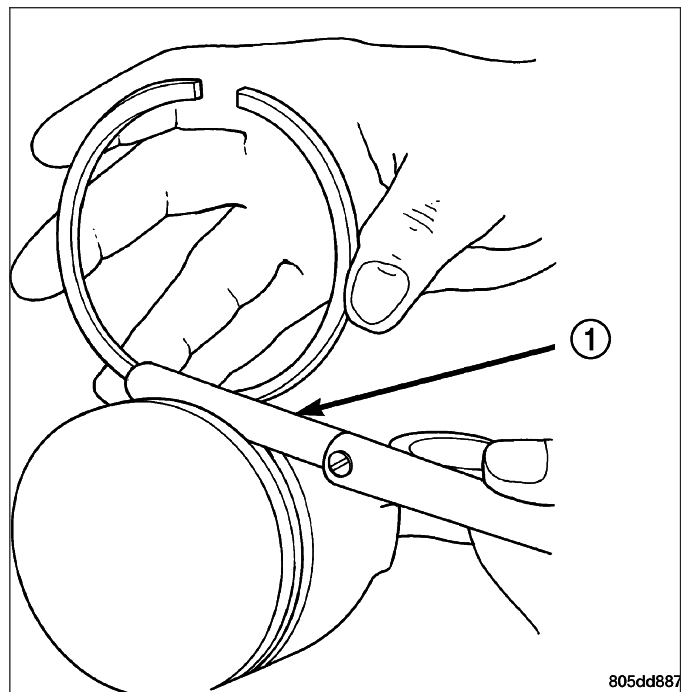

805dd887

PISTON RINGS

DESCRIPTION	SPECIFICATION	
	Metric	Standard
Ring Gap		
Top Compression Ring	0.35 - 0.50 mm	0.0138 - 0.0197 in.
Second Compression Ring	0.65 - 0.90 mm	0.0255 - 0.0355 in.
Oil Control (Steel Rails)	0.15 - 0.45 mm	0.0059 - 0.0177 in.
Side Clearance		
Top Compression Ring	0.040 - 0.072 mm	0.0016 - 0.0028 in.
Second Compression Ring	0.040 - 0.072 mm	0.0016 - 0.0028 in.
Oil Ring (Steel Ring)	0.061 - 0.210 mm	0.0024 - 0.0083 in.
Ring Width		
Top Compression Ring	1.172 - 1.190 mm	0.0461 - 0.0468 in.
Second Compression Ring	1.172 - 1.190 mm	0.0461 - 0.0468 in.
Oil Ring (Steel Rails)	0.387 - 0.413 mm	0.0152 - 0.0163 in.

2. Before installing piston and connecting rod assemblies into the bore, install the piston rings:

- 1) Install the oil ring expander.
- 2) Install the lower side rail by placing one end between the piston ring groove and the expander ring (1). Hold the lower side rail end firmly and press down the portion to be installed until the side rail is in position. Repeat this step for the upper side rail.

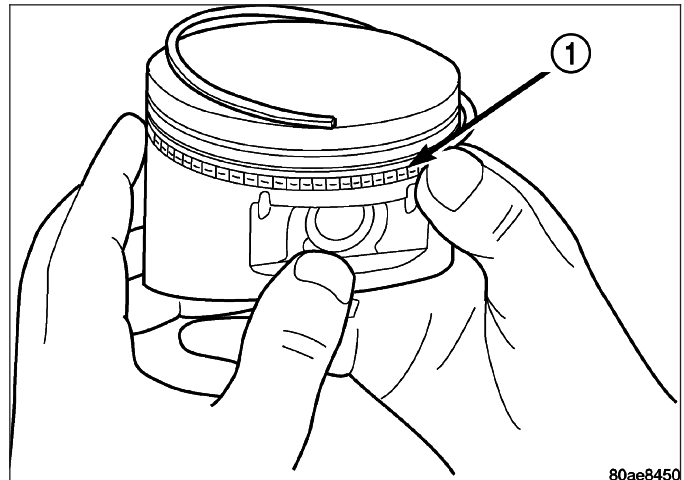

80ae8450

- 3) Using a piston ring installer, install the No. 2 intermediate piston ring.
- 4) Using a piston ring installer, install the No. 1 upper piston ring.

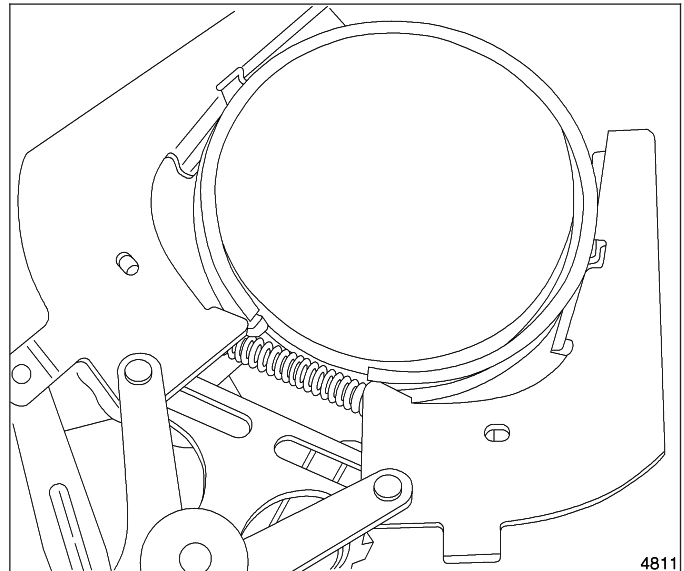

4811

- 5) Install the oil ring expander gap at the (5) position.
- 6) Install the oil ring lower side rail gap at the (4) position.
- 7) Install the oil ring upper side rail gap at the (1) position.
- 8) Install the second compression ring gap at the (5) position.
- 9) Install the top compression ring gap at the (2) position.

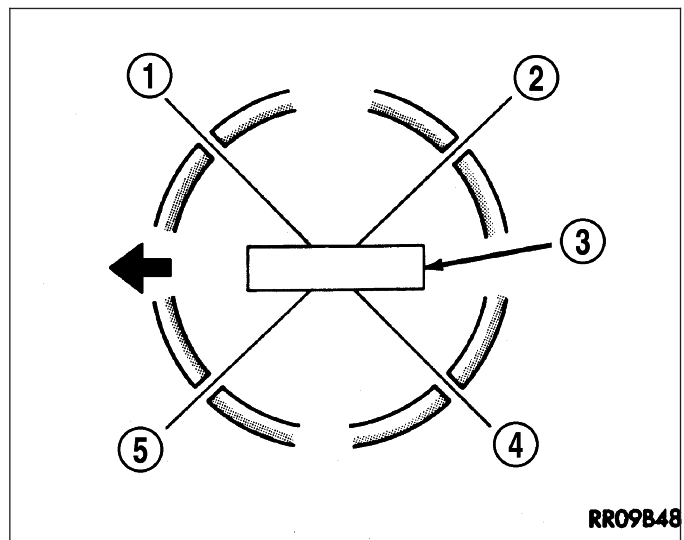

RR09B48

3. Immerse the piston head and rings in clean engine oil and position a ring compressor over the piston and rings and torque the ring compressor. **Make sure the position of rings do not change during this operation.**

4. The pistons are marked on the piston pin bore surface with an etched arrow on top of piston indicating installation position. This mark must be pointing toward the front of the engine on both cylinder banks.

5. Wipe the cylinder bore clean and lubricate with clean engine oil.

6. Rotate the crankshaft until the connecting rod journal is centered with the cylinder bore.

7. Insert the piston and rod assembly into the cylinder bore and carefully position the connecting rod over the crankshaft journal.

8. Push the piston down in cylinder bore using a hammer handle. While at the same time, guide the connecting rod into position on crankshaft rod journal.

9. Measure engine connecting rod bearing clearances with the use of Plastigage or equivalent. The following is the recommended procedure for the use of Plastigage:

- 1) Remove the oil film from surface to be checked. Plastigage is soluble in oil.
- 2) Place a piece of Plastigage across the entire width of the journal. Plastigage must not crumble in use. If brittle, obtain fresh stock.

NOTE: DO NOT rotate the crankshaft. Plastigage will smear, causing inaccurate results.

- 3) Assemble using the old rod cap bolts. Torque the old rod cap bolts of the bearing being checked to **40 N·m plus 90° Turn (30 Ft. Lbs. plus 90° Turn)**.

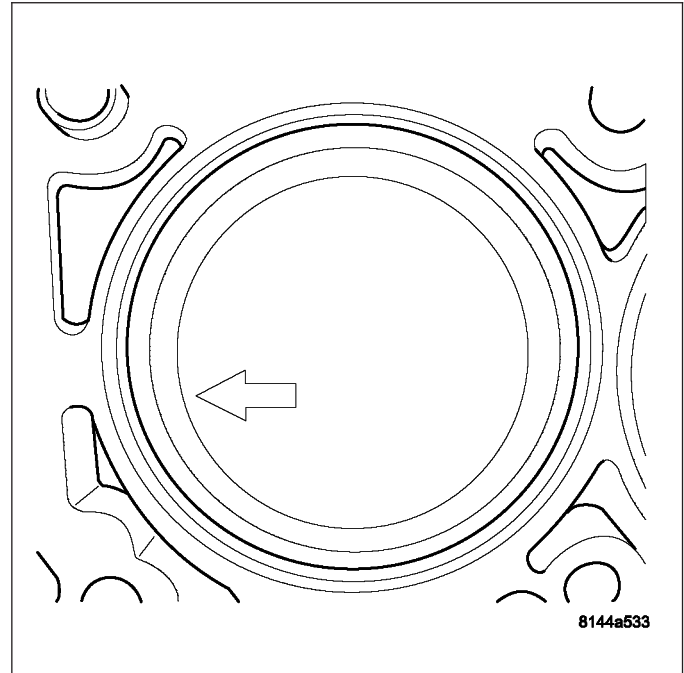

NOTE: Typical connecting rod cap shown.

- 4) Remove the bearing cap and compare the width of the flattened Plastigage (2) with the scale provided on the package (1). Locate the band closest to the same width. This band shows the amount of clearance. Differences in readings between the ends indicate the amount of taper present or the possibility of foreign material trapped under the bearing insert.
- 5) Record all readings taken. Compare clearance measurements to crankshaft specifications table.

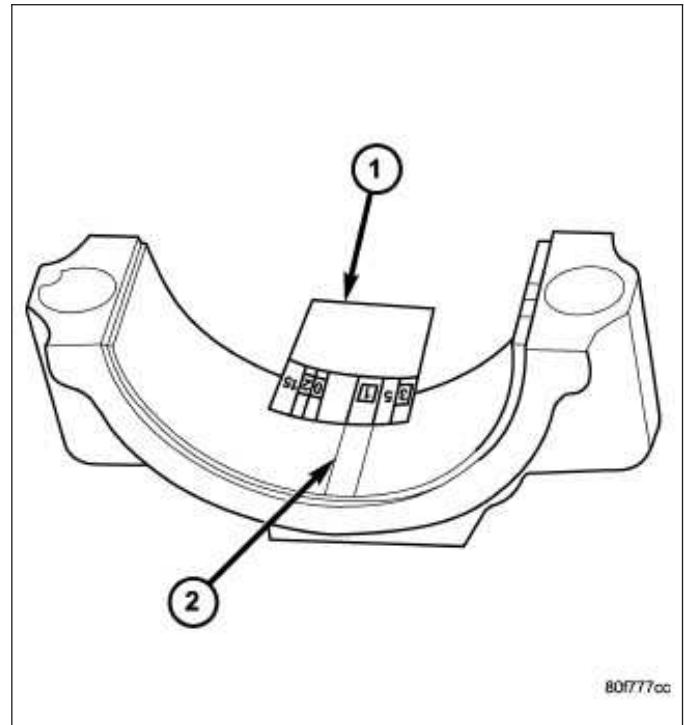

CRANKSHAFT

DESCRIPTION	SPECIFICATION	
	Metric	Standard
Connecting Rod Journal Diameter	53.992-54.008 mm	2.1257-2.1263 in.
Connecting Rod Bearing Clearance	0.016-0.056 mm	0.0006-0.0022 in.
Out of Round (MAX)	0.005 mm	0.0002 in.
Taper (MAX)	0.003 mm	0.0001 in.

NOTE: Typical connecting rod journal shown.

NOTE: Plastigage is available in a variety of clearance ranges. Use the most appropriate range for the specifications you are checking. Plastigage generally is accompanied by two scales. One scale is in inches, the other is a metric scale.

- 6) Install the proper bearings to achieve the specified bearing clearances.
- 7) Repeat the Plastigage measurement to verify your bearing selection prior to final assembly.

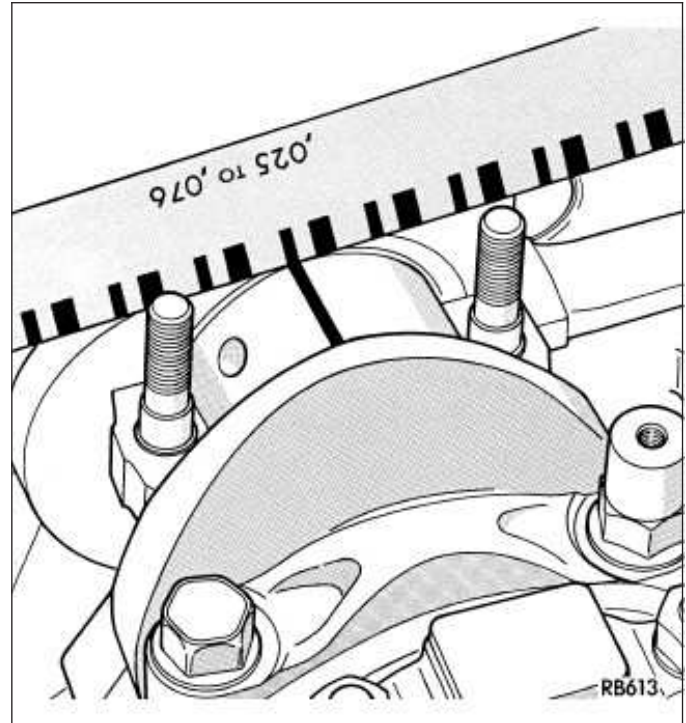

10. Wipe the connecting rod cap (1) clean and lubricate with clean engine oil and install the bearing (3).

NOTE: The connecting rod bearing caps are not interchangeable, line up the previously marked bearing caps and connecting rods to ensure assembly to their original corresponding rod.

11. Lubricate the bearing surfaces with clean engine oil and position the rod cap onto the connecting rod.

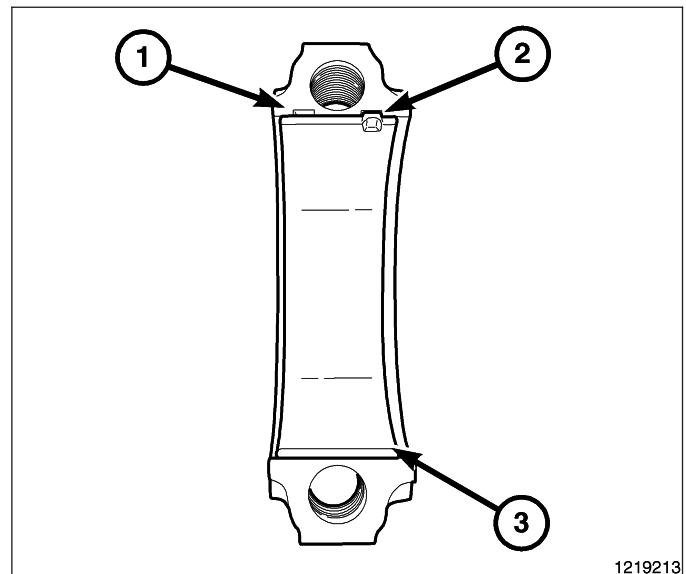

CAUTION!

- When installing the connecting rods, make sure the wide side of the connecting rod faces the crankshaft and the narrow sides face each other.
- Connecting rod bolts are not reusable. Use the new connecting rod bolts included in this kit.

12. Verify the connecting rods are properly installed, the wide side (1) of the connecting rod is facing towards the crankshaft and the narrow sides (2) of the connecting rods face each other.
13. Lubricate the **new** rod cap bolts with clean engine oil, install and torque to **40 N·m plus 90° Turn (30 Ft. Lbs. plus 90° Turn)**.

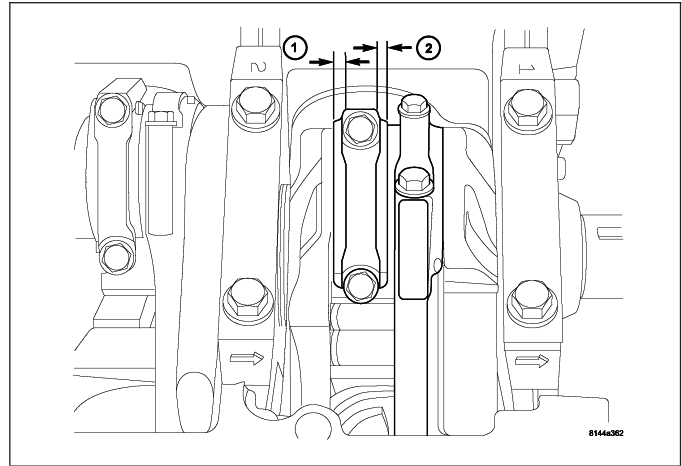

14. Position the piston oil cooler jets (1).
15. Install the piston oil cooler jet retaining bolts (2) and torque to **13 N·m (10 Ft. Lbs.)**.

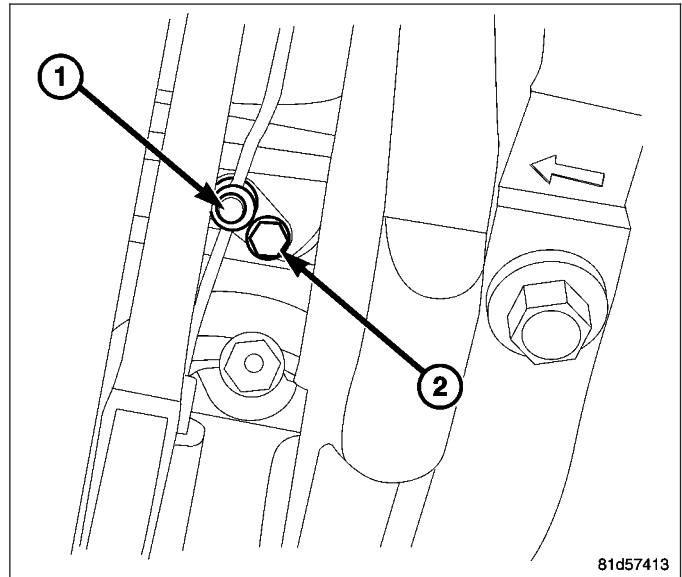

16. Install the oil pump pickup tube and oil pan.
17. Install the cylinder heads.
18. Install engine into vehicle.
19. Fill all related fluids and lubricants to the appropriate levels.
20. Start the engine and check for leaks.