

" For Service Replacement Parts and Technical Support "
call 1-800-322-0522 or (616) 656-6886

GB

INSTALLATION INSTRUCTION

FOLD-A-COVER HARD FOLDING TONNEAU COVER

E

INSTRUCCIONES DE MONTAJE

CUBIERTA DURA PLEGABLE FOLD-A-COVER

F

NOTICE DE MONTAGE

COUVERCLE DE PLATEAU RIGIDE À SECTIONS REPLIABLES
"FOLD-A-COVER "

Subject to alteration without notice
Reservadas modificaciones técnicas
Sous réserve de modifications techniques

Expert Fitment Required
Montaje sólo por el concesionario
Montage par spécialiste nécessaire

K6860755 Rev4

© CHRYSLER, LLC

GB APPLICATION: DODGE RAM (09+)

- The Fold a Cover kit is required for use with this hardware kit.
- Temperature should be no lower than 70°F (21.1°C) when installing.
- Be sure the truck is setting on a level surface.
- Apply a dab of blue thread locker to each fastener before use.
- Record the key number and place in glove box or write it in your owner's manual.
- Refer to the Operation and Care Label located on the underside of the rearmost panel on cover (driver's side).
- Product should NOT be installed if vehicle is equipped with overrail bedliner.
- On trucks WITHOUT an underrail bedliner, to IMPROVE the water management, it may be necessary to add to the front panel sheet metal a layer of "closed cell" foam tape (not included in this kit).

E APLICACIÓN: DODGE RAM (09+)

- Se requiere el juego Fold a Cover para utilizar este juego de piezas.
- La temperatura no debe ser inferior a los 21.1°C (70 °F) durante la instalación.
- Asegúrese de que la camioneta esté en una superficie plana y horizontal.
- Aplique una pizca de sellador de rosca a cada fijador antes de ponerlo en uso.
- Registre el número de la llave y colóquelo en la guantera o escríbalo en su Manual del propietario.
- Consulte el rótulo de Operación y cuidados ubicado en el lado de abajo del panel extremo posterior de la cubierta (del lado del conductor).
- Este producto no debe ser instalado si el vehículo está equipado con una camisa de caja del tipo que cubre los largueros.

F APPLICATION : DODGE RAM (09+)

- L'ensemble " Fold-a-cover " doit être utilisé avec cette trousse de matériel.
- Lors de l'installation, la température ne doit pas être inférieure à 21.1°C (70°F).
- Assurez-vous que votre camion se trouve sur une surface plane.
- Enduisez chaque élément de fixation de colle frein avant l'utilisation.
- Notez le numéro de code et laissez-le dans la boîte à gants ou inscrivez-le dans votre manuel du propriétaire.
- Consultez l'étiquette Fonctionnement et entretien (Operation and Care) située sur la face antérieure du panneau arrière, sur le couvercle (côté conducteur).
- Le produit ne doit pas être installé si le véhicule est équipé d'une doublure de caisse montée sur le longeron.

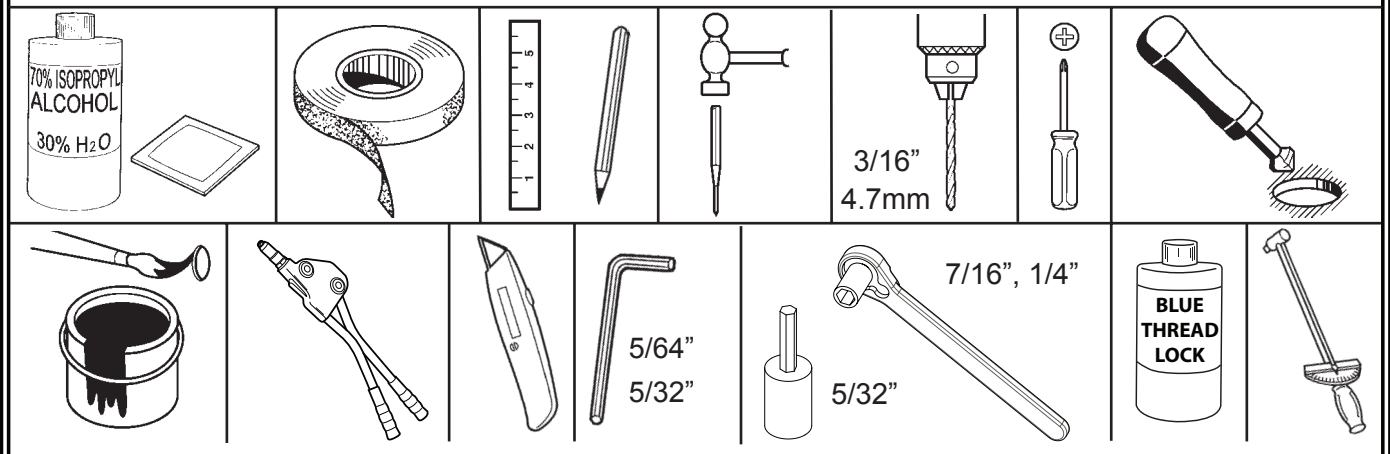

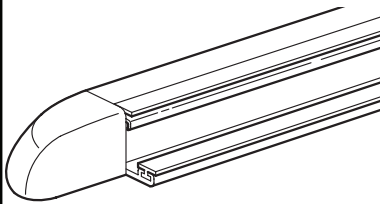

Rails shipped separately for
6'4"(1.9m) & 8'(2.4m) beds.
Rails sont livrés séparément pour
1.9m & 2.4m lits.
Rieles se envían por separado de
1.9m & 2.4m camas.

A 1x

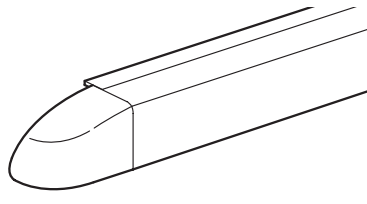

Rails shipped separately for
6'4"(1.9m) & 8'(2.4m) beds.
Rails sont livrés séparément pour
1.9m & 2.4m lits.
Rieles se envían por separado de
1.9m & 2.4m camas.

B 1x

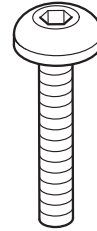

C 4x/6x

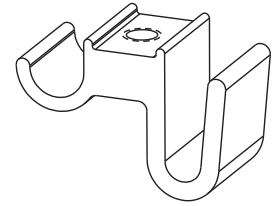

D 4x/6x

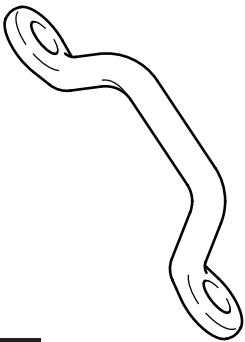

E 1x

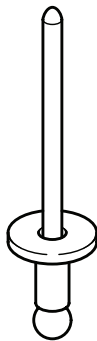

F 2x

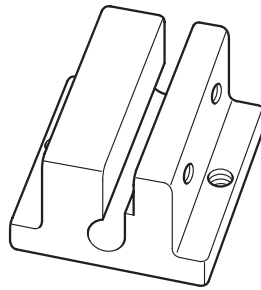

G 2x



H 2x

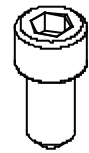

I 4x

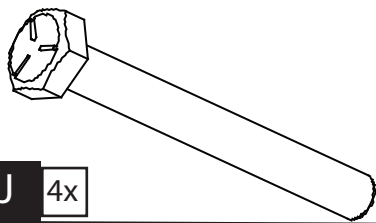

J 4x

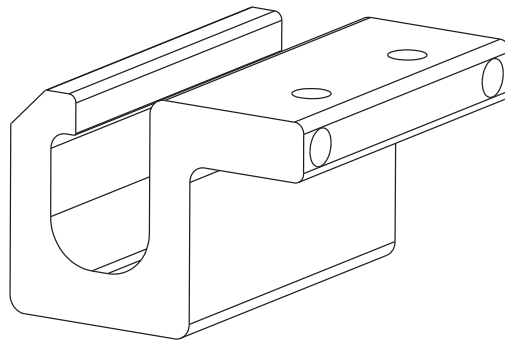

L 2x

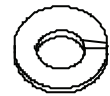

M 4x



K 4x

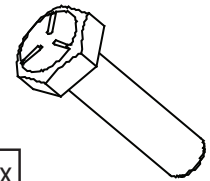

N 4x

?---For Service Replacement Parts and Technical Support call 1-800-322-0522 or (616) 656-6886--- ?

Para refacciones o soporte técnico llame a 1-800-322-0522 o (616) 656-6886 -- ES

Pour les pièces ou le support technique d'appel 1-800-322-0522 ou (616) 656-6886 -- FR

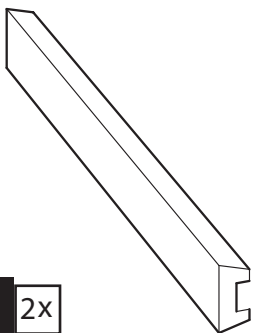

O 2x

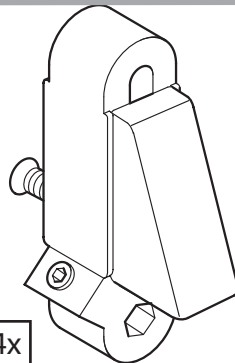

P 4x



Q 1x



R 1x

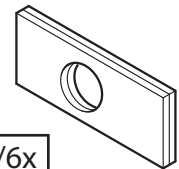

S 4x/6x

Molded Bedrail Cover Supplement

Do This First!

On some applications the Molded Bedrail Cover needs to be modified to access the Front Stake Pocket Opening. Using the detail molded into the cover (shown below), scribe lines as dimensioned below. The final opening size will be 35mm X 50mm..... using a utility knife, carefully cut out the dashed line and remove that material section.

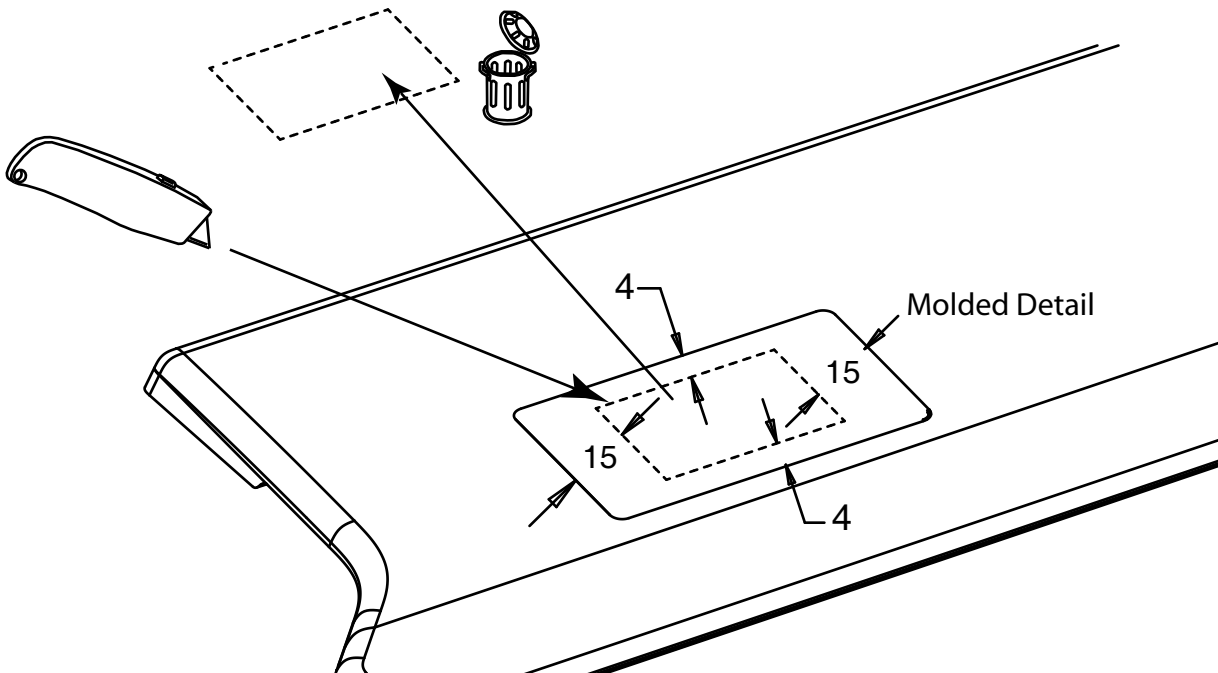

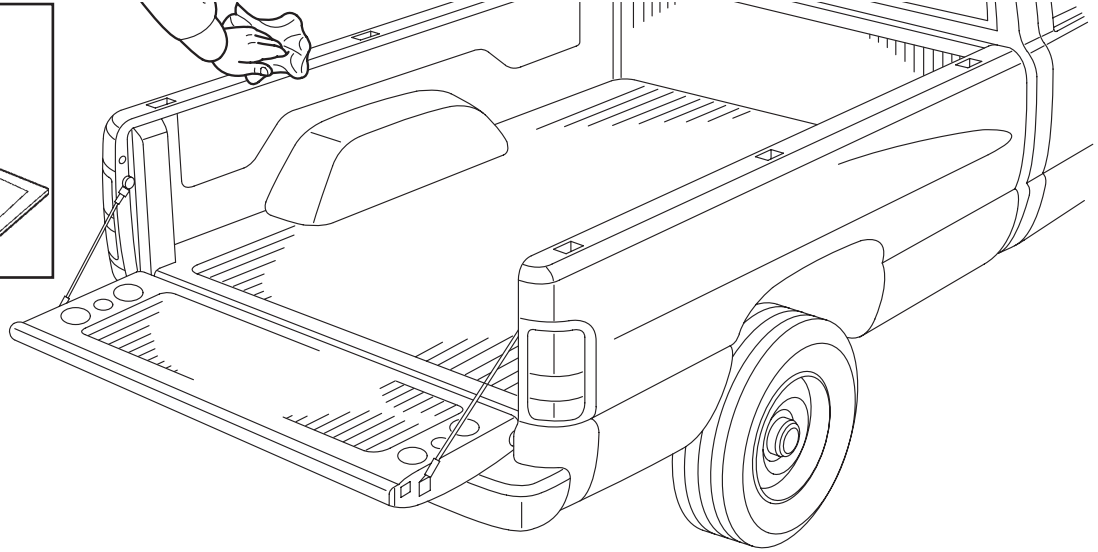

1

REMOVE PAPER LINING FROM FOAM TAPE
 RETIRE LA GUARNICIÓN PAPEL DE CINTA DE ESPUMA
 RETIRER DOUBLURE DE PAPIER DE RUBAN MOUSSE

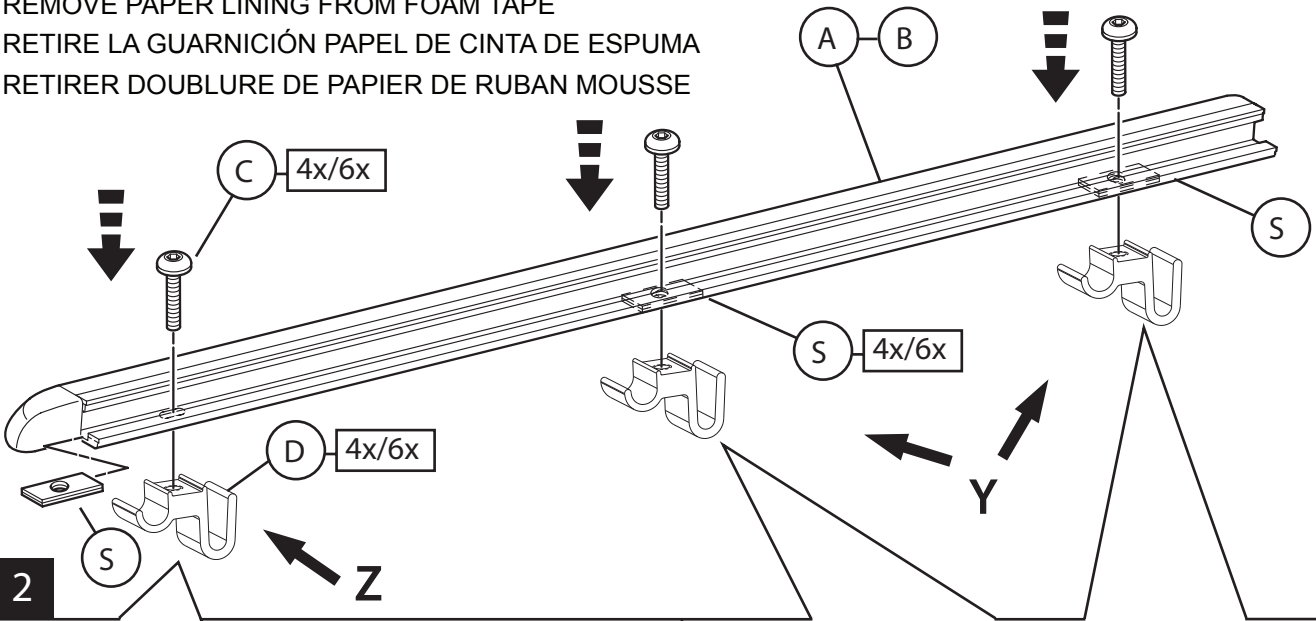

2

REAR STAKE POCKET

DO NOT FULLY TIGHTEN.
 NO CEÑIR COMPLETAMENTE.
 NE SERREZ PAS LES VIS TOTALEMENT.

FRONT/CENTER STAKE POCKET

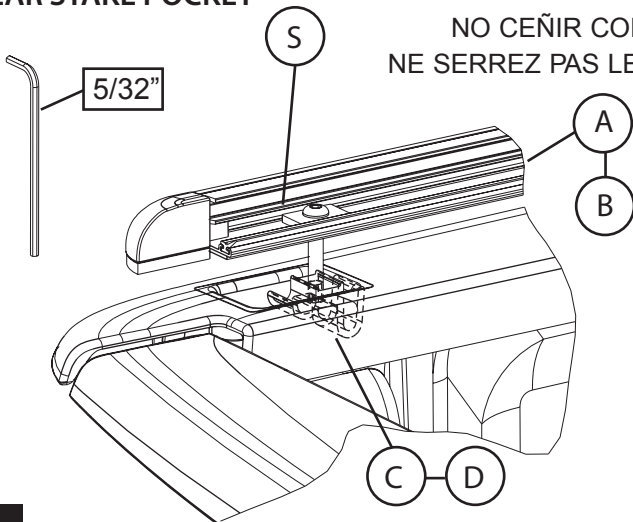

3

LOCATION Z

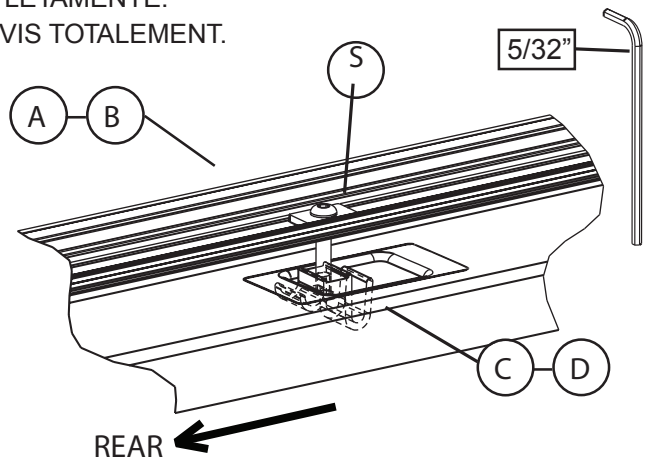

4

LOCATION(S) Y

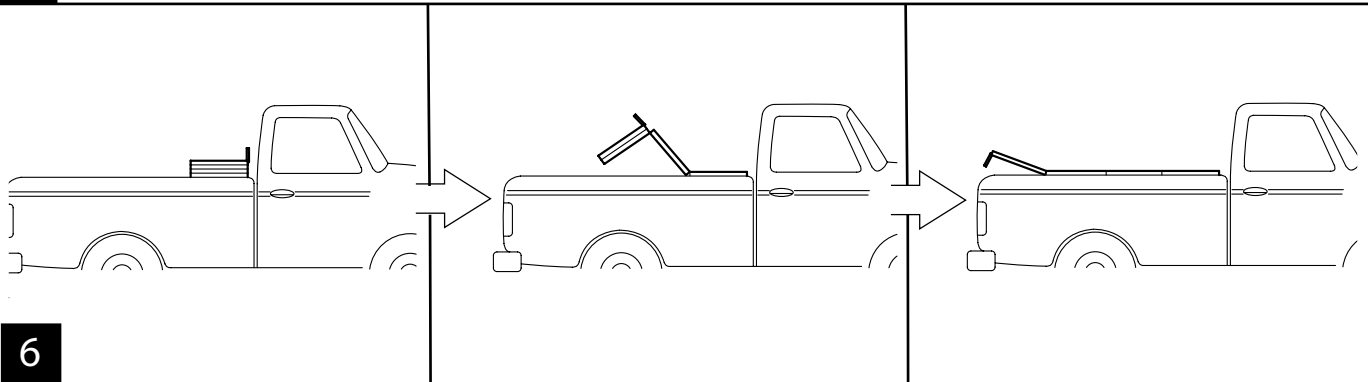
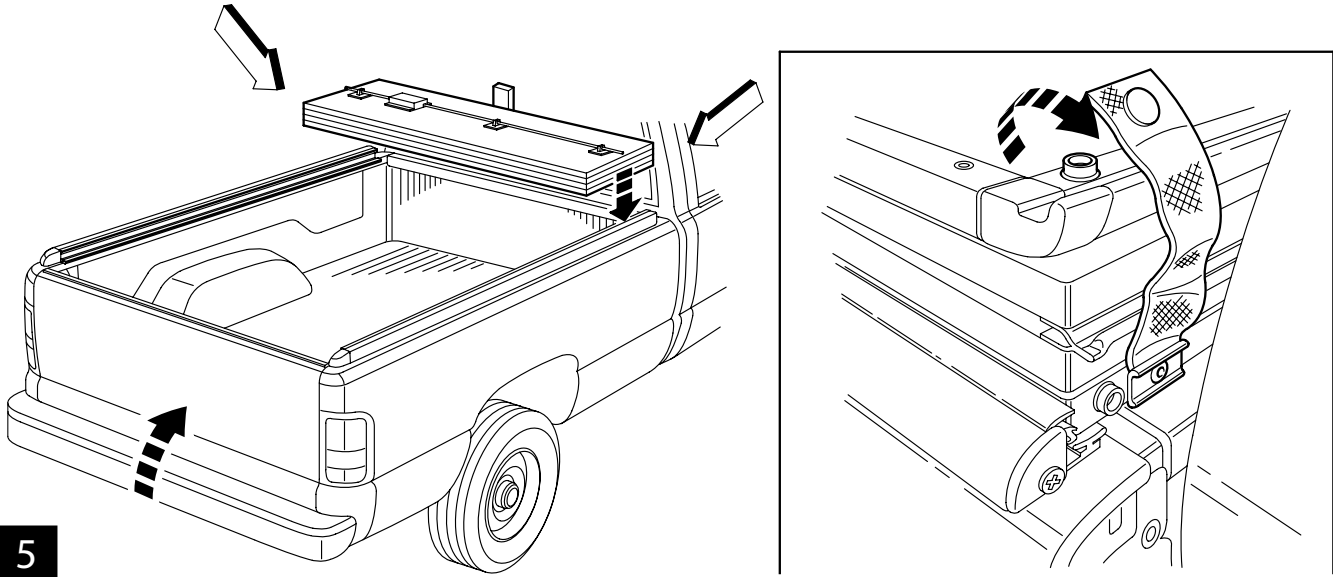

CENTER THE COVER AND SIDE RAILS EVENLY ONTO THE TRUCK BOX.

DIM "A" = DIM "B"

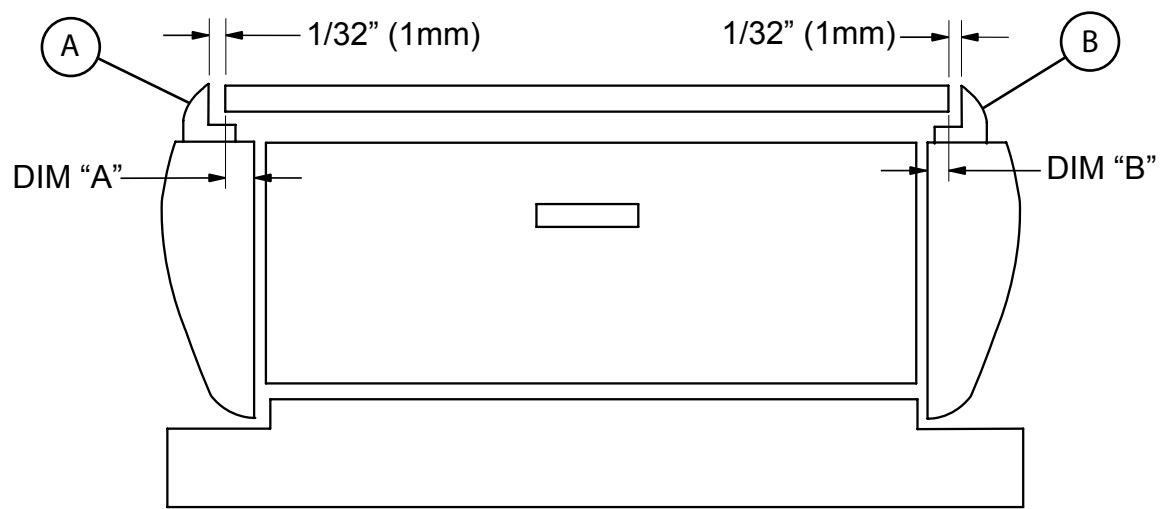

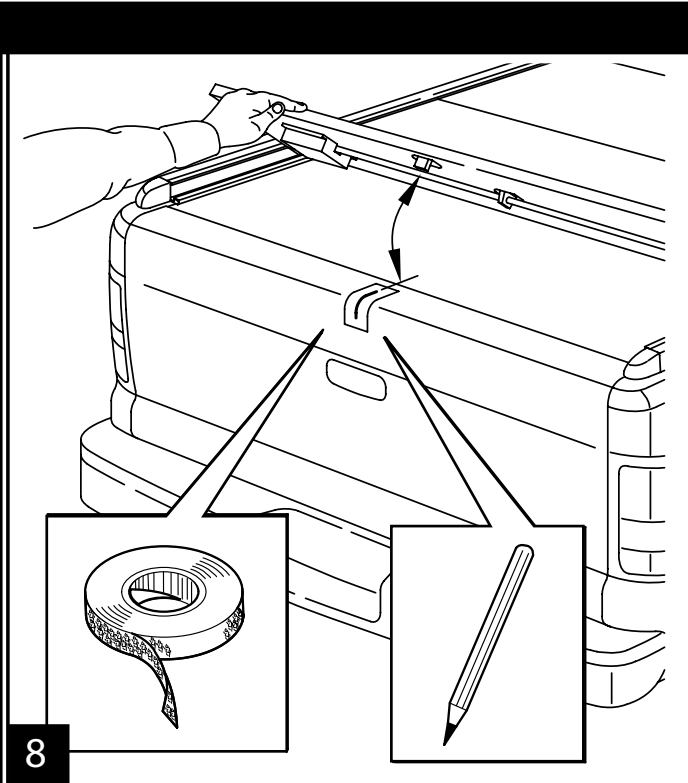

8

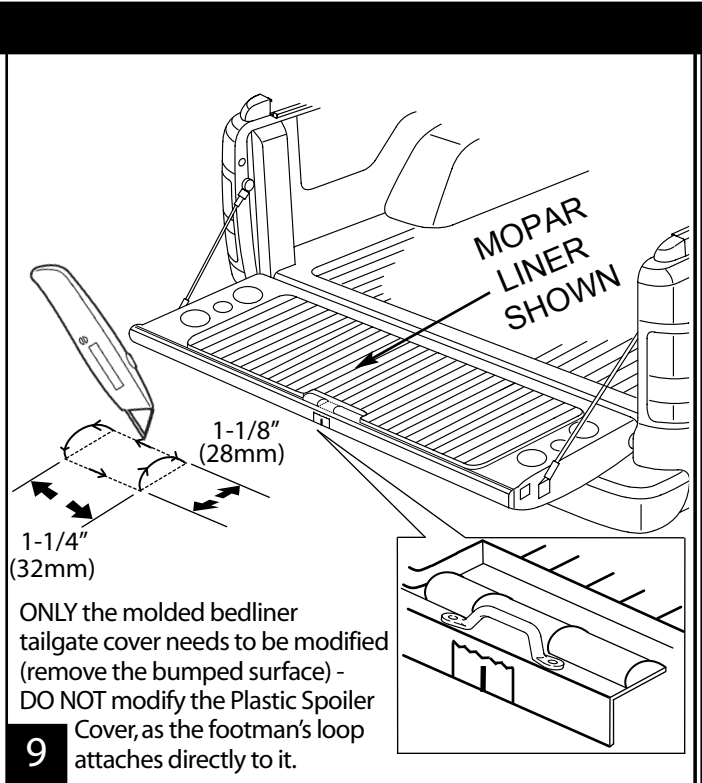

9

ONLY the molded bedliner tailgate cover needs to be modified (remove the bumped surface) - DO NOT modify the Plastic Spoiler Cover, as the footman's loop attaches directly to it.

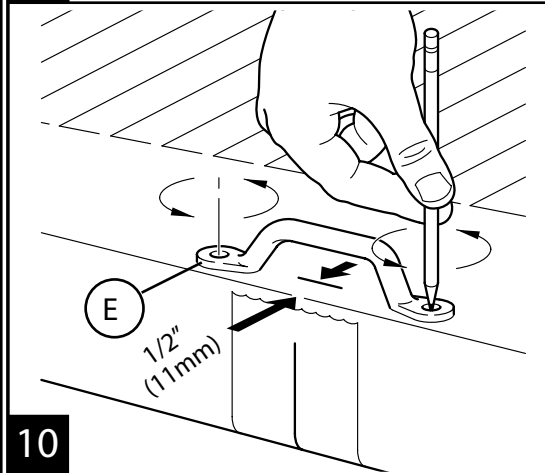

10

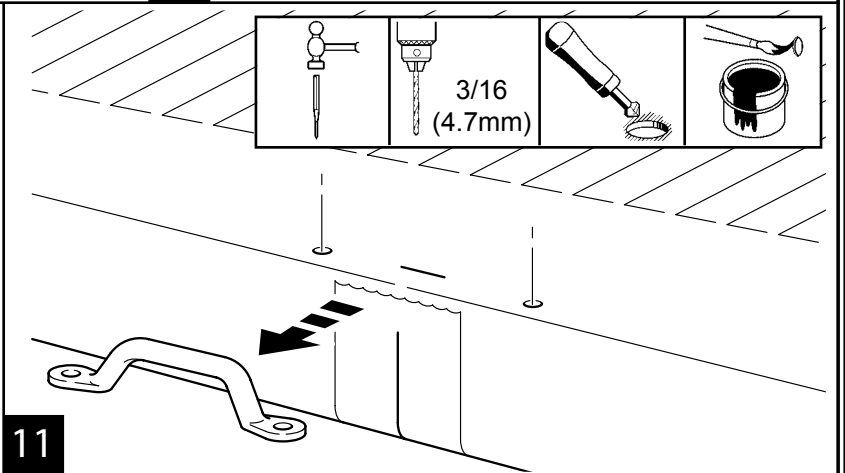

11

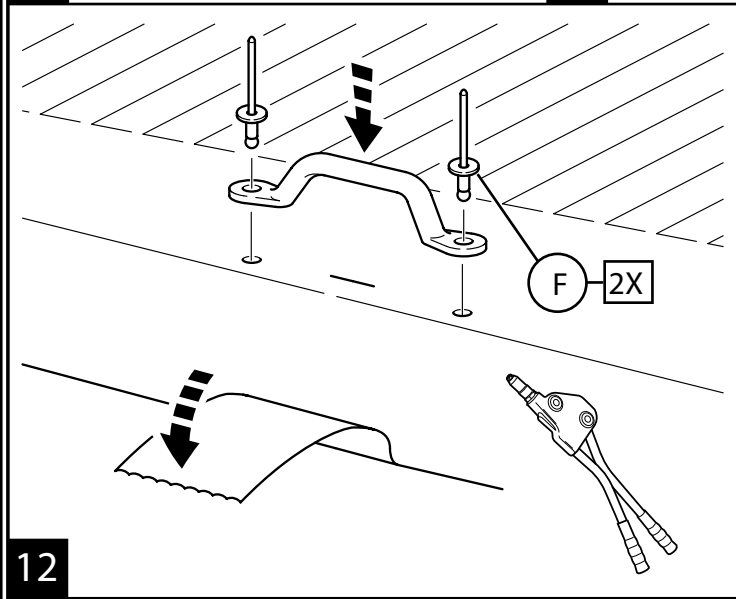

12

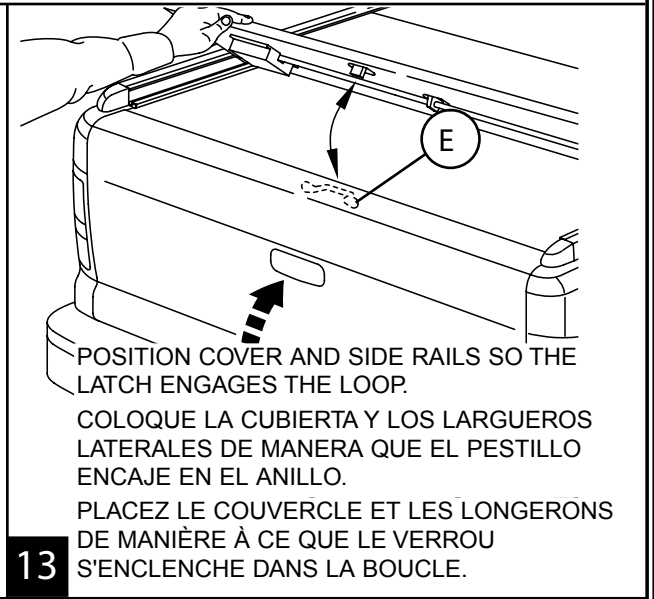

13

POSITION COVER AND SIDE RAILS SO THE LATCH ENGAGES THE LOOP.

COLOQUE LA CUBIERTA Y LOS LARGUEROS LATERALES DE MANERA QUE EL PESTILLO ENCAJE EN EL ANILLO.

PLACEZ LE COUVERCLE ET LES LONGERONS DE MANIÈRE À CE QUE LE VERROU S'ENCLENCHE DANS LA BOUCLE.

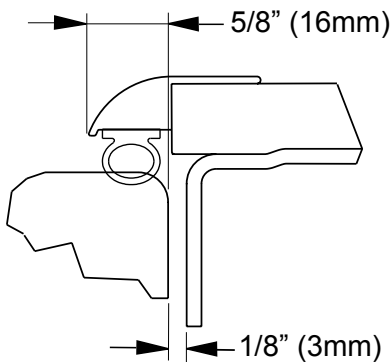
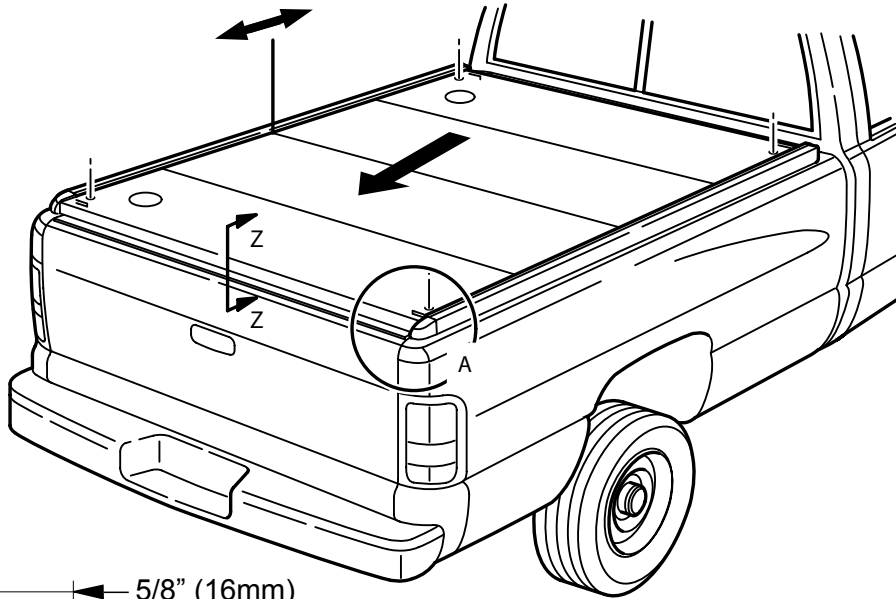

SEC. Z-Z
PROPER FIT
ENCAJE CORRECTO
INSTALLATION CORRECTE

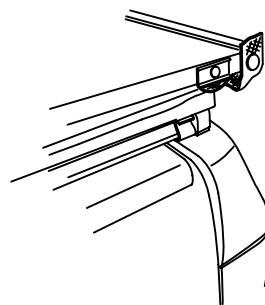

PROPER FIT
ENCAJE CORRECTO
INSTALLATION CORRECTE

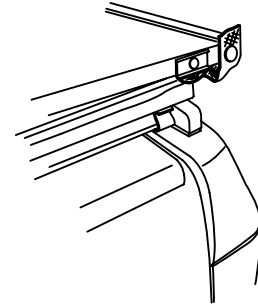

INCORRECT FIT
ENCAJE INCORRECTO
INSTALLATION INCORRECTE

VIEW -A-

14

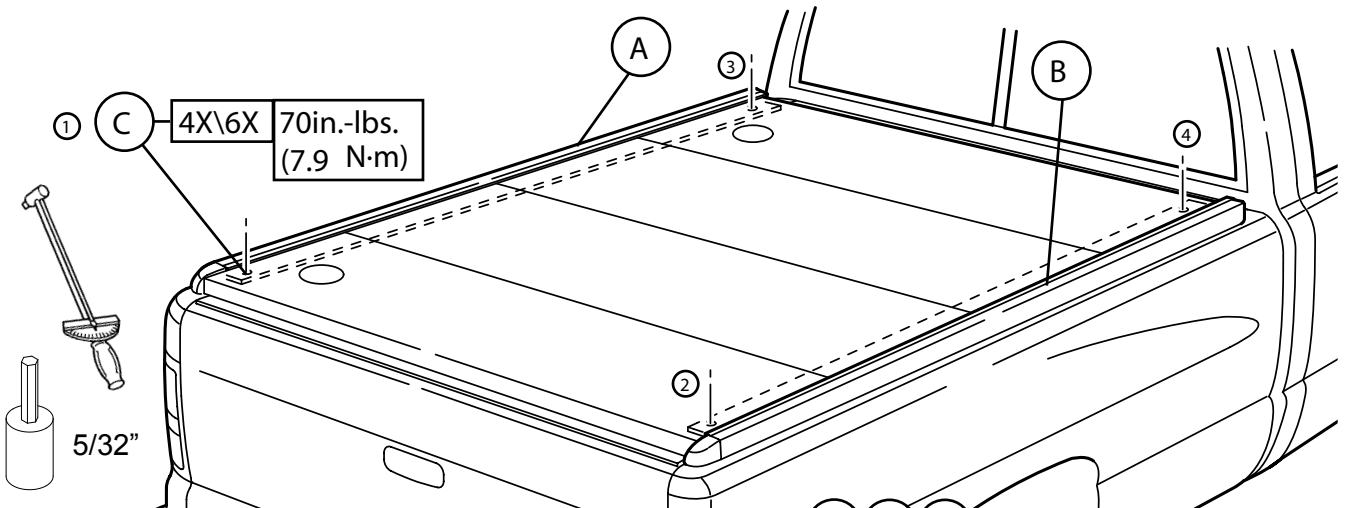

OPEN THE REAR AND FRONT PANELS TO TIGHTEN SCREWS. (C) (D) (S)
 ABRA LOS PANELES TRASEROS Y DELANTEROS PARA CEÑIR LOS TORNILLOS. (C) (D) (S)
 OUVREZ LES PANNEAUX ARRIÈRE ET AVANT POUR SERRER LES VIS. (C) (D) (S)

15

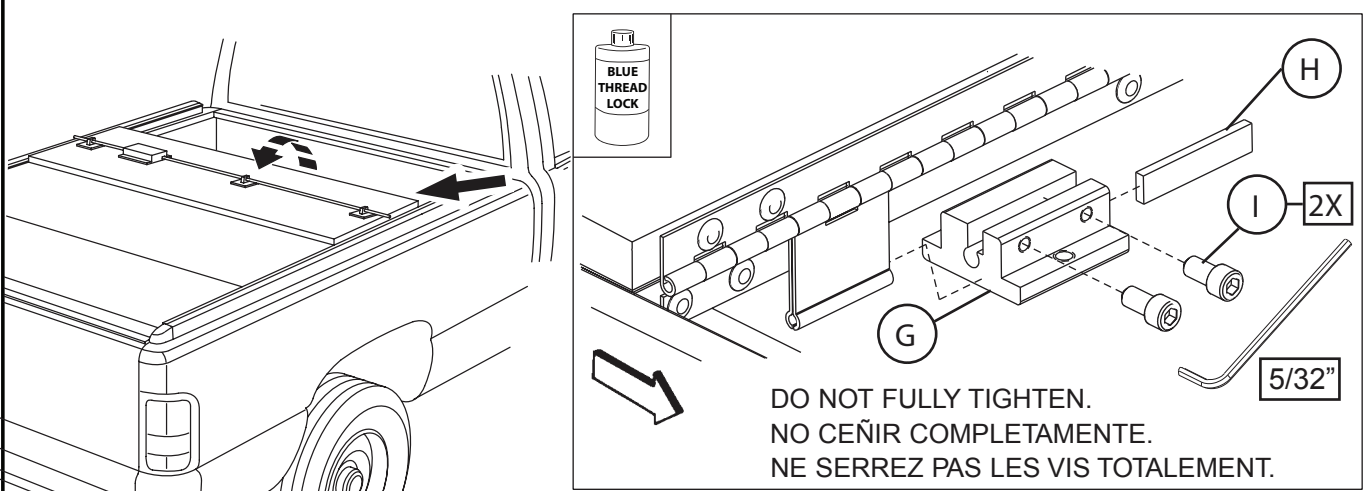

16

PART H MUST BE FULLY SEATED TO AVOID BINDING AT THE HINGE
PARTE H DEBE ESTAR COMPLETAMENTE ASENTADO PARA EVITAR LA UNIÓN EN LA ARTICULACIÓN
PARTIE H DOIT ÊTRE BIEN EN PLACE POUR ÉVITER LA LIAISON À LA CHARNIÈRE

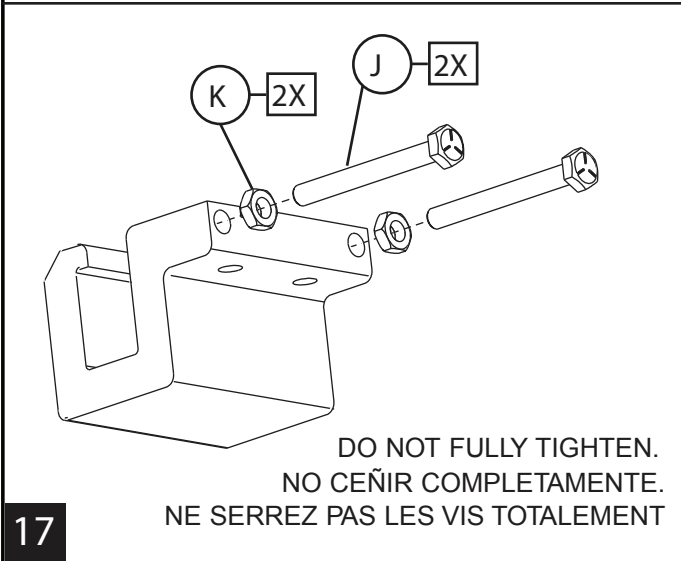

17

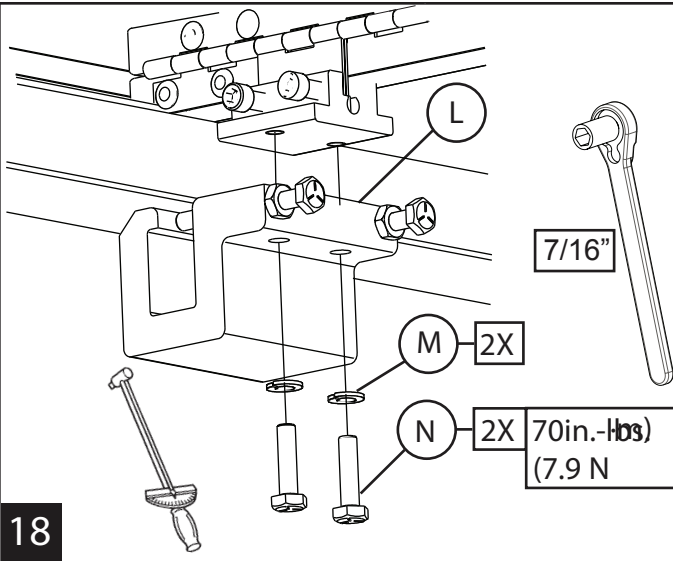

18

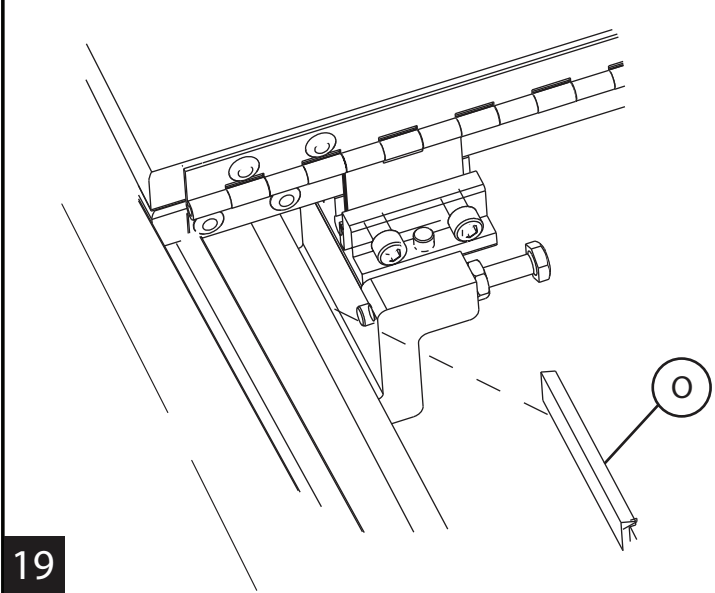

19

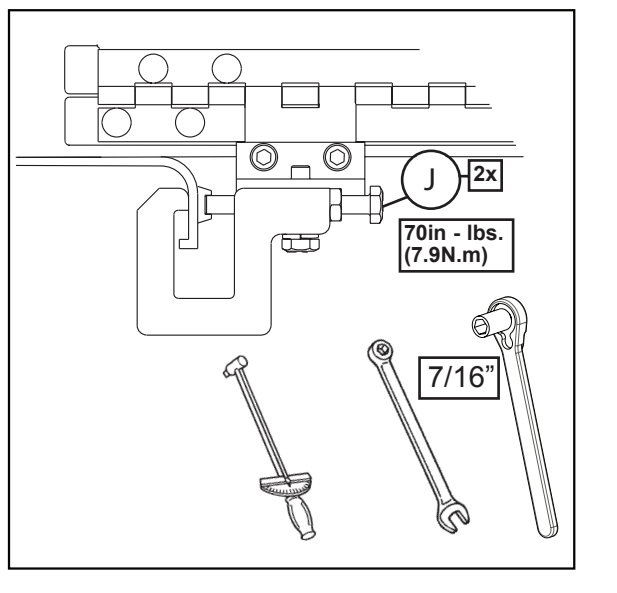

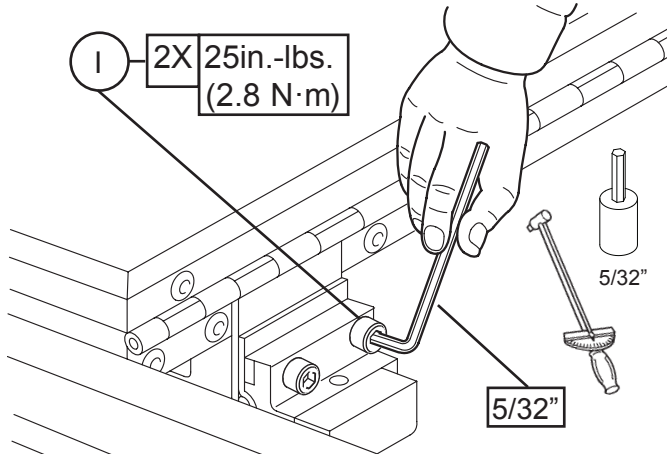

REPEAT 16 - 20 FOR OTHER SIDE.
REPITA LOS PASOS 16 A 20 EN EL OTRO LADO.
RÉPÉTEZ LES ÉTAPES 16 À 20 POUR L'AUTRE CÔTÉ.

20

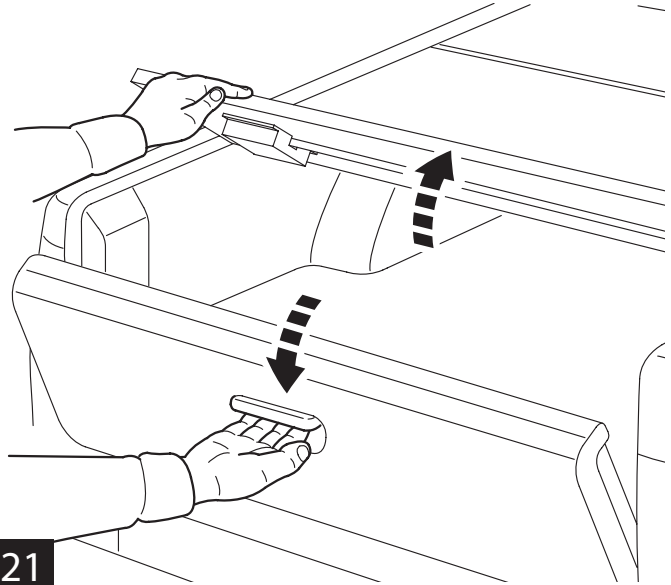

21

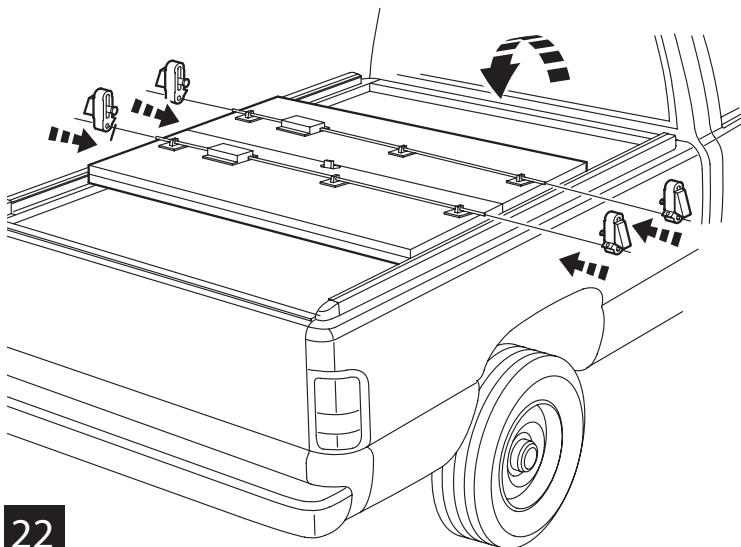

22

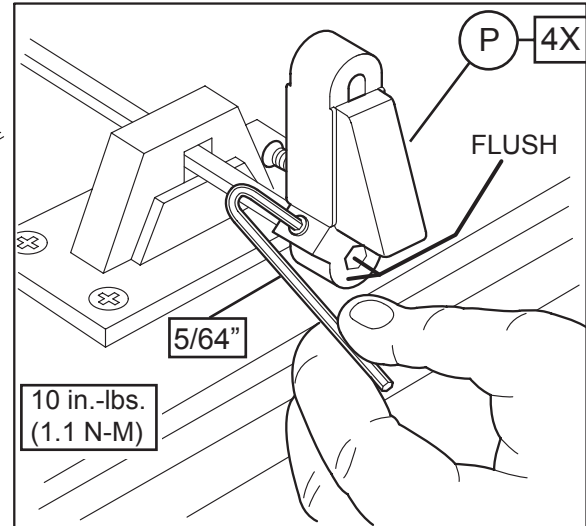

SOME TRIMMING OF BEDLINER MAY BE REQUIRED
RECORTE DE ALGUNAS BEDLINER PUEDE SER REQUERIDO
QUELQUES RECADERER DE BEDLINER PEUT ETRE NECESSAIRE

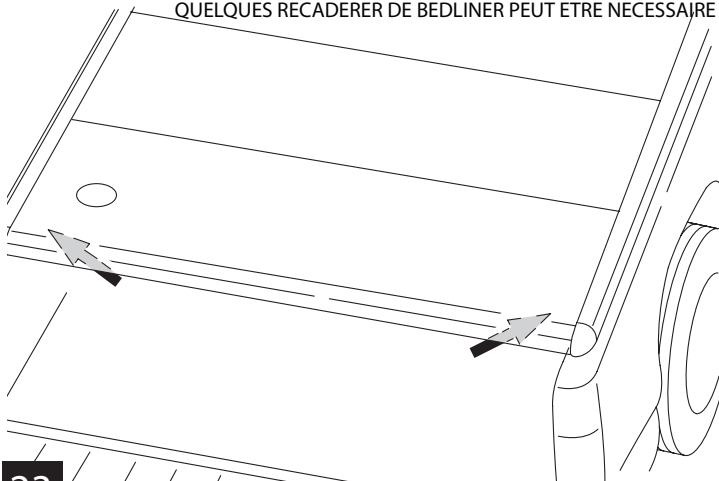

23

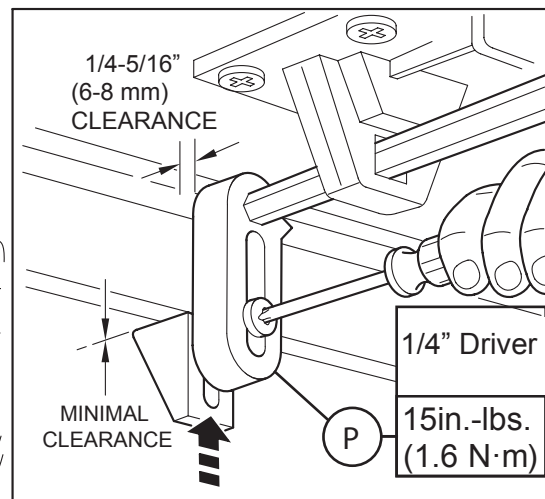

TYP ALL LOCATIONS

THIS STEP NOT REQUIRED TYPICALLY

Este paso no es requerido tipicamente -- ES
 Cette étape est généralement pas nécessaire -- FR

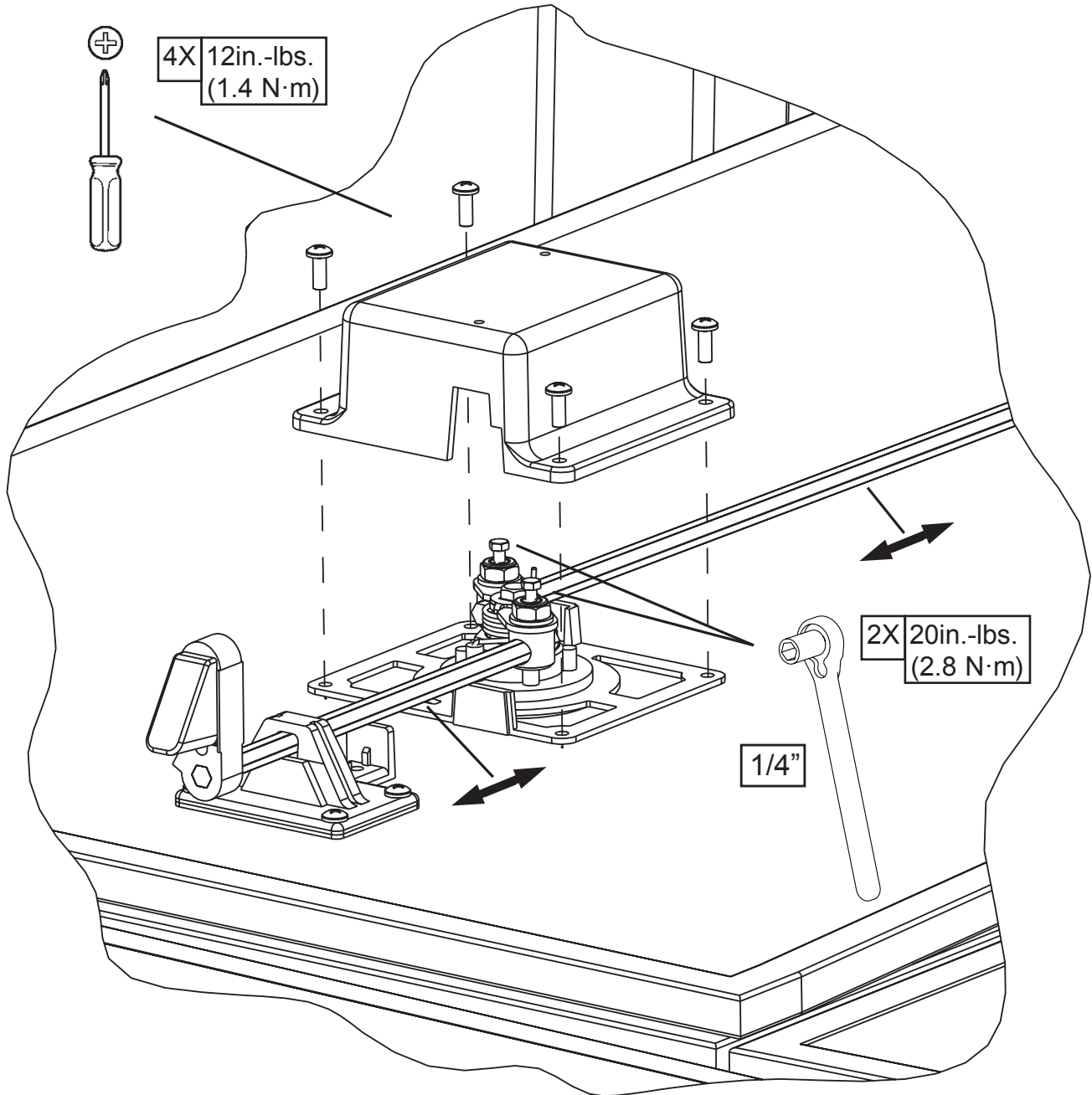

ADJUST DRIVER & PASSENGER ROD LOCATION AS NEEDED ON FRONT & REAR PANEL

Ajuste la ubicación de la vara del panel trasero y delantero del lado del pasajero y del conductor como sea necesario -- ES
 Ajustez l'emplacement de la tige sur le panneau arrière et avant le côté passager et le conducteur, au besoin -- FR

NO TONNEAU IS 100% WATERPROOF - This tonneau has been rigorously tested under various types of car wash systems with minimal water entry.

On trucks without Bedliners, to improve water management on the front body panel, you can ADD a layer of "closed cell" foam (not included in kit), used typically for pickup cap installations.

With Bedliner

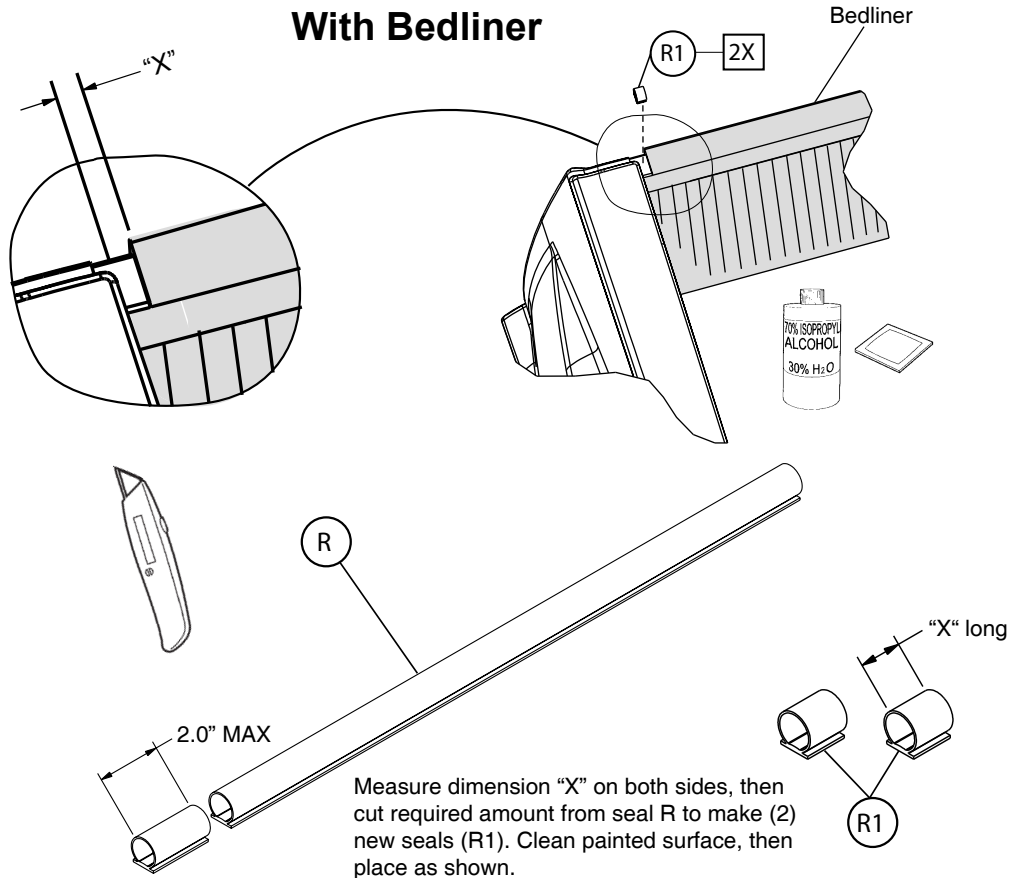

25

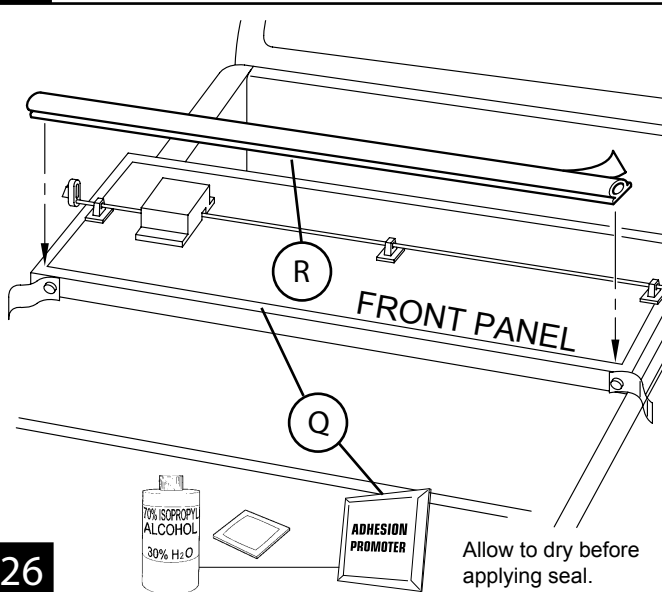

26

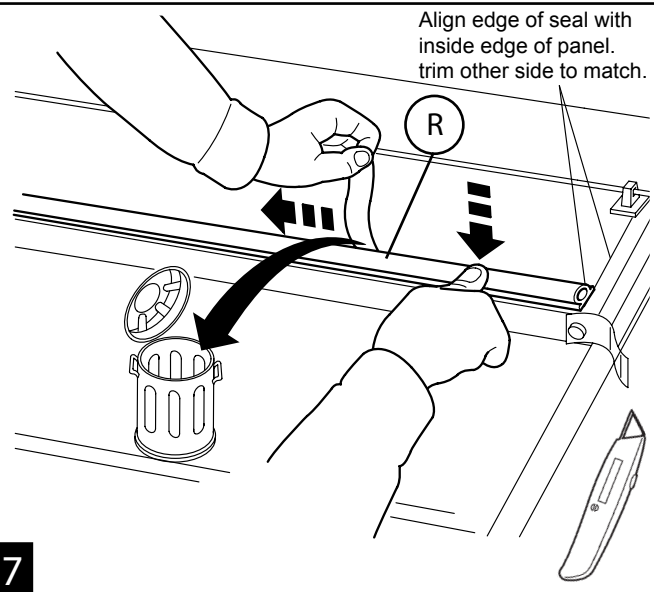

27